

RideLite 200

Lightweight Trailer Suspension

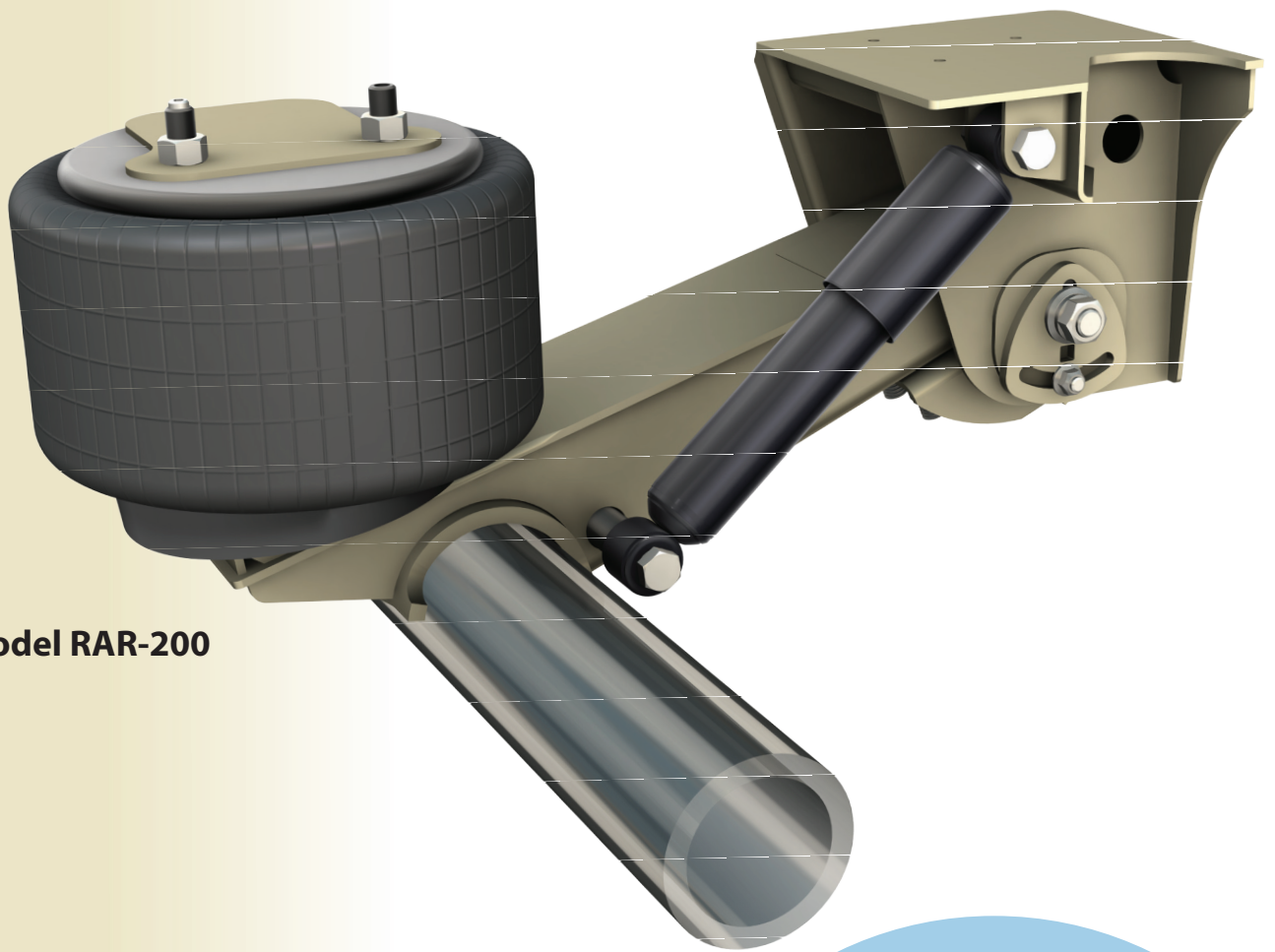

Model RAR-200

Full-featured suspension for all general applications where weight is important

Weld-on or bolt-on mounting available

Non-captured axle

11" - 25" mounting heights

25,000 & 30,000 lb. capacities



www.ridewellcorp.com ♦ 800.641.4122 ♦ Fax 417.833.4560

RideLite 200

Lightweight Trailer Suspension

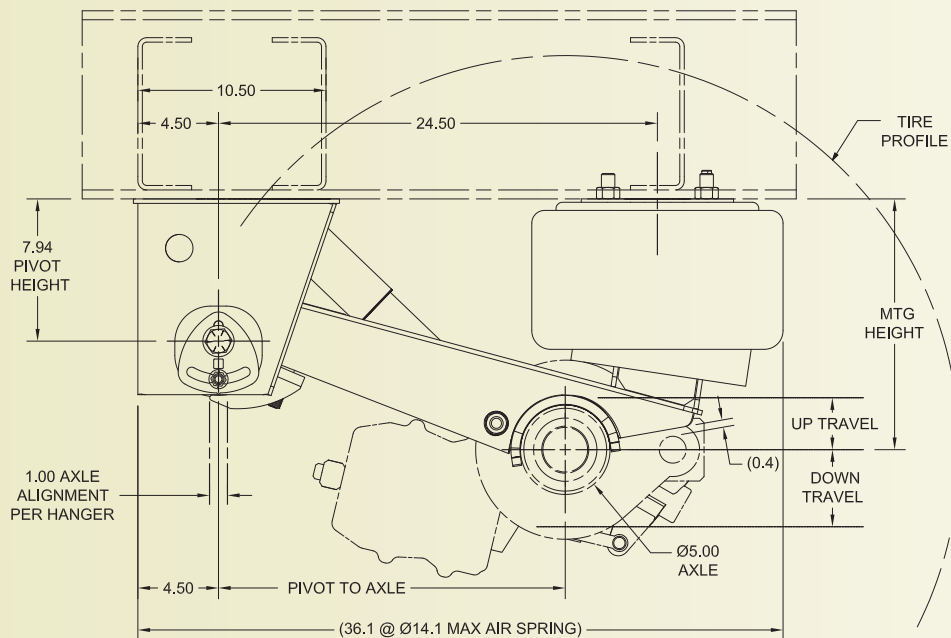

14 INCH MOUNTING HEIGHT SHOWN

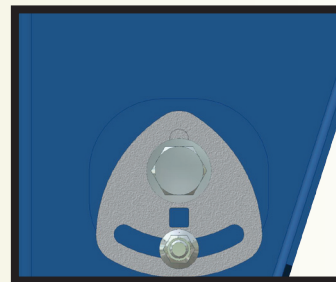

Ridewell's Speet Set™ makes manual alignment easier than ever (+/- 1/2" at hanger).

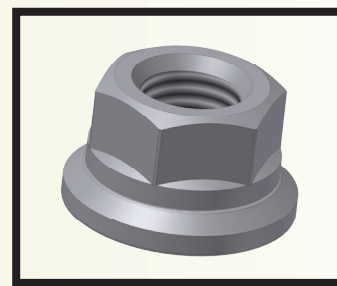

The Securelok™ pivot nut helps to maintain pivot clamping force. This unitized nut, washer, and shim is highly resistant to loosening under vibration.

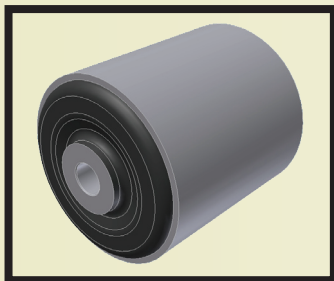

Longwearing double-bonded pivot bushing can be installed or replaced with common shop tools. No hydraulic press required.

Patented coutoured axle seat optimizes axle weldment by decreasing stress concentrations. No u-bolts required.

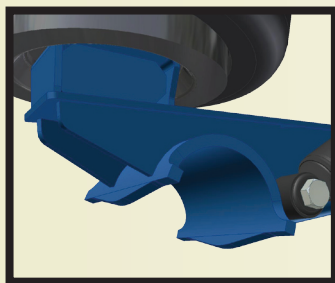

Features:

- 25,000 & 30,000 lb. capacity
- Non-captured axle
- Integrated shock absorber mounting
- Axle alignment adjustment capability +/- .50" at hanger
- Mounting heights from 11" to 25"
- Lift kit available
- Integrated height control valve kit available
- Available with factory-integrated Ridewell axle



P.O. Box 4586 ♦ Springfield, Missouri 65808
www.ridewellcorp.com ♦ 800.641.4122 ♦ Fax 417.833.4560