

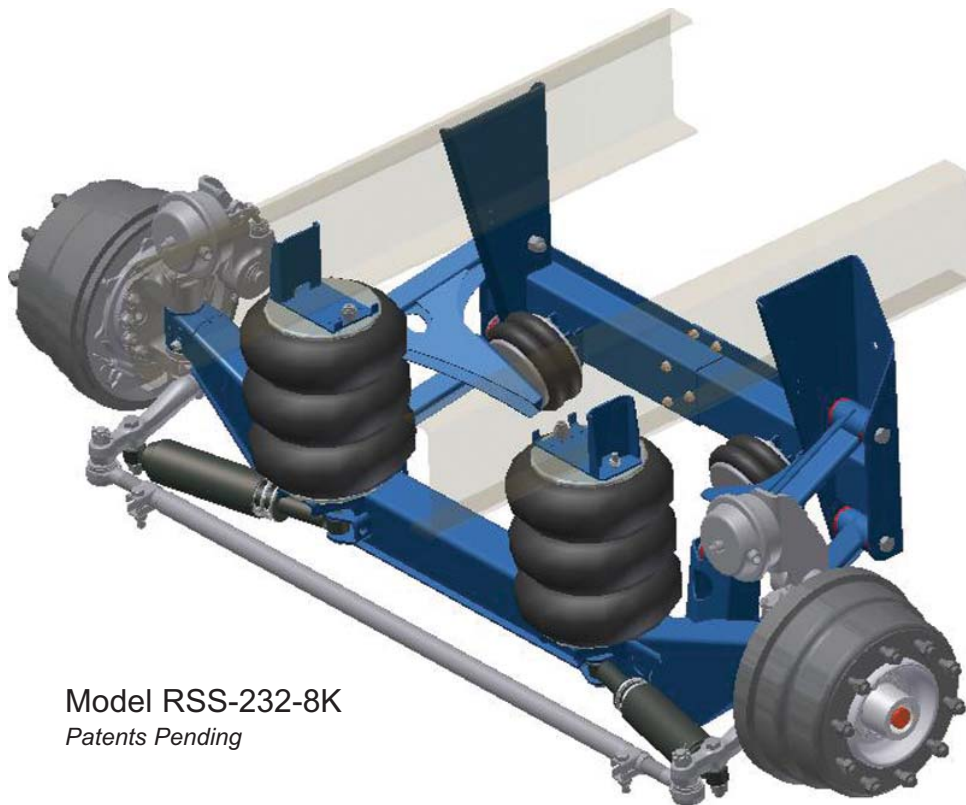

**RIDEWELL
SUSPENSIONS**

Introducing Ridewell's New Self-Steering Auxiliary Axle Suspension System in an 8,000 lb. capacity



Model RSS-232-8K
Patents Pending

Ridewell 8K Flex-Trac™

The ultimate in flexibility and lightweight!

**All the features of our 232 suspension
in an 8,000 pound capacity.**

Features:

- 8,000 lb. capacity
- 690 pounds
- 13 1/2" total travel
- 10" up travel
- Flexible system easily adjusts to various frame widths and ride heights
- All steel construction
- Compact 21.7" mounting envelope
- Urethane bushings for long life
- 28 degree wheel cut
- Factory pre-plumbing available

Model RSS-232 Self-Steering Auxiliary Axle Suspension System - 8,000 lb. cap.

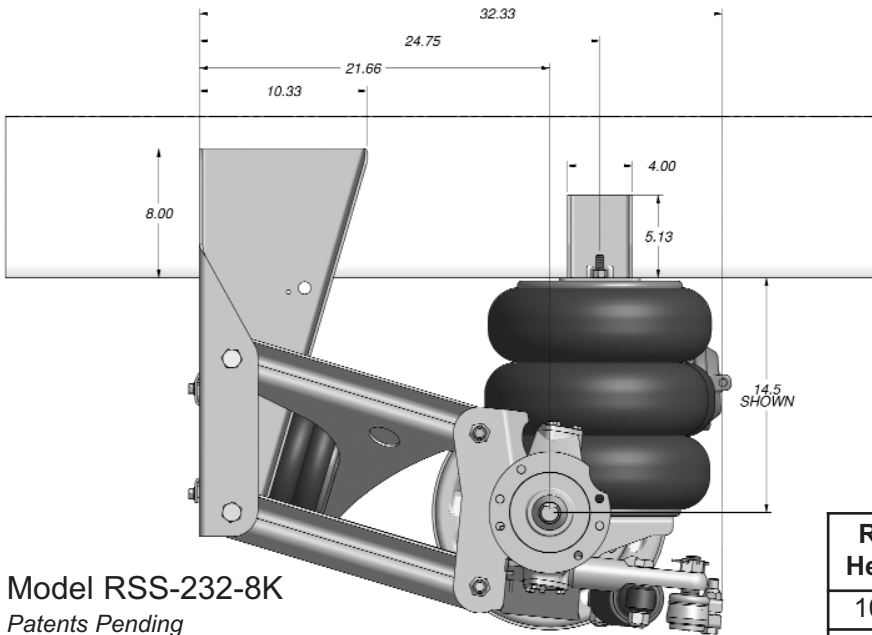

Great for any auxiliary axle application including construction, refuse, and highway.

Travel Table

Ride Height	No Spacer		1" Spacer		2" Spacer	
	Up	Down	Up	Down	Up	Down
10.50	6.0	7.5	--	--	--	--
11.00	6.5	7.0	--	--	--	--
11.50	7.0	6.5	6.0	7.5	--	--
12.00	7.5	6.0	6.5	7.0	--	--
12.50	8.0	5.5	7.0	6.5	6.0	7.5
13.00	8.5	5.0	7.5	6.0	6.5	7.0
13.50	9.0	4.5	8.0	5.5	7.0	6.5
14.00	9.5	4.0	8.5	5.0	7.5	6.0
14.50	10.0	3.5	9.0	4.5	8.0	5.5
15.00	--	--	9.5	4.0	8.5	5.0
15.50	--	--	10.0	3.5	9.0	4.5
16.00	--	--	--	--	9.5	4.0
16.50	--	--	--	--	10.0	3.5

Ridewell's Flex-Trac™ in 8,000 lb. capacity is the perfect suspension for when you need to add just a bit more capacity or you are setting up a multiple axle truck to take maximum advantage of weight laws. Count on Ridewell to save you time, money and headaches.

When developing the 232 Flex-Trac™ series of suspensions Ridewell engineers started with a blank computer screen and the objective of developing the best possible combination of weight reduction and durability in a self-steering lift axle suspension. Their success continues with the development of the 232-8K, an all-steel suspension weighing in at less than 700 pounds, complete with hubs and drums.

The unique Flex-Trac™ system is ideal for the aftermarket installer with built-in flexibility for a range of ride heights and frame widths.



**RIDEWELL
SUSPENSIONS**

Ridewell Corporation
P.O. Box 4586
Springfield, MO 65808-4586
800-641-4122 ♦ (417) 833-4565
Fax (417) 833-4560
www.ridewellcorp.com