

Monopivot 243

Lightweight Trailer Suspension

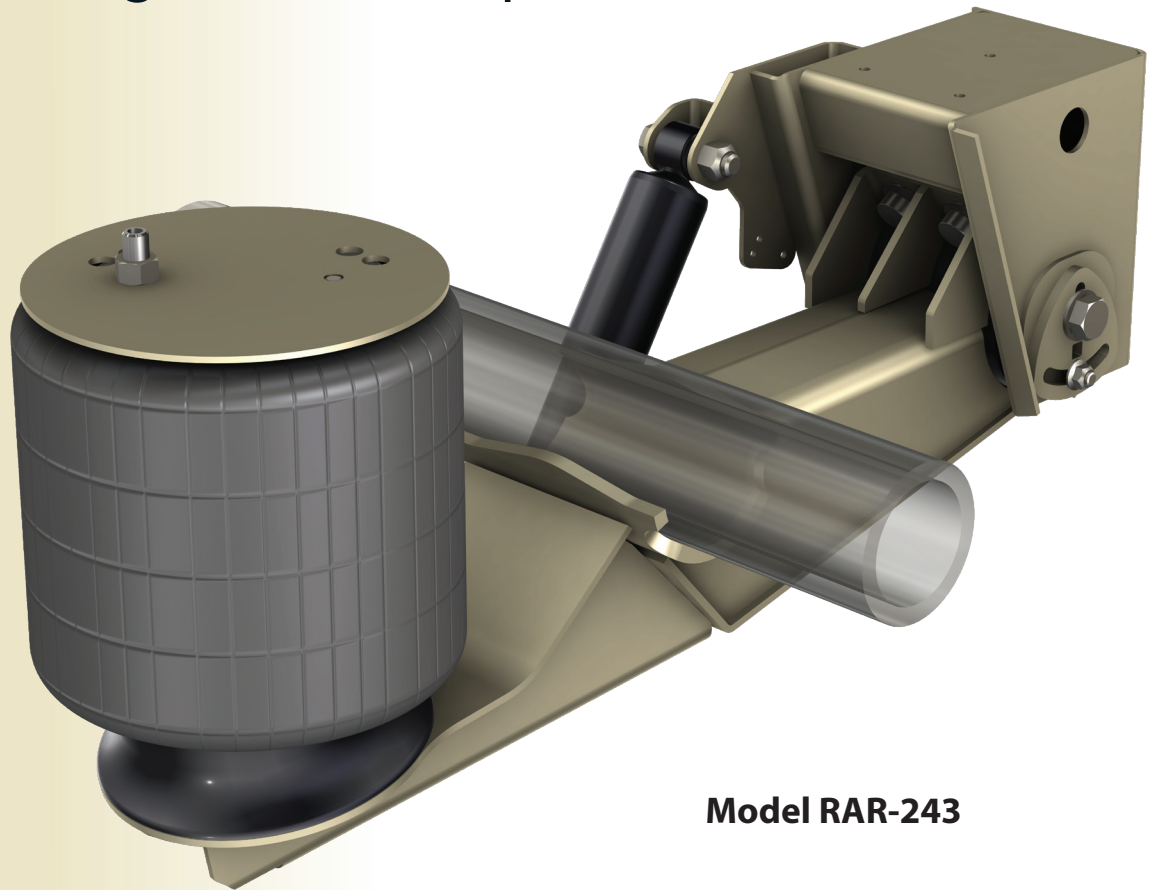

Model RAR-243

*Compatible with air control kits, lift kits,
air springs, shocks, and wear components
of the Monopivot 240*

*Available in ride heights as low as 5 ½",
the ideal suspension beam angle to
minimize wheel hop with 17 ½" tires*

Non-captured axle

25,000 lb. capacity



www.ridewellcorp.com ♦ 800.641.4122 ♦ Fax 417.833.4560

Monopivot 243

Lightweight Trailer Air Ride Suspension



Tapered rubber bushing is designed for maximum durability and reduces stress on the trailing arm and axle. Double-bonded pivot bushing can be installed or replaced with common shop tools. No hydraulic press required.

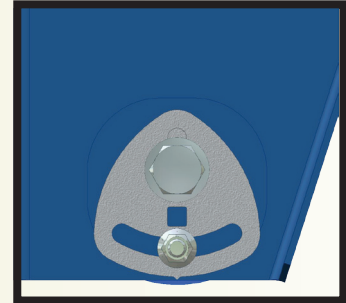

Ridewell's Speet Set™ makes manual alignment easier than ever (+/- 1/4" at hanger).

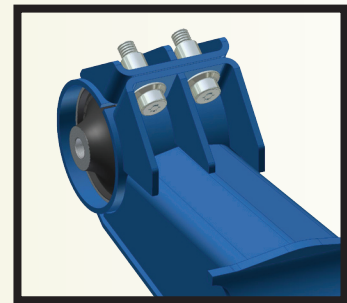
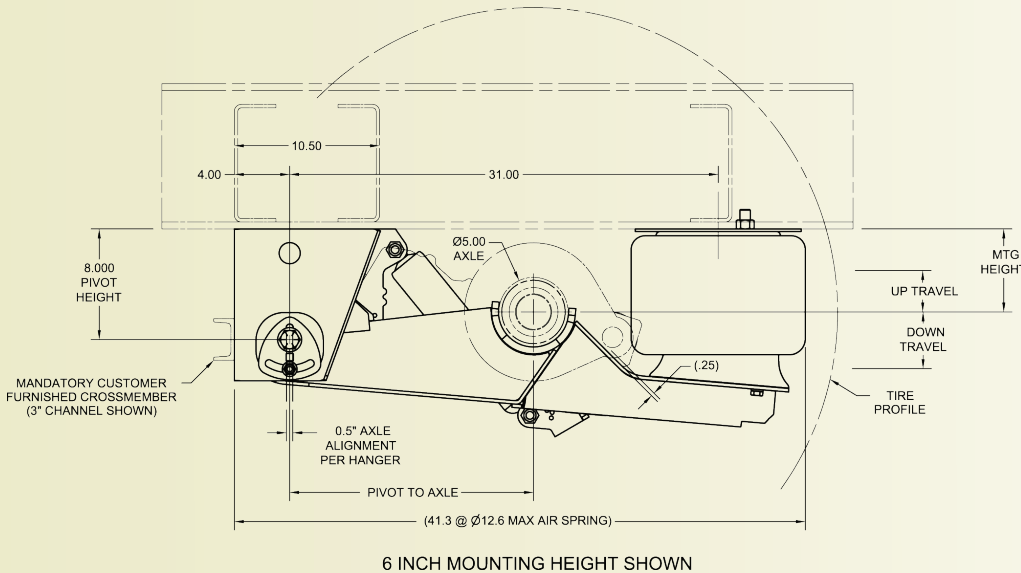

Clamp for pivot bushing cavity is lockbolted with the Huckbolt® fastening system for consistent, reliable clamp-up.

Patented contoured axle seat optimizes axle weldment by decreasing stress concentrations. No u-bolts required.

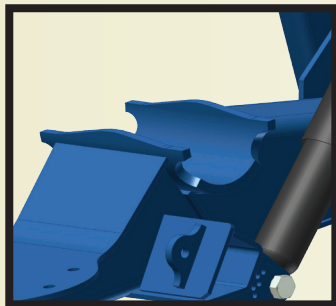

Features:

- Pre-located height control valve mounting
- Tapered rubber pivot bushing
- Patented contoured axle seat
- Integrated shock absorber mounting
- Pivot bolt requires only 450 ft-lbs. torque
- Axle alignment adjustment capability +/- 1/4" at the hanger
- Mounting heights from 5 1/2" to 9"



P.O. Box 4586 ♦ Springfield, Missouri 65808
www.ridewellcorp.com ♦ 800.641.4122 ♦ Fax 417.833.4560