

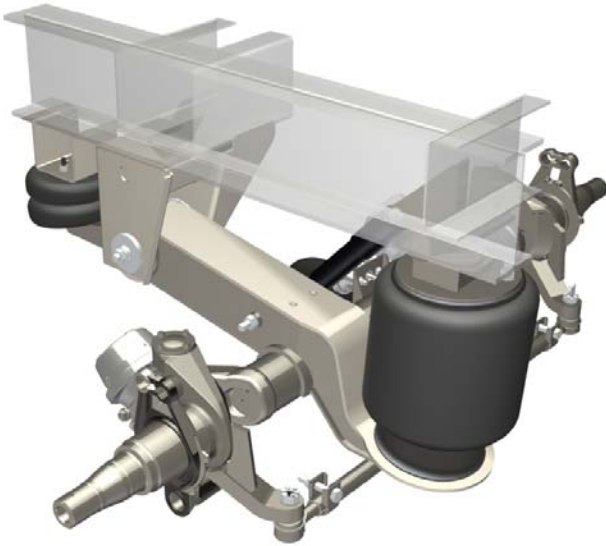

FOR IMMEDIATE RELEASE:

Ridewell Releases RAR-260-LKS

Springfield, MO – December 19, 2011 – Ridewell is pleased to announce the release of a new trailer air-ride suspension that is compatible with the use of a Leading Kingpin Steerable (LKS) axle. This liftable suspension is designed especially for the Canadian market and SPIF regulations, and is optimized for maximum up-travel for tire clearance. A lift kit comes standard with the unit. The suspension is rated for 30K lb capacity and comes with an air spring that will equalize with Ridewell's 30K lb capacity standard overslung RAR-260 or RAR-240 suspensions, without the need for a proportioning valve. The 2602917 has 6.1" up-travel to bumper contact from a 17" ride height; additional ride heights are planned. A graphic of the suspension with an LKS axle (IMT brand, 25K lb capacity) is shown below:



RAR-260-LKS

Ridewell manufactures suspensions for the truck, trailer, bus, and RV industries. The company supplies the North American community and many other countries worldwide.

For more information contact Ridewell Corporation, P.O. Box 4586, Springfield, MO 65808.
Phone: 800.641.4122, Fax: 417.833.4560, www.ridewellcorp.com

Media contact: Carey Stratton, 800.641.4122, ext. 133, cstratton@ridewellcorp.com

####