

RIDEWELL SUSPENSIONS

The Engineered Suspension Company

RAR-243

Lightweight Trailer Suspension

Owner's Manual

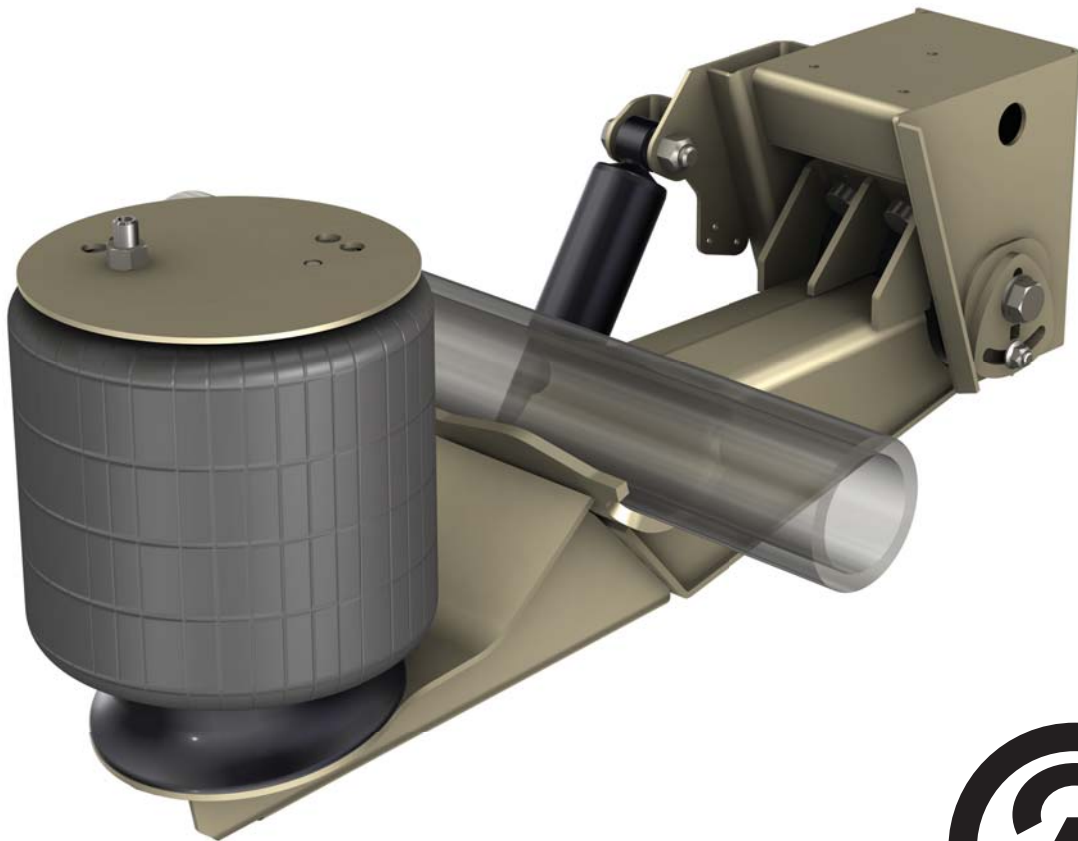

www.ridewellcorp.com

P.O. Box 4586 • Springfield, MO 65808 • 417.833.4565 • 417.833.4560 (fax)



Suspension Identification:

Ridewell Suspensions are identified by a metal tag attached to the left-hand hanger that indicates part number, revision level, & serial number.

Parts:

For optimum suspension performance, order only Ridewell parts. Replacement parts for RAR-243 are shown on page 13 of this manual.

Sales, Service & Warranty:

If you need assistance regarding this product, please contact us and we will be glad to help you.

Mailing Address

Ridewell Corporation
P.O. Box 4586
Springfield, MO 65808

Shipping Address

Ridewell Corporation
3715 East Farm Rd. 94
Springfield, MO 65803

Phones, Fax, E-mail

800.641.4122, 417.833.4565
417.833.4560 (fax)
info@ridewellcorp.com

Contents

Pre-Installation Notes.....3

Configuration.....4

Installation - General.....4

Installation - Axle to Suspension.....5

Installation - Suspension to Frame.....5

Axle Alignment.....6

Torque Requirements.....8

Height Control System Installation.....9

Bushing Check Procedure.....9

Bushing Replacement Procedure.....10-11

Maintenance Schedule.....11

Weld Process.....12

Parts Illustration.....13

Warranty.....14

Pre-Installation Notes

1. Suspensions are designed to operate within specific parameters. Operating the suspension outside the design parameters may result in improper performance, damaged equipment, and voiding of the warranty.
2. The total operating capacity of a suspension / running gear system is determined by the component with the lowest road rating. Please consult with the manufacturers of axles, brakes, tires and wheels to determine the maximum suspension system capacity. The RAR-243 suspension is rated for 25,000 lbs.
3. The installer is responsible for ensuring that air volume requirements are met. Consult Federal Motor Vehicle Safety Standards (FMVSS) 121 for more information.
4. Welding or altering suspension components is not permitted except where publicly stated by Ridewell Corporation.



Configuration

The Ridewell model RAR-243 suspension is designed to accommodate a range of ride heights for each specific model and can be used on a variety of axle types for various applications. The following characteristics are commonly referenced for set-up of the suspension:

1. **Ride Height (also called Mounting Height)** - The distance from the bottom of the trailer frame to the centerline of the axle. Ride height is related to frame height (the distance from the bottom of the frame to the ground) by the following formula:

$$\text{Ride Height} = \text{Frame Height} - \text{Loaded Tire Radius}$$

The loaded tire radius for common tire sizes can be found in **Chart 1**.

**CHART 1
TIRE LOADED RADIUS**

Tubeless	Metric	Static Loaded Radius
	215/75R17.5	14
8.5R17.5	235/75R17.5	14.5
9R17.5	225/70R19.5	15
10R17.5	245/70R19.5	15.5
	265/70R19.5	16
	285/70R19.5	16
	305/70R19.5	16.5
8R22.5	255/70R22.5	17
	245/75R22.5	17
	235/80R22.5	17
	275/70R22.5	17.5
9R22.5	265/75R22.5	18
	255/80R22.5	18
	305/70R22.5	18.5
10R22.5	295/75R22.5	19
	275/80R22.5	19
11R22.5	295/80R22.5	19.5
	315/80R22.5	19.5
	285/75R24.5	19.5
	275/80R24.5	19.5

2. **Beam Centers** - The centerline-to-centerline distance from one axle seat to the other. For the RAR-243, this is also the same as the centerline-to-centerline distance from one hanger to the other. The RAR-243 is designed to fit up onto standard I-beam trailer frames at beam centers that correspond to standard axle track widths as shown below with standard wheel-end equipment. Installation at wider beam centers will reduce suspension clearances; installation at narrower beam centers will de-rate the axle beam capacity per the axle manufacturer's specifications. For non-standard beam centers, frames, frame centers, axle track or wheel-end equipment, the installer is responsible for verifying clearances, axle capacity, proper fit-up, and any additional required support structure.

Standard Trailer Dimensions

Trailer Width	Axle Track	Frame Centers	Beam Centers	Air Spring Centers
96"	71.5"	38"	35"	31"
102"	77.5"	44"	41"	37"

Installation - General

1. See the applicable RAR-243 engineering drawing for all dimensional requirements, part numbers, assembly details, torque values, etc. referred to in the installation procedures.
2. The exact sequence of installation and assembly of the suspension, installation of the height control system, and completion of the axle alignment procedure is at the discretion of the trailer manufacturer.



Installation - Axle to Suspension

1. A fixture to support the axle and suspension during the welding process is recommended. Ridewell offers weld fixture 953386.
2. Verify the beam centers and center the axle in the axle seats.
3. For drum brake axles, space the cam off the tail of the beam per the drawing and ensure that the brake chamber brackets are oriented properly. For disc brake axles, ensure that the caliper assemblies are oriented properly and are rotated to proper position.
4. Check the gap between the axle and the bottom of the axle seat at each end of each seat. No gap greater than 1/16" allowed before clamping. After clamping the axle into the axle seats, no gap is allowed.
5. Weld the axle to the suspension trailing arms per Ridewell Weld Process #1 (see page 12).

Installation - Suspension to Frame

Note: The procedure in this section is recommended by Ridewell. Minor deviations from these guidelines are permitted, especially in the details of welding the suspension to the trailer. The installer has ultimate responsibility for attachment of the suspension to the trailer.

1. Locate and mark the proper location of the suspension hangers and air spring plates on the trailer frame. The frame must be clear in this area for proper suspension fit-up.
2. Frame cross members should be located as shown on the drawing.
3. Fabricate filler plates approximately as shown on the drawing and weld to the crossmembers with ¼" fillet welds (it is recommended to place welds down the length of the crossmember, not across it) and butt weld to frames. At the hanger, a single large filler plate in place of the two small ones may be preferable.
4. Locate and weld the hangers to the frame and filler plates with ¼" fillet welds. Stop welds approximately ½" from corners and edges. A 1.5" diameter piece of pipe may be placed through the holes in the hangers during this step as a stabilizer and aligning aide.
5. Weld the air spring support plate to the frame and filler plate in similar fashion with 3/16" fillet welds.
6. Locate a crossmember or diagonal braces to the front of the hangers as shown on the drawing and attach with ¼" fillet welds.
7. All welds to be 70 ksi min. tensile strength. GMAW or FCAW recommended.
8. Assemble air springs and shock absorbers per the drawing.



Axle Alignment

The RAR-243 suspension is equipped with the Speed-Set™ alignment feature for simple, manual alignment of the axles. There is 0.5" of available adjustment at each hanger.

1. Prior to alignment, ensure all the alignment pointers are at the 6 o'clock position. See **Figure 1**.
2. Align the forward axle to the center of the kingpin to within $\pm 1/8$ ". See **Figure 2**.
3. Alignment procedure:
 - a. Loosen the pivot nut and adjuster plate nuts.
 - b. To move the axle, insert a $1/2$ " square shank breaker bar into the square hole on the adjuster plate and push or pull. See **Figure 3**. The adjustment should be made in equal amounts on both sides of the hanger to ensure the bushing is seated squarely between the hanger sidewalls.
 - c. Snug the adjuster plate nuts and re-check alignment measurements. Adjust if necessary.
 - d. Torque the pivot nuts to 450 - 520 ft-lbs.

Note: Torque the pivot nuts with the suspension at ride height to prevent pre-stressing the rubber pivot bushing.

Note: It is imperative that the pivot nuts be fully torqued prior to placing the trailer into service. Failure to torque the pivot nuts will lead to slippage of the pivot joint, causing rapid wear of the hanger holes and the bushing sleeve, and ultimately leading to catastrophic failure of the suspension. A tag on the suspension and a label in the carton of parts are provided to specify the torque of all the suspension fasteners (see **Figure 4**). The label should be adhered to the trailer frame above the suspension. Warranty coverage of the suspension is void if the pivot nuts are not fully torqued.
 - e. Torque the adjuster plate nuts to 55 - 60 ft-lbs.
 - f. Final check the alignment measurements and re-adjust if necessary.
4. Align the aft axle(s) to the forward axle to within $\pm 1/16$ " using the same procedure. See **Figure 2**.
5. In general, small alignment changes can be made on one side (left hanger or right hanger). It is preferable that large alignment changes be made by splitting the difference from one side to the other (i.e. $1/2$ the difference forward at one hanger, $1/2$ the difference aft at the other hanger).



SPEED SET™ ALIGNMENT FEATURE

NOTICE:
ALIGNMENT POINTER
MUST BE AT 6 O'CLOCK
POSITION PRIOR TO ALIGN-
MENT. AFTER ALIGNMENT,
TORQUE ADJUSTMENT
PLATE NUT TO 55 - 60 FT. LB.
TORQUE PIVOT BOLT NUT TO
450 - 520 FT. LB.
DO NOT OVER-TORQUE!

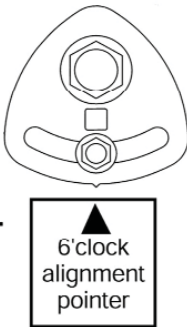

RIDEWELL CORPORATION SPRINGFIELD, MO U.S.A.

Figure 1

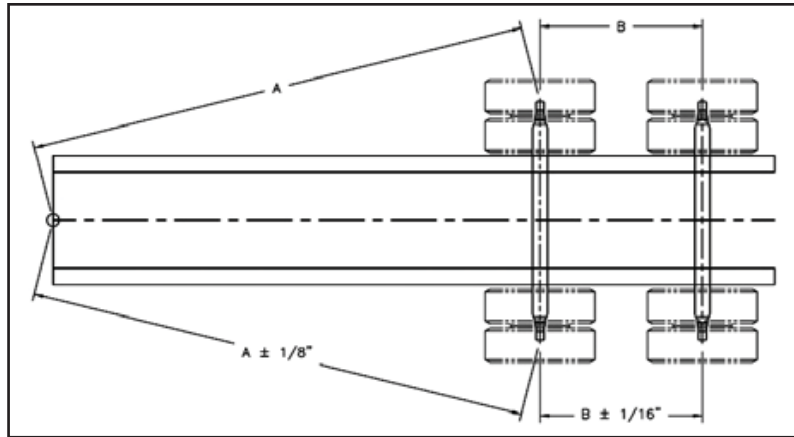

Figure 2



Figure 3



Torque Requirements

NOTICE!

- * Suspension fasteners ARE NOT at design torque.
- * Suspension installer must tighten all fasteners to design torque at the time of installation.
- * Refer to the suspension drawing and/or the torque chart on this tag for further details.

Design torque on all suspension fasteners must be SET AND MAINTAINED BY INSTALLER.

Figure 4

Monopivot 243™

RIDEWELL SUSPENSION TORQUE CHART

ITEM	SIZE	TORQUE	
		(FT-LB)	(N·m)
Pivot Bolt/Nut	7/8" - 9NC M22 - 1.5	450 - 520	600 - 700
Shock Bolt/Nut	3/4" - 10NC	200 - 230	270 - 310
Adjustment Plate Nut	1/2" - 13NC	55 - 60	75 - 80
Air Spring Nut, Upper	3/4" - 16NF	45 - 50	60 - 70
Air Spring Nut, Lower	1/2" - 13NC	45 - 50	60 - 70

After suspension has been in operation for approximately 6,000 miles (10,000 km), all fasteners must be re-tightened to specified torque. Repeat every 50,000 miles (80,000 km).

DO NOT OVER-TORQUE!



RAR-243

ITEM	SIZE	TORQUE	
Pivot Bolt/Nut	7/8" - 9NC	450 - 520 ft-lb	610 - 705 N·m
Shock Bolt/Nut	3/4" - 10NC	160 - 185 ft-lb	217 - 251 N·m
Adjustment Plate Nut	1/2" - 13NC	55 - 60 ft-lb	75 - 81 N·m
Air Spring Nut, Upper	3/4" - 16NF	45 - 50 ft-lb	61 - 68 N·m
Air Spring Bolt, Lower	1/2" - 13NC	25 - 30 ft-lb	34 - 41 N·m

After suspension has been in operation for approximately 6,000 miles (10,000 KLMS), all fasteners must be re-tightened to specific torque. Repeat every 50,000 miles (80,000 KLMS). DO NOT OVER TORQUE!

See service manual for details or call (800) 641-4122
Ridewell Corporation, Springfield, MO USA www.ridewellcorp.com

#1990019

This torque label, included in the carton of parts, should be adhered to the chassis above the suspension.



Height Control System Installation

Install the appropriate height control valve, linkages, etc. per the ExtremeAir™ Height Control Valve Installation and Operations Guide for model RAR-243 25K Underslung.

Bushing Check Procedure

The bushings in the RAR-243 suspension should be checked during any scheduled maintenance or any time there is a suspected problem. Bushing problems can arise from breakdown of the natural rubber over time or, in a severe application, by failure of the bond between the rubber and the metal inner sleeve. The bushings should be checked if any of the following conditions are observed:

1. Uneven tire wear.
2. Abnormal forward-aft or lateral movement of the axle during operation.
3. Rapid degradation of wear washers.
4. Abnormal noises coming from the suspension.

To check, insert the flat end of a pry-bar between the sidewall of the hanger and the eye of the beam. Applying moderate side load to the pry-bar, look for any relatively large or easy movement of the beam in relation to the hanger. Note that a small amount of movement under load due to deflection of the rubber is normal and acceptable. Repeat the process on the other side of the hanger. If large or easy movement is noted, drop the beams down per the bushing replacement procedure for further inspection of the bushing and replace if necessary.



Bushing Replacement Procedure

1. Raise and safely block up trailer and axle. Remove wheels and tires. Remove shock absorbers from suspension.
2. Deflate air springs and, if necessary, disconnect air control valve linkage.
3. Remove pivot nuts and bolts.
4. Rotate trailing arm beams down and out of hangers.
5. Inspect pivot holes and hanger surfaces for unusual wear or damage. Repair or replace components as required.
6. Remove Huckbolt® fasteners from bushing clamp by cutting off the collar with a torch as shown in **Figure 5**. **Note:** Huckbolt® fasteners will be replaced by conventional bolts, washers, and nuts included in the bushing replacement kit. Remove bushing assemblies.
7. Insert new bushing assemblies into the beam eyes. Install bolts, washers, and nuts as shown in **Figure 6**. Torque the nuts to 190 ft-lbs. minimum while making sure that the bushing remains centered in the beam eye. Ensure bushing clamp surfaces are closed “metal-to-metal.” Final torque nuts to 280 ft-lbs.
8. Re-assemble beams to hangers with new UHMW polyethylene wear washers placed on the inboard sides of the beams.
9. Align bushing sleeves to hanger holes and install new pivot bolts, washers, and nuts. It is recommended to coat the shank of the pivot bolt (between the head and the threads) with a thin layer of anti-seize compound. Take care to not get the anti-seize compound on the threads of the bolt or nut or under the head of the bolt.
10. Check axle alignment and re-align if necessary, per the “Axle Alignment” procedure. Torque pivot nuts to 450 - 520 ft-lbs. with the suspension at ride height.
11. Re-install shock absorbers.
12. Re-install wheels and tires.
13. If necessary, re-connect air control valve linkage and adjust ride height per the Extreme Air™ Height Control Valve and Operations Guide.

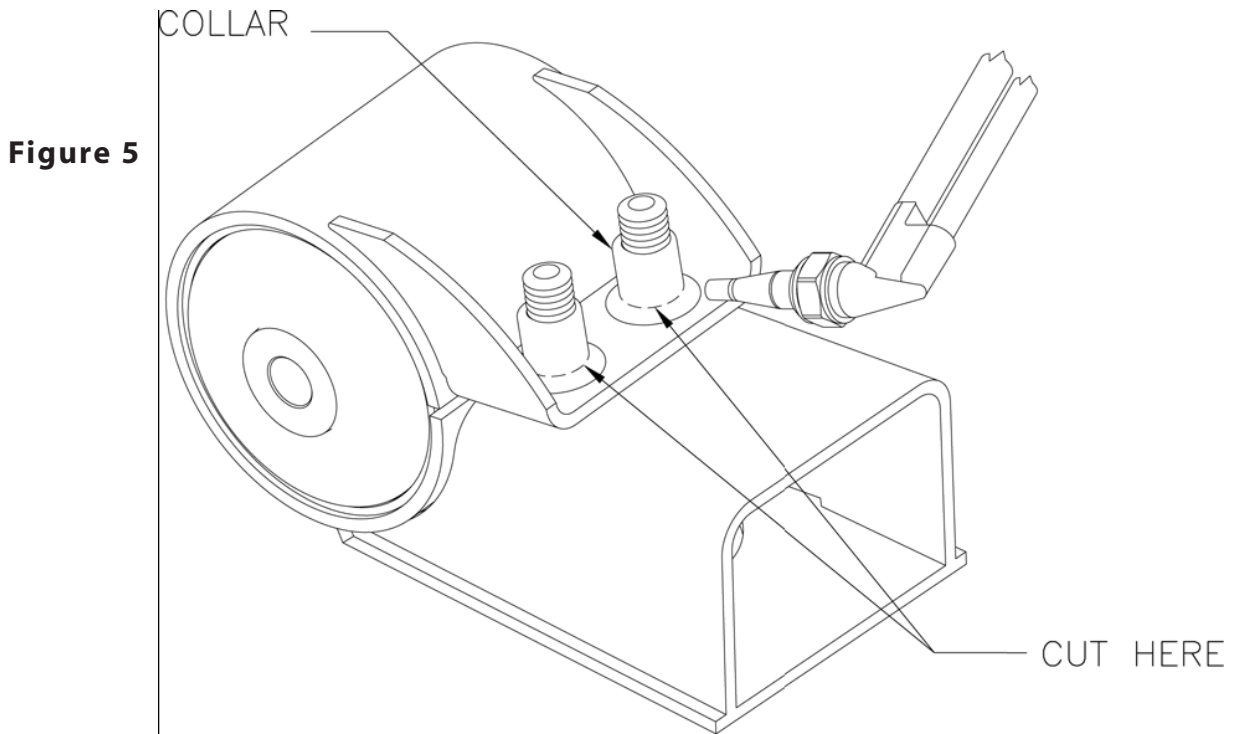

Maintenance Schedule

To keep your Ridewell suspension in optimum working order, we recommend the following maintenance:

	Every 1,000 miles	First 6,000 miles of operation	Every 12,000 miles	Every 50,000 miles
Bushings				I
Air Springs	I			
Structure	I			
Ride Height	I			
Fastener Torque		T		T

I - Inspect, L = Lubricate, T = Tighten, R = Replace



Weld Process #1

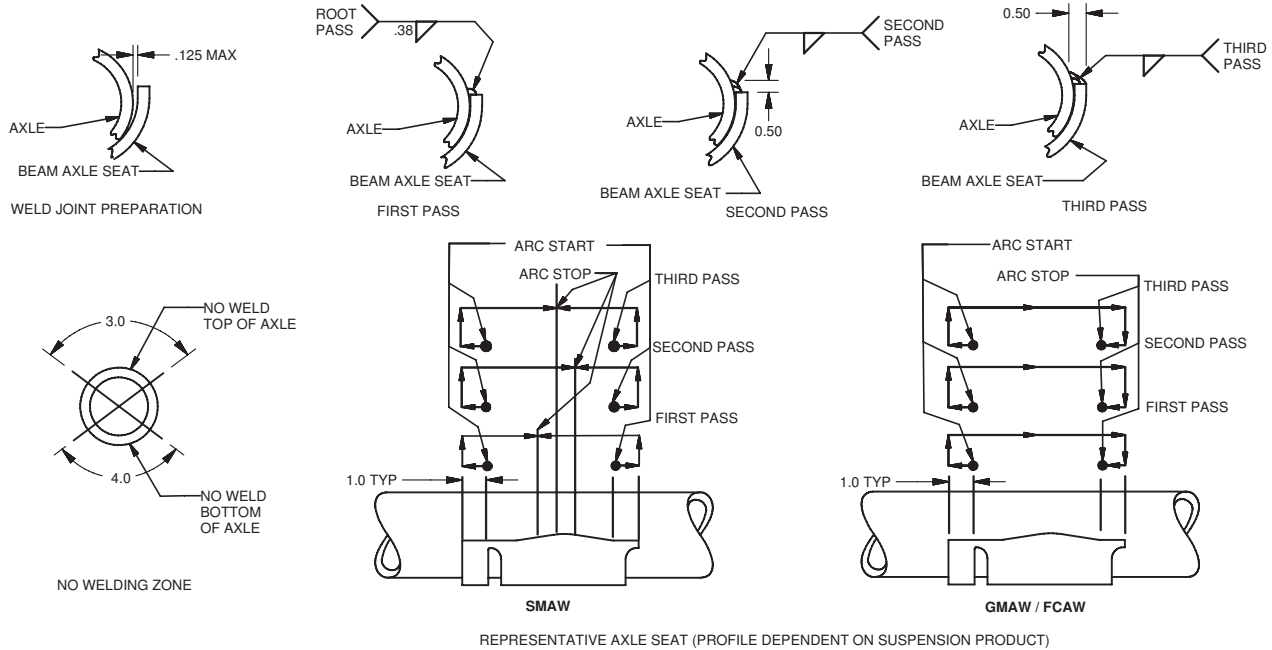

- 1 - WELD JOINT PREPARATION: ALL GREASE, DIRT, PAINT, SLAG OR OTHER CONTAMINANTS MUST BE REMOVED FROM THE WELD JOINT WITHOUT GOUGING THE AXLE TUBE. INSURE THE LOWER BEAM ASSEMBLY FITS THE AXLE WITH A ROOT GAP OF 0.125 INCH MAXIMUM BETWEEN THE AXLE AND THE BEAM AXLE SEAT AS ILLUSTRATED ABOVE. IT IS RECOMMENDED TO C-CLAMP THE AXLE TO AXLE BEAM SEAT PRIOR TO WELDING TO INSURE THAT PROPER CONTACT OCCURS BETWEEN THE AXLE AND THE BEAM SEAT. SEE ILLUSTRATION BELOW.
- 2 - WELDING PRECAUTIONS: ALL WELDS MUST BE KEPT AWAY FROM THE TOP AND BOTTOM OF THE AXLE WHERE MAXIMUM STRESSES OCCUR. THE "NO WELD" ZONES ARE ILLUSTRATED ABOVE. DO NOT TEST WELD THE ARC ON ANY PART OF THE AXLE TUBE. THIS CAN LEAD TO A SMALL CRACK THAT MAY EVENTUALLY GROW AND AFFECT THE FATIGUE LIFE OF THE AXLE.
- 3 - ALL WELDERS AND WELDING OPERATORS SHOULD BE CERTIFIED PER AMERICAN WELDING SOCIETY (AWS) D1.1 SECTION 5 PROCEDURES OR EQUAL.
- 4 - RECOMMENDED WELDING METHODS ARE SHIELDED METAL ARC (SMAW (STICK)), GAS METAL ARC (GMAW (SOLID WIRE)), OR FLUX CORED ARC (FCAW (FLUX WIRE)) WELDING. WHATEVER ELECTRODE AND METHOD USED MUST DEVELOP A MINIMUM WELD TENSILE STRENGTH OF 70,000 P.S.I. REFER TO THE ELECTRODE MANUFACTURER'S RECOMMENDATION FOR VOLTAGE, CURRENT AND SHIELDING MEDIUM FOR THE DIAMETER ELECTRODE TO BE USED SO THE BEST FUSION AND MECHANICAL PROPERTIES CAN BE OBTAINED. RECOMMENDED ELECTRODE IS E7018 IF SMAW IS USED. RECOMMENDED ELECTRODE IS E70S-1 OR E70T-1 IF GMAW OR FCAW WELDING IS USED.
- 5 - ALL ELECTRODES USED SHOULD MEET AWS SECTION 5 SPECIFICATIONS AND CLASSIFICATIONS FOR WELDING CARBON AND LOW ALLOY STEELS.
- 6 - IF SMAW ELECTRODES (STICK) ARE USED, THEY MUST BE NEW, DRY, FREE OF CONTAMINANTS AND COME FROM A STOCK THAT HAS BEEN PURCHASED AND STORED PER AWS SECTION 4.5.2, LOW HYDROGEN ELECTRODE STORAGE SPECIFICATIONS.
- 7 - GROUND THE AXLE TO ONE OF THE ATTACHED AXLE PARTS SUCH AS THE AIR CHAMBER BRACKETS, CAM BRACKETS OR BRAKE SPIDER. NEVER GROUND THE AXLE TO A WHEEL OR HUB AS THE SPINDLE BEARING MAY SUSTAIN DAMAGE.
- 8 - THE AXLE ASSEMBLY SHOULD BE AT A MINIMUM TEMPERATURE OF 60 DEGREES F (15 DEGREES C) PRIOR TO WELDING. PRE-HEATING THE WELD ZONE TO THE AXLE MANUFACTURER'S PRE-HEAT TEMPERATURE IS RECOMMENDED. THIS WILL MINIMIZE THE FORMATION OF MARTENSITIC OR BRITTLE METAL STRUCTURES IN THE FUSION LINE OR THE HEAT AFFECTED ZONE WHICH MAY CONTRIBUTE TO A PREMATURE FATIGUE FAILURE IN SERVICE.
- 9 - THE JOINT TO BE WELDED SHOULD BE POSITIONED IN THE FLAT OR HORIZONTAL POSITION.
- 10 - MULTIPLE PASS WELDING SHOULD BE USED ON THE BEAM/AXLE CONNECTION USING THE FOLLOWING GUIDELINES. TOTAL FILLET WELD SIZE SHOULD BE 0.5 INCH.
- 11 - MULTIPLE PASS WELD INITIATION AND TERMINATION SHOULD BE PERFORMED AS SHOWN ABOVE. ALL SLAG MUST BE REMOVED BETWEEN PASSES. BACKSTEP FILL ALL CRATERS. EACH PASS MUST BE ACCOMPLISHED IN ONE OR TWO SEGMENTS. NEVER START OR STOP WELDS AT THE END OF THE WELD JOINT. START WELDS AT LEAST 1" FROM END AND BACKWELD OVER THE START. WELDS MUST GO TO WITHIN 1/8" +/- 1/16" OF THE ENDS OF THE AXLE SEAT AND MUST NOT GO BEYOND OR AROUND THE ENDS.
- 12 - POST-WELD PEENING (RECOMMENDED, BUT NOT REQUIRED): NEEDLE PEEN THE ENTIRE TOE OF THE SECOND PASS, INCLUDING AROUND THE ENDS OF THE AXLE SEAT. HOLD THE NEEDLES PERPENDICULAR TO THE AXLE. A UNIFORM DIMPLED PATTERN WILL APPEAR WHEN PROPERLY PEENED.

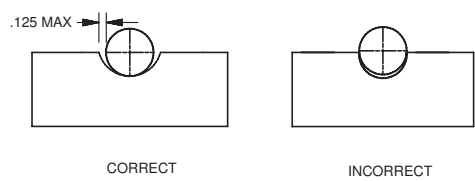

C	10102	REVISED WELD DIMENSIONS.	6/25/10	G.H.	MDJ	CJB
B	10102	REVISED NOTES 11 AND 12.	2/3/10	G.H.	MDJ	CJB
A	07100	ADDED 215 TO LIST OF SUSPENSION MODELS COVERED	2/26/07	G.H.	MDJ	DK
REV	PROJECT	DESCRIPTION	DATE	BY	CHK	APPD

DRAWN BY: CBC	6/23/2010		RIDEWELL CORPORATION PO BOX 4586 SPRINGFIELD, MISSOURI 65808
CHECKED: MDJ	2/21/2003		
APPROVED: CJB	2/21/2003		
PROJECT NO: 03103	SCALE: A-SIZE: NTS	TITLE: RIDEWELL WELD PROCESS #1, 5" DIA. AXLE, 3 PASS WELD	
MATERIAL: -	WEIGHT: -	SHEET 1 OF 1	
		PART NO: WELD PROCESS #1	REV: C

APPLICABLE SUSPENSION MODELS: 200, 225, 240, 245R, 215, 243, 260.

Figure 6

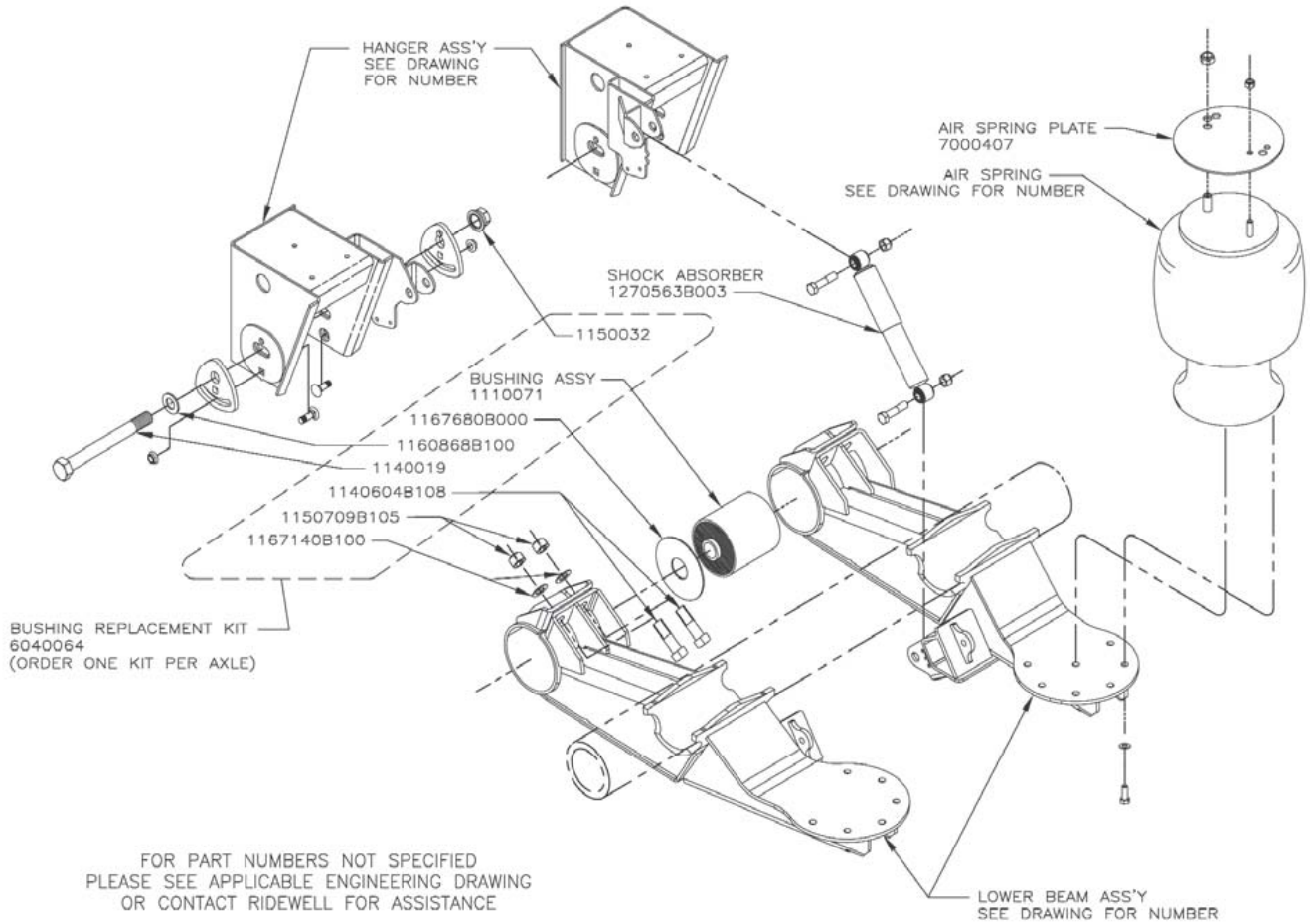



Warranty

Ridewell Suspensions warrants the suspension systems manufactured by it to be free from defects in material and workmanship, under proper use, installation, application, and maintenance on highway trailers for a period of five (5) years with no mileage limit, after delivery to the original purchaser. The responsibility of Ridewell Suspensions under this non-transferable warranty is limited to making good at the company factory by repair or replacement of any part or parts which it manufactures.

Written permission for any claim return must be first obtained from Authorized Ridewell personnel. All returns must have transportation charges prepaid by the customer and accompanied with a complete written explanation of claimed defects and the circumstances of operational failure. On all component parts not manufactured by Ridewell, their warranty is to the extent that the manufacturer of such parts warrant them to Ridewell Suspensions. This is the only authorized warranty and is in lieu of all other expressed or implied warranties or representations, including any implied warranties of merchantability or fitness, or of any obligations on the part of Ridewell Suspensions. In no event will Ridewell be liable for business interruptions, loss of profits, personal injury, cost of delay, or for other special, indirect, incidental or consequential losses, costs or damages.

Subject to all of the above conditions, if repair or replacement of any defective part is made by Ridewell Suspensions, Ridewell will return the repaired or replaced part to the original purchaser with transportation charges prepaid.

1 - 36 months 100% Parts & Labor
37 - 60 months 100% Parts Only