



**RIDEWELL
SUSPENSIONS**

(800) 641-4122

www.ridewellcorp.com



Extreme
Air
Lo-Flo

Height Control Valve Installation & Operations Guide

GENERAL INFORMATION

The Ridewell Lo-Flo Height Control Valve (HCV) is a mechanical device that automatically adds to, or exhausts, air from the air suspension when changes in vehicle load are detected. The HCV will respond to dynamic changes, but does so by limiting air consumption for small changes in suspension height.

- HCV ports use push-to-connect (PTC) fittings for 1/4" tubing.
- Dual HCV mounting is allowed. The vehicle OEM should be consulted if converting from a single to a dual HCV configuration.
- Various HCV and linkage kits are available. Contact Ridewell or the OEM for selecting the correct kit.
- The Ridewell Lo-Flo HCV is interchangeable with most other brands of valves.

PRIOR TO INSTALLATION

- Proper setup of the HCV is critical to the performance of the suspension system.
- Incorrect installation or adjustment of the HCV may result in poor performance & premature wear, or failure, of the suspension system. Please read all instructions & contact the OEM or Ridewell if any questions arise regarding proper installation.
- Adequate air supply is required for suspension performance. The OEM should specify air reservoir requirements, as well as plumbing instructions for proper system operation. Figure 3 shows a generic single plumbing arrangement.
- Be sure that there are no obstructed air lines supplying the system.
- A pressure protection valve (PPV) must be installed at the reservoir.
- For best performance, the HCV should be installed to allow lever angles between 20 and 45 degrees for full jounce & rebound conditions. Under no circumstances should the linkage system toggle upon itself during suspension movement.
- Air lines must be connected to the HCV's supply, suspension & dump ports. Proper torque of fasteners is also important. See diagrams on this sheet for port callouts and HCV torque specifications.
- The exhaust port (rubber boot end) of the HCV must be installed at, or below horizontal.
- The HCV has an alignment notch on the drive bearing cap, that when aligned with the centering hole, centers the HCV. This assists in obtaining desired suspension ride height during installation.

INSTALLATION & ADJUSTMENT INSTRUCTIONS

- Prepare the vehicle for installation by parking on a level surface and chocking the wheels to prevent movement. Failure to follow acceptable safety precautions for supporting the weight and preventing vehicle movement could result in serious injury.
- The suspension/axle system should be blocked to the desired ride height (center of axle to bottom of frame). Consult the suspension or vehicle OEM for the proper suspension ride height.
- Determine the correct orientation of the lever to the drive cap. The alignment notch on the drive bearing cap should be used to properly locate the drive cap with the lever placed in the cap slot - be sure the lever rotates up to fill ("FILL") and down to exhaust ("EXH"), as noted on the HCV body. Assemble the lever to the drive mechanism with the 1/4" tapping screw. Torque to 50-55 in-lbs.
- Prior to installation, be sure the HCV drive system rotates freely in both directions by moving the lever.
- Install the HCV on the vehicle. Place two (2) bolts into the mounting slots and mount the HCV to the vehicle frame or mounting bracket. Torque the 1/4-20 nuts to 60-80 in-lbs.
- Assemble the vertical linkage to the HCV and lower mounting bracket as shown in Figure 2. The vertical link is adjustable at the lower end - any excess rod length should be cut off. See suspension configurations for typical linkage installations and their components. Torque 1/4" and 5/16" fasteners to 60-80 and 90-120 in-lbs, respectively.
- The HCV should be in the center position prior to tightening the lower linkage connection (band clamp on "P" connector).
- Install air lines to the correct HCV ports, ensuring that air lines do not chafe on the other components. 90 degree PTC elbows that install in the HCV ports are available from Ridewell, if necessary, to redirect air lines.
- Air up the vehicle and check for leaks.
- Safely remove the mounting height blocks.

INSTALLATION & ADJUSTMENT INSTRUCTIONS CONTINUED

- Check for proper function of the HCV. Raise the suspension by manually rotating the lever 20 to 30 degrees in the "FILL" direction. Upon release of the lever, the HCV should exhaust and the suspension should return to its pre-set mounting height. Rotate the lever toward the "EXH" position 20 to 30 degrees - the suspension should return to the pre-set mounting height as the HCV adds air to the air springs. If this operation is backwards, the drive bearing cap will need to rotate 180 degrees and the lever re-positioned.
- Small adjustments may be necessary to achieve exact mounting height by adjusting the "P" connector to the vertical link.
- As a final check, be sure no linkage binding or interference is present at full jounce & rebound of the suspension system. In cases where a steer axle is used, be sure the wheels do not interfere with the HCV and linkage system when turned.

MAINTENANCE

- Routinely inspect for proper mounting height and re-adjust if necessary.
- Inspect for air leaks.
- Inspect for loose connections and re-torque fasteners as necessary.
- Inspect for chafed air lines.

Ridewell Suspensions

P.O. Box 4586, Springfield, MO USA
(800) 641-4122
www.ridewellcorp.com

FIGURE 1

Valve Configuration
(Shown with straight lever; offset lever available)

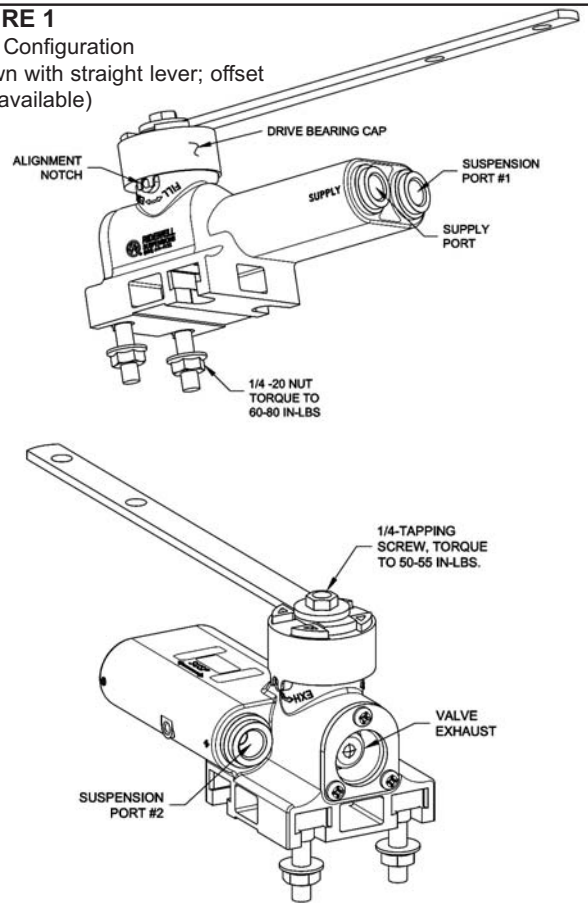
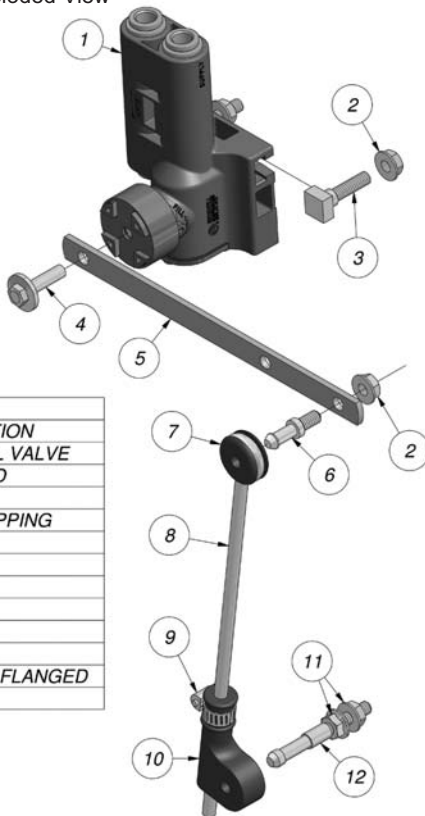

FIGURE 2

Height Control View Exploded View



ITEM	DESCRIPTION
1	HEIGHT CONTROL VALVE
2	NUT 1/4" FLANGED
3	T-BOLT 1/4"
4	SCREW, SELF-TAPPING
5	LEVER
6	UPPER PIN
7	GROMMET
8	VERTICAL LINK
9	CLAMP
10	P-CONNECTOR
11	NUT 1/4" OR 5/16" FLANGED
12	LOWER PIN

FIGURE 3

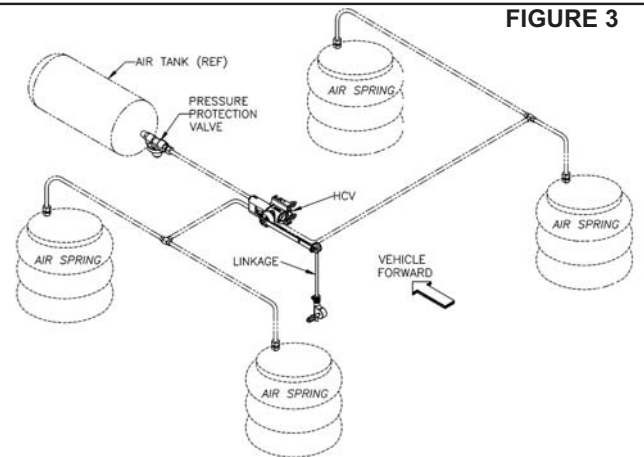

RAR-244 8K Underslung

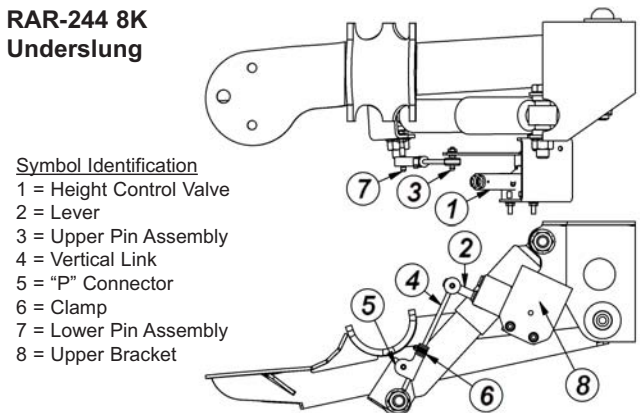

Symbol Identification

- 1 = Height Control Valve
- 2 = Lever
- 3 = Upper Pin Assembly
- 4 = Vertical Link
- 5 = "P" Connector
- 6 = Clamp
- 7 = Lower Pin Assembly
- 8 = Upper Bracket