

# RSS-2361000-Truck Suspension

## Self-Steer Air-Ride Suspension System for Customer-Supplied I-Beam Axle

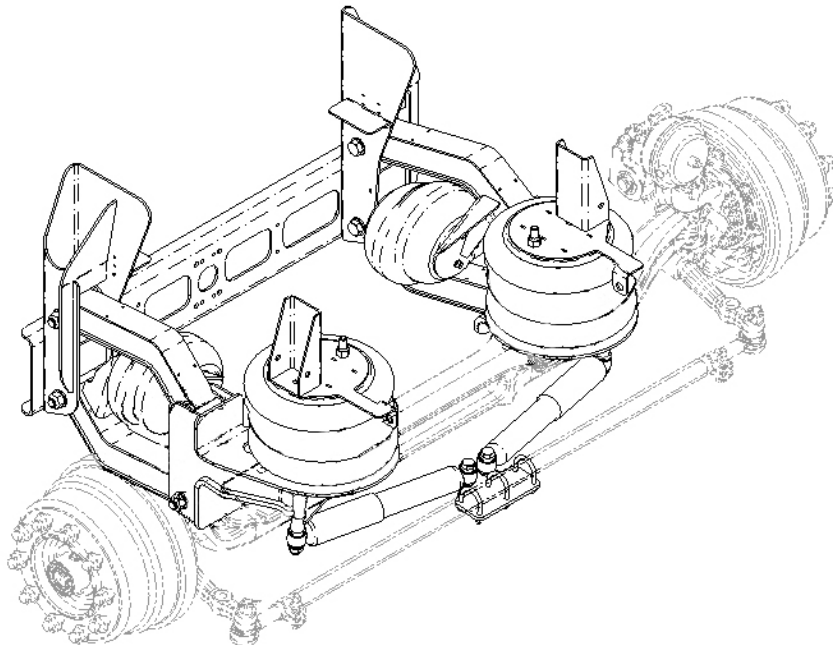

## Installation and Service Manual

<b>Suspension Identification .....</b>	<b>2</b>
<i>Suspension System Serial Tag</i>	
<i>Prior to Installation</i>	
<b>Installation .....</b>	<b>3</b>
<i>Suspension Mounting</i>	
<i>Air Controls - Troubleshooting</i>	
<b>Maintenance .....</b>	<b>5</b>
<i>Recommended Service Intervals</i>	
<i>Parts Illustration</i>	
<i>Suspension System without Axle</i>	
<i>Torque Specifications</i>	
<i>Bushing Replacement Procedure</i>	
<b>Warranty .....</b>	<b>8</b>



Part No.: 9710118

Doc: 2361000-Truck-ISM-05-11-17

## SUSPENSION IDENTIFICATION

The Ridewell Self-Steering (RSS) 2361000 Truck Suspension is a liftable suspension system for field integration with a customer-supplied I-Beam Axle.

### Identification Tag

Ridewell systems can be identified by the Part and Serial Number listed on the serial identification tags.

### Suspension Serial Tag

The Suspension Serial Tag provides information on the suspension model (Figure 1).

The **Part Number (236xxxx)** refers to the individual model of the suspension system.

The nine-digit **Serial Number (1xxxxxxx)** refers to the date and order of manufacture of the suspension. Please refer to both the part number and serial number when contacting Ridewell for customer service, replacement parts and warranty information.

### Notes and Cautions

All work should be performed by a properly trained technician using the proper/special tools and safe work procedures.

The ISM uses two types of service notes to provide important safety guidelines, prevent equipment damage and make sure that the suspension system operates correctly. The service notes are defined as:

“NOTE”: Provides additional instructions or procedures to complete tasks and make sure that the suspension functions properly.

**CAUTION** Indicates a hazardous situation or unsafe practice that, if not avoided, could result in equipment damage and serious injury.

### Notes on Self-Steering Option

Self-steering suspensions are designed to steer only in the forward direction. The suspension should be raised off the ground or locked into a non-steering configuration during reverse travel to avoid damaging the suspension.

Ridewell Suspensions strongly recommends the use of automated systems that raise/lock the lift-axle during reverse travel. For manual operations, Ridewell recommends the installation of a visual/audible indicator to assist the driver.

**CAUTION** Failure to lift the suspension and-or engage the steering-lock during reverse travel can cause component damage and void the warranty.



**Figure 1. The Suspension Serial Tag is located on the left-hand (driver's side) suspension hanger.**

### Prior to Installation

Installations can vary and procedures should be adapted for different vehicles, as needed.

- The Gross Axle Weight Rating (GAWR) is determined by the system component with the lowest load rating. Please consult with tire, wheel, axle and brake manufacturers before installation to determine the GAWR.
- If vehicle chassis modifications are required, consult with the vehicle manufacturer to ensure that such changes are permitted.
- Welding or altering suspension components is not permitted without the express written permission of Ridewell Suspensions.

### Installer Responsibilities

The suspension installer has sole responsibility for proper attachment of the suspension to the chassis.

- The installer must verify that vehicle crossmembers are positioned to support the suspension at the installing location.
- It is the installer's responsibility to determine that axle spacing conforms to any applicable federal and local bridge laws.
- The installer must verify that air reservoir volume requirements are met. Consult the vehicle manufacturer or Federal Motor Vehicle Safety Standards (FMVSS) 121 for more information.
- The installer must verify there is sufficient clearance for proper functioning of the auxiliary suspension, air springs, brake chambers, steering components, axle (including axle to driveline clearance) and tires.

## Mounting the suspension to the frame

Refer to steering damper kit engineering drawing for axle configurations and suspension clearance requirements. Load Beam Assembly (LBA), steering damper kit and mounting hardware for customer-supplied I-Beam axle are included with suspension.

Ride height is adjusted by installing 1" or 2" spacers on the air spring mounting brackets and adjusting the height of the hanger mounting flanges.

NOTE: Hanger mounting flanges are pre-installed to match the ride height of the air spring brackets mounted without spacers.

### Bolt-On Installation Procedure

Grade 8 bolts and flanged lock nuts or lock nuts with hardened washers are required for installation.

1. Place the suspension (with hanger and air spring filler plates and the appropriate spacer(s), if required) in the desired location.  
NOTE: A crossmember must be located on the frame within six inches of the leading or trailing edge of the hanger.
2. Check that the location provides adequate clearance for suspension components. Make sure the top of the hangers and air spring mounting plates are parallel to the chassis frame to maintain the proper caster angle.
3. Hangers and air spring mounting plates should be perpendicular to the chassis frame and in alignment with each other. Clamp the hangers, mounting plates, and spacer and filler plates (if required) firmly in place.
4. Refer to the engineering drawing for the recommended bolt hole locations on the hangers and air spring mounting plates. If it is not possible to use the recommended bolt locations, space the bolt holes as far apart as possible to provide the greatest support for the suspension.  
**CAUTION** Check to make sure that wires, hoses or other components located within the frame rail are not affected by drilling.
5. Center punch and drill bolt holes in each hanger. Center punch and drill bolt holes in each air spring mounting bracket. Bolt the hangers and air spring mounting brackets to the frame.
6. **Axle installation procedure:** Match drill holes from axle to load beam assembly (LBA). Make sure that the axle is correctly centered on chassis. Clamp into place.

7. Attach the axle to the load beam assemblies using 3/4" Hex Head Cap Screw (HHCS), flat washers and lock nuts. Torque to specifications.  
**CAUTION** The axle turn-stop bolts may need to be adjusted to restrict the turn angle and prevent interference with suspension components.
8. Install/connect the air control kit (ACK) to the suspension (Page 4). Check the air system after installation for leaks.
9. Verify all suspension component bolts/nuts are torqued to specifications (Chart on pg 7).
10. Raise and lower the suspension assembly (wheels and tires installed) through the entire range of travel. Make sure that sufficient clearances for air springs, brake chambers and other components has been provided.
11. Check automated system (if installed) to make sure that suspension raises/locks wheels during reverse travel.

**CAUTION** Failure to torque bolts/nuts of suspension components to specifications can result in failure of the suspension and void the warranty.

**CAUTION** Do not lower the auxiliary axle while the vehicle is moving in forward or reverse above 10 mph.

**CAUTION** Failure to check reverse travel operations can result in component damage and void the suspension warranty.

### Air springs pressure regulates axle load

The load capacity of the auxiliary axle is adjusted by increasing or decreasing the pressure to the air springs. By applying more air, the lift axle takes on a greater percentage of the load's weight. The load capacity is decreased as the air pressure decreases.

Accurate readings of the load capacity can be obtained by parking a loaded vehicle over a calibrated scale and lowering the axle onto the scale. The air pressure to the air springs is manually adjusted up or down to obtain the axle load weight at various air pressures.

**CAUTION** Do not exceed the rated load capacity of the suspension system or other components. Exceeding the capacity can cause component failure and void the warranty.

## Install air system components

Connect the load and lift air springs and an air control kit to the air system (Figure 2).

The air control kit (ACK) consists of a pressure regulator with a gauge connected to an air valve controlled by an electric switch or manual knob. The ACK allows the operator to control the air spring pressure so that the auxiliary axle can support different loads.

Ridewell has a number of manual/electric ACK configurations available. Installation will vary by the type of configuration.

**⚠ CAUTION** The installer is responsible for making sure that air system requirements comply with the appropriate Federal Motor Vehicle Safety Standards.

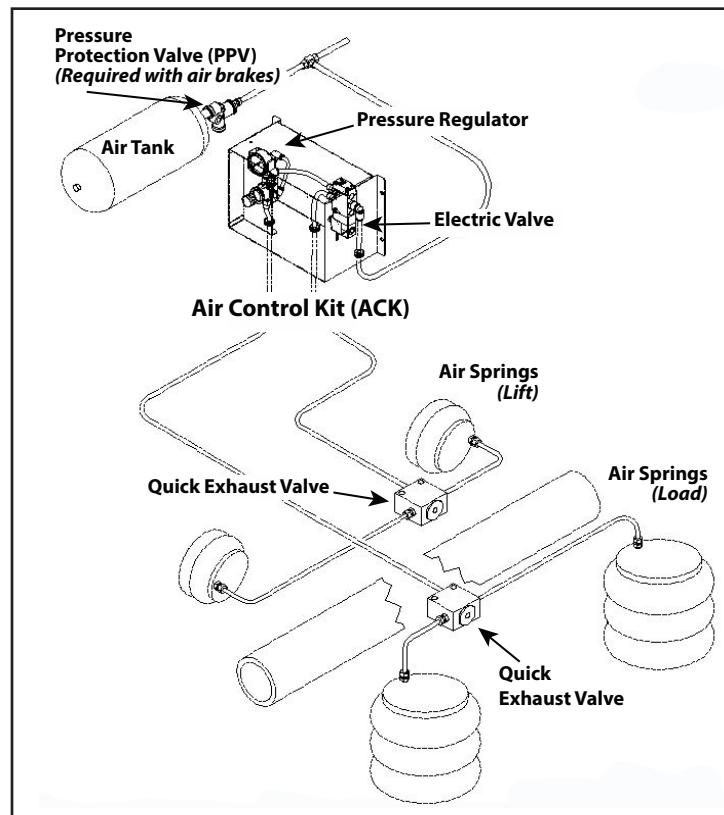

**Figure 2.**  
Example of Air Control Kit (ACK) installation

## Troubleshooting – Air System Installation

Problem	Possible Cause	Solution
<b>Air springs fill but do not exhaust.</b>	<ul style="list-style-type: none"> <li>– Obstructed air line.</li> <li>– Faulty controls wiring.</li> <li>– Manual override pushed in</li> </ul>	<ul style="list-style-type: none"> <li>– Check for pinched/blocked lines.</li> <li>– Check wiring with voltmeter and correct wiring/installation.</li> <li>– Release manual override.</li> </ul>
<b>Air system leaks down after a short period of time.</b>	<ul style="list-style-type: none"> <li>– Leak in air system beyond accepted standards.</li> </ul>	<ul style="list-style-type: none"> <li>– Pressurize system and spray soap water solution onto the tubing, valves and fittings. Check for bubbles (leaks). Note: Some valves will leak at an acceptable rate.</li> <li>– Check that tubing cuts are straight and smooth. Re-cut and reassemble fitting joints, if necessary.</li> </ul>
<b>Auxiliary unit will not stay up</b>	<ul style="list-style-type: none"> <li>– Loose Air Fittings.</li> <li>– Damaged Air Lines.</li> <li>– Air lines to lift and load air springs are reversed.</li> <li>– Damaged or Worn Air Springs.</li> </ul>	<ul style="list-style-type: none"> <li>– Check and retighten fittings. Repair or replace component, as necessary.</li> <li>– Check installation. Air line from regulator goes to (load) air springs.</li> <li>– Replace if worn or damaged.</li> </ul>
<b>Auxiliary unit not getting the correct lift</b>	<ul style="list-style-type: none"> <li>– Air lines to lift and load air springs are reversed.</li> <li>– Lift air springs do not have proper air pressure.</li> <li>– Interference with driveline or other chassis components.</li> <li>– Air control system not installed correctly.</li> </ul>	<ul style="list-style-type: none"> <li>– Check installation. Air line from regulator goes to (load) air springs.</li> <li>– Check for loose fittings or worn/damaged lines. Verify air tank pressure with gauge.</li> <li>– Visually inspect unit operation for proper clearance. Check for loose fasteners and retighten.</li> <li>– Check installation; refer to OEM installation procedures.</li> </ul>

A visual inspection of the suspension structure should be performed during each pre-trip/safety inspection. Ridewell Suspensions recommends the following minimum service intervals for standard duty, on-highway usage applications. More frequent intervals are recommended for heavier duty applications.

---

### Daily/Pre-Trip Inspections

---

- \_\_\_ Check tires for proper inflation, damage or excessive wear.
- \_\_\_ Check wheel-ends for obvious signs of lubricant leakage. Check for missing components.
- \_\_\_ Visually inspect suspension structure for signs of damage or excessive wear.
- \_\_\_ Check for loose or missing bolts/nuts. Check for irregular movement in suspension components.
- \_\_\_ Make sure air controls are operating properly. Drain all moisture from air reservoirs.

---

### First 6,000 miles of use

---

- \_\_\_ Torque all suspension bolts/nuts to specifications (torque values chart in Appendix).

---

### Every 12,000 miles of use

---

- \_\_\_ Lubricate Brake Cam and Slack Adjuster.
- \_\_\_ Inspect kingpins and upper/lower kingpin bushings for wear. Grease thrust bearings.
- \_\_\_ Inspect steering damper for damage/wear.
- \_\_\_ Inspect air springs for any damage or excessive wear. Torque air spring bolts/nuts to specifications (Appendix).
- \_\_\_ Check air system for leaks.

---

### First 50,000 miles of use

---

- \_\_\_ Torque all suspension bolts/nuts to specifications (Appendix).
- \_\_\_ Check wheel ends for excessive play.
- \_\_\_ Check suspension pivot bushings for wear.
- \_\_\_ Check operation of (reverse) steering lock (if equipped).
- \_\_\_ Verify operation of manual/automatic lift-in-reverse control (if equipped).
- \_\_\_ Inspect tie-rod and tie-rod ends for damage and wear. Lubricate tie-rod ends. Check that the tie-rod boot is in place and completely over the end of the tie-rod. Replace entire tie-rod end if boot is damaged.

---

### Annually/100,000 miles of use

---

- \_\_\_ Inspect pivot connections for worn pivot bushings and replace, if necessary. Torque pivot hardware and component bolts/nuts to specifications (Appendix).
- \_\_\_ Check suspension hanger and air spring mounting plate connections to frame.
- \_\_\_ Check lubrication level in wheel ends:
  - 1) Oil-Filled Wheel Ends: Refill/Replace lubricant as needed (Refer to TMC RP 631 "100K/Annual Inspection").
  - 2) Semi-Fluid Grease: Pull outer bearing and visually inspect lubrication level. Refill/Replace as needed (Refer to TMC RP 631 "Level 3 Lubrication Level Inspection" and TMC RP 618 "Wheel Bearing Adjustment Procedure").
- \_\_\_ Check air system for leaks.
- \_\_\_ Test air system pressure protection valve (if equipped).
- \_\_\_ Check brake chambers and brakes for damage and proper function.

**⚠ CAUTION** Failure to exhaust all pressure from the air system before working on the vehicle can cause serious injury.

**⚠ CAUTION** Failure to torque bolts/nuts of suspension components to specifications can result in failure of the suspension and void the warranty.

Refer to the following Technology & Maintenance Council (TMC) publications for additional maintenance information.	
TMC RP 609	Self-Adjusting and Manual Brake Adjuster Removal, Installation and Maintenance
TMC RP 618	Wheel Bearing Adjustment Procedures
TMC RP 619	Air System Inspection Procedure
TMC RP 622	Wheel Seal and Bearing Removal, Installation, and Maintenance
TMC RP 631	Recommendations for Wheel End Lubrication
TMC RP 643	Air Ride Suspension Maintenance Guidelines
TMC RP 645	Tie Rod End Inspection and Maintenance Procedure
TMC RP 651	Steer Axle Maintenance Guidelines

**NOTE:**  
 Spacer Kit includes  
 air spring spacer plates only

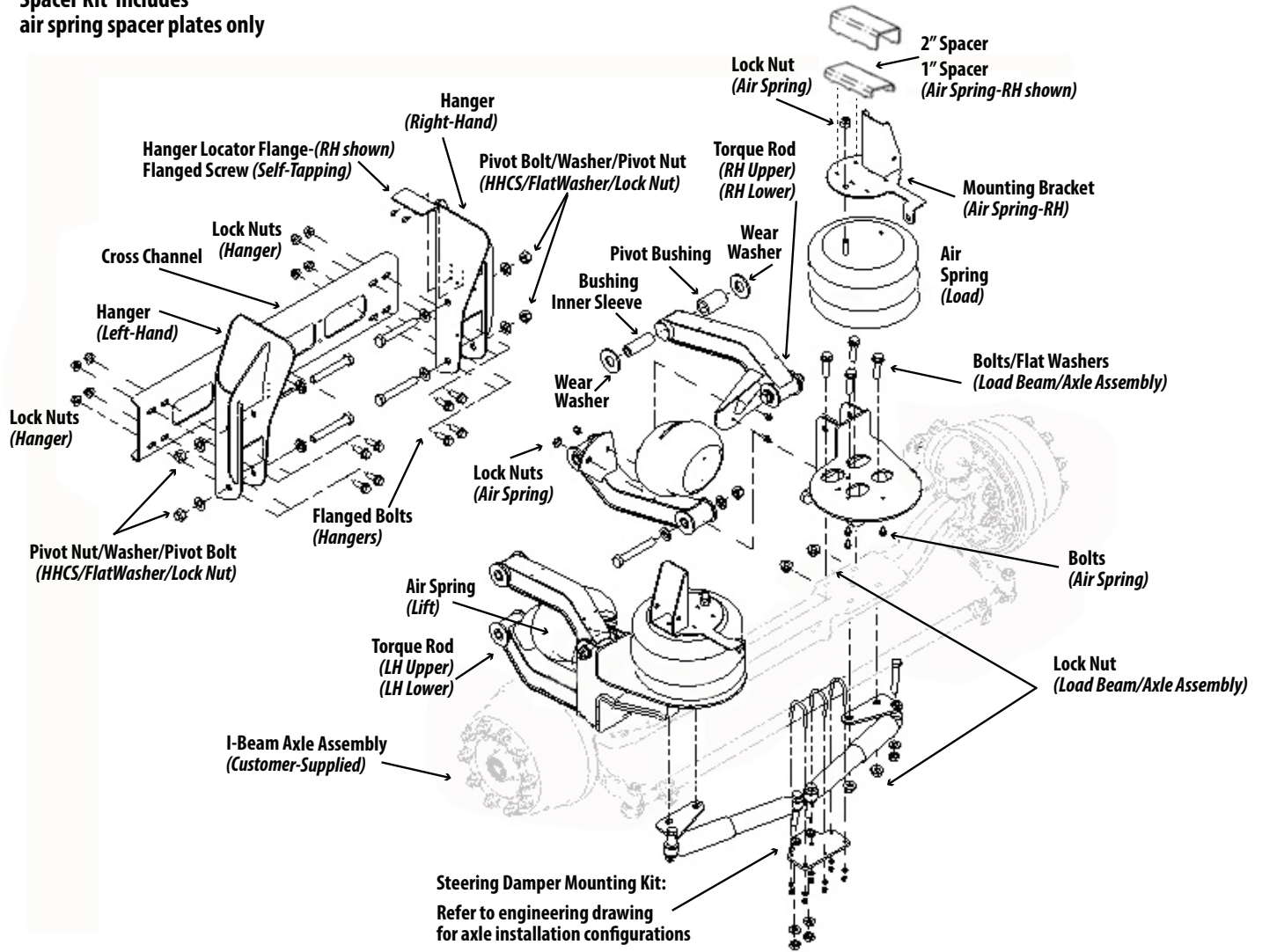

**Figure 3.**  
 RSS-2361000 - 13.5K Truck Suspension (Customer-Supplied I-Beam Axle)  
 Refer to the engineering drawing for the individual component part number.

## 2361000 - Self-Steer Truck Suspension – Torque Specifications

Fastener Type	Size	Torque Specifications	
		foot-pound	Newton-meter
Pivot Bolt - (Hex Head Cap Screw (HHCS)) Pivot Nut - (Lock Nut)	7/8"-14NF	500 ft-lb	678 N-m
HHCS/Lock Nut - (Cross Channel)	5/8"-11NC	160 ft-lb	217 N-m
Lock Nut - (Load Beam Axle Assembly)	3/4"-16NF	310 ft-lb	420 N-m
Lock Nut - (Air Spring)	3/4"-16NF	50 ft-lb	68 N-m
Flanged Lock-Screw - (Air Spring)	3/8"-16NC	25 ft-lb	34 N-m
HHCS/ Lock Nut (Steer Damper)	3/4"-10NC	160 ft-lb	217 N-m
Lock Nut - (U-Bolt-Steer Damper Mount)	3/8"-16NC	30 ft-lb	41 N-m

Torque values reflect a lubricated thread condition (Nuts are pre-lubed). Do not overtorque.

**CAUTION** Suspension is shipped with minimal torque applied to fasteners. It is the installer's responsibility to apply the proper torque values. Failure to install and maintain fasteners at torque specifications could result in suspension failure and voiding of the warranty. Refer to the engineering drawing for torque specifications.

## Bushing Replacement Procedure

Park the vehicle on a level surface. Chock wheels to keep vehicle from moving. Exhaust all the air from the air system. Disassemble suspension, if necessary, to reach the pivot connections.

**CAUTION** Failure to properly chock wheels and exhaust the air system could allow vehicle movement that could result in serious injury.

- Remove pivot hardware and discard. NOTE: New hardware included in replacement kit (6040161).
- Inspect wear washers for excessive wear/damage. Replace, if necessary.
- Remove bushing assembly from the torque rod and discard. Clean the rod eye of any foreign debris or corrosion.
- Apply Energy Suspensions® Formula 5 Prelube to the bore (inside) of new bushings. NOTE: Do not substitute - special urethane bushing lubricant included with all bushing kits.
- Install bushing in the eye of the torque rod. NOTE: Mallet/press may be needed.
- Press inner sleeve into the installed bushing. Center the sleeve inside the bushing so that both ends extend slightly past the sides of the bushing equally on both sides.
- Assemble the pivot connection with one wear washer on each side of the bushing (Figure 4). Inner sleeve must be flush with or extend slightly past the outside of the wear washers.
- Torque the pivot nut to specifications (500 ft-lb - 678 N-m).
- Reassemble suspension, if necessary. Torque components to specifications (see chart).
- Check wheel toe-in setting (between 1/32" and 3/32") and adjust, if necessary.

### Bushing Replacement Kits

Bushing Replacement Kit w/o Hdwr (6040160)  
Bushing Kit with Hardware (6040161)

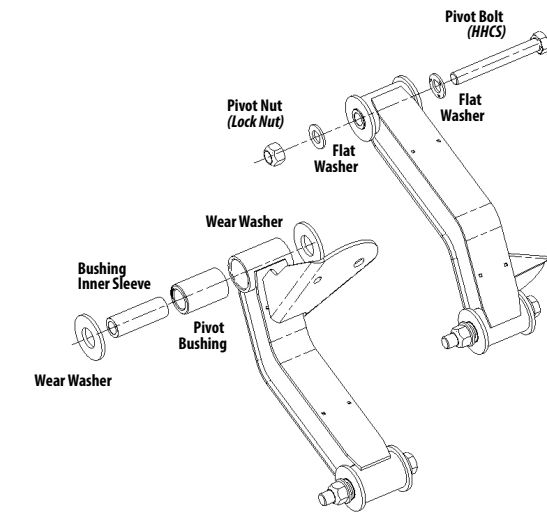

**Figure 4.** Bushing kit with/without hardware includes components for eight (8) pivot connections.

## WARRANTY

### **Terms and coverage in this warranty apply only to the United States and Canada.**

Ridewell Suspensions warrants the suspension systems manufactured by it to be free of defects in material and workmanship. Warranty coverage applies only to suspensions that have been properly installed, maintained and operated within the rated capacity and recommended application of the suspension. The responsibility for warranty coverage is limited to the repair/replacement of suspension parts. The liability for coverage of purchased components is limited to the original warranty coverage extended by the manufacturer of the purchased part.

All work under warranty must have prior written approval from the Ridewell warranty department. Ridewell has the sole discretion and authority to approve or deny a claim and authorize the repair or replacement of suspension parts. All parts must be held until the warranty claim is closed.

Parts that need to be returned for warranty evaluation will be issued a Returned Materials Authorization (RMA). Parts must be returned to Ridewell with the transportation charges prepaid. The transportation charges will be reimbursed if the warranty claim is approved.

This non-transferable warranty is in lieu of all other expressed or implied warranties or representations, including any implied warranties of merchantability or fitness or any obligations on the part of Ridewell. Ridewell will not be liable for any business interruptions, loss of profits, personal injury, any costs of travel delays or for any other special, indirect, incidental or consequential losses, costs or damages caused by Ridewell.

**Contact the Ridewell Warranty Dept. at 417.833.4565 - Ext. 135, for complete warranty information.**