

Extreme Air™



Height Control Valve Kit Installation Guide



Part No.: 9710008

Doc: HCV-Install-RevJ-09-23-16

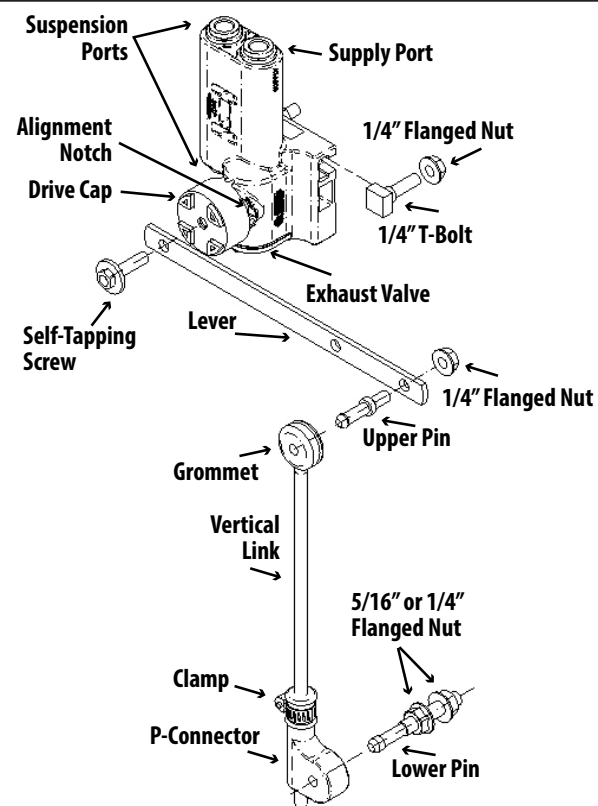

Figure 1. Refer to engineering drawing 63300AAA00-R for available height control kits.

Pressure Dump Valve Configurations (Offset Lever Shown)

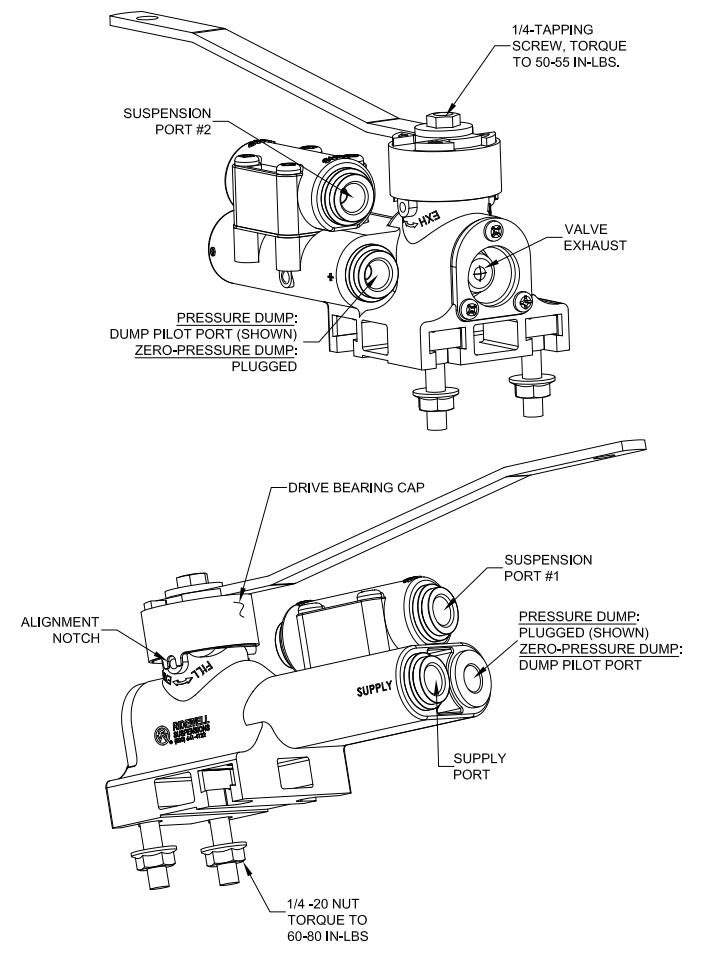

Figure 2. Pressure-Dump (Normally Open), Zero-Pressure Dump (Normally Closed) and Non-Dump HCV configurations are available. The Extreme Air™ Lo-Flo is available for air control systems that need a slower reacting, slower flowing Height Control Valve.

Pre-Installation Notes

- A pressure protection valve (PPV) must be installed at the air reservoir, when the reservoir is shared with air brakes.
- The exhaust port (rubber boot end) of the height control valve (HCV) must be installed at, or below, the horizontal position.
- All HCV ports use push-to-connect (PTC) fittings to connect to 3/8" tubing.
- The dump pilot port cannot be plugged in the Pressure-Dump valve configuration. The pilot port must be plumbed with at least 6" of air line open to atmosphere at one end.
- NOTE: The dump pilot port must be plumbed in the Zero-Pressure Dump configuration. The Zero-Pressure Dump HCV requires a pressure of 75 psi to operate.
- The installer is responsible for making sure that air system requirements comply with the Federal Motor Vehicle Safety Standards (FMVSS) 121 for Air Brake Systems.

Service Notes:

Always wear safety glasses and other required personal protective equipment when working on the air system. Park vehicle on a flat, level, debris-free surface. Chock the vehicle wheels to prevent movement. Raise the suspension/axle system to the desired ride height and support.

CAUTION Failure to provide proper support, chock vehicle's wheels or exhaust the air system could allow vehicle movement that could result in serious injury.

Height Control Kit (HCK) Installation Procedure

Refer to the vehicle or suspension manufacturers instructions for mounting position and valve orientation (Figure 5). Inspect all air line tubing, fittings and components for air leaks and repair before installation.

1. Check location of alignment notch on drive cap, place lever arm into drive cap slots and attach lever (Figure 2). Torque screw to 50-55 in-lbs. Make sure lever arm rotates up to fill ("FILL") and down to exhaust ("EXH").
2. Mount the height control valve (HCV) with lever arm to the vehicle frame or mounting bracket with two T-bolts (Figure 3). Torque to 60-80 in-lbs.
3. Attach the vertical link "P-Connector" to the lower mounting bracket with lower pin. Torque to 90-120 in-lbs. Make sure lever arm in the center position, slide vertical link (rod) up-or-down through P-Connector until grommet is at the same height as lever arm. Connect vertical linkage to lever with upper pin. Torque to 60-80 in-lbs.
4. Slide vertical link up-or-down through the P-Connector until lever arm reaches desired angle (Figure 3). Tighten the band clamp on the P-Connector to hold vertical link in place. Leave approximately 1" of the rod beneath the "P" connector and cut off excess.
5. Install air lines to the HCV supply port and the suspension and dump ports (Figure 2)
6. Pressurize air system and check for leaks (Figure 6).
7. Remove the suspension/axle system supports. Lower suspension/axle to ground.

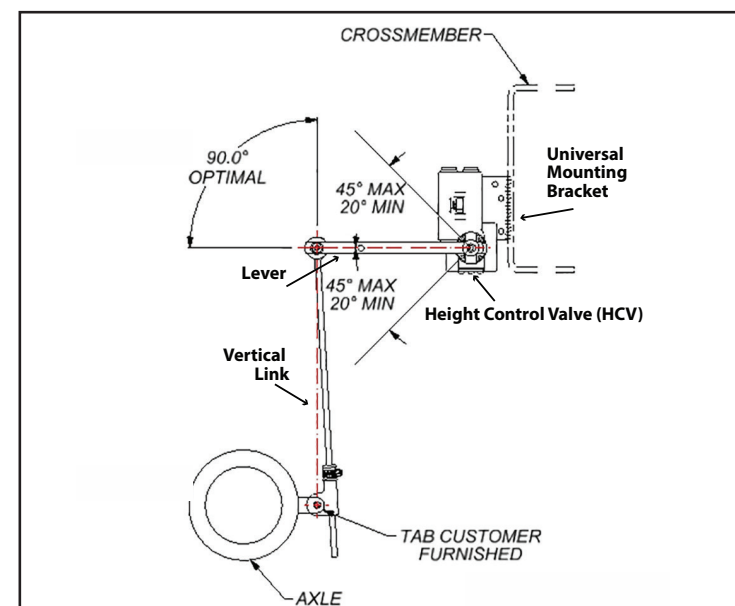

Figure 3. HCV-to-lever angles between 20- and 45-degrees provide full jounce and rebound travel.

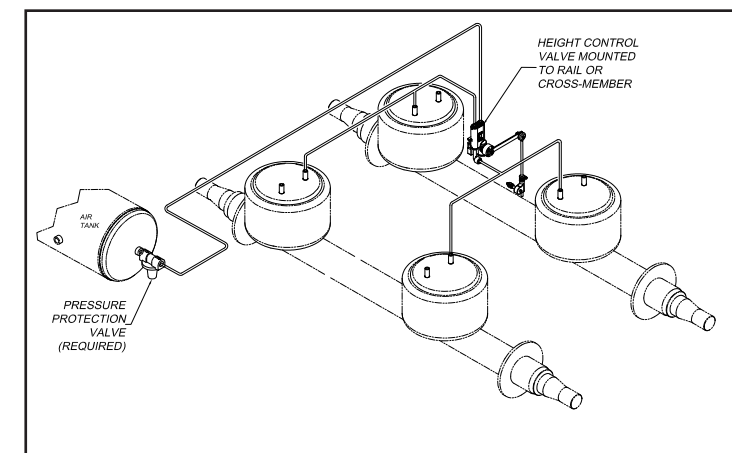

Figure 4. Example of Height Control Valve (HCV) installation on vehicle frame with linkage attached to the axle.

8. Move suspension through entire travel range to ensure no linkage binding, toggling or interference is present at full jounce and rebound of the suspension system.

Operational Check

Raise the suspension by manually rotating the lever arm 20-30 degrees towards the "FILL" position. Hold lever in place until air springs inflate. Release the lever to exhaust air springs. If air springs do not inflate:

- Verify air supply pressure is sufficient to open the pressure protection valve (usually greater than 70 psi).
- Check to make sure that any suspension dump/exhaust feature is not activated.
- Check to make sure lever is oriented properly. The drive bearing cap may need to be rotated 180 degrees and the lever re-positioned.

If air springs are inflating properly, manually rotate the lever arm 20-30 degrees towards the "EXH" (Exhaust) position. Hold lever in place and check that air is escaping from the exhaust port.

CAUTION If steer axle is used, be sure the wheels do not interfere with the HCV and linkage system when turned.

Maintenance

- Drain all moisture from air reservoir at regular intervals.
- Periodically check for pinched/damaged lines or loose fittings on components that could cause an air leak in the system. Repair any problems found.
- Routinely inspect the HCK system to make sure that the HCV is maintaining the desired ride height. Adjust the linkage and re-torque fasteners as necessary.

Ridewell suggests the following Technology & Maintenance Council (TMC) publications:

TMC RP 619B Air System Inspection Procedure

TMC RP 634A Ride Height Concerns and Adjustment Procedures for Truck/Tractor Air Ride Suspensions

Figure 5.
EXAMPLES: Common
Height Control Kit (HCK)
installations.

No	Description	No	Description	No	Description
1	Height Control Valve	4	Vertical Link	7	Lower Pin Assembly
2	Lever	5	"P" Connector	8	Lower Mounting Bracket
3	Upper Pin Assembly	6	Clamp	9	Upper Mounting Bracket

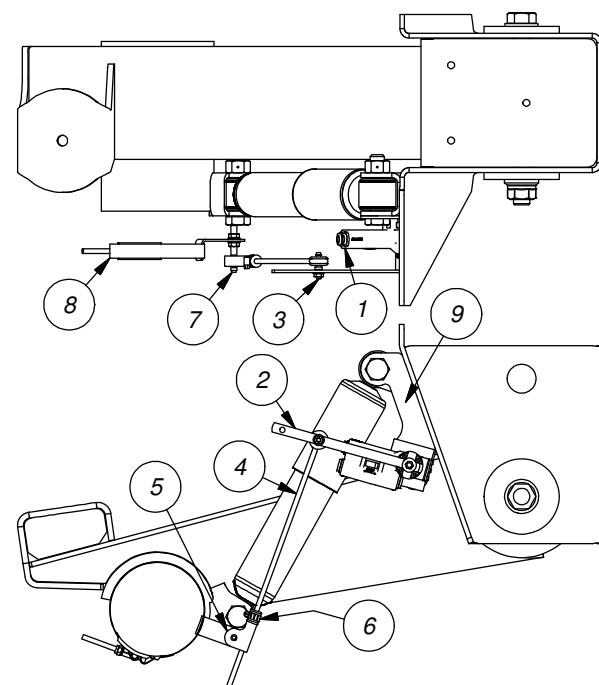
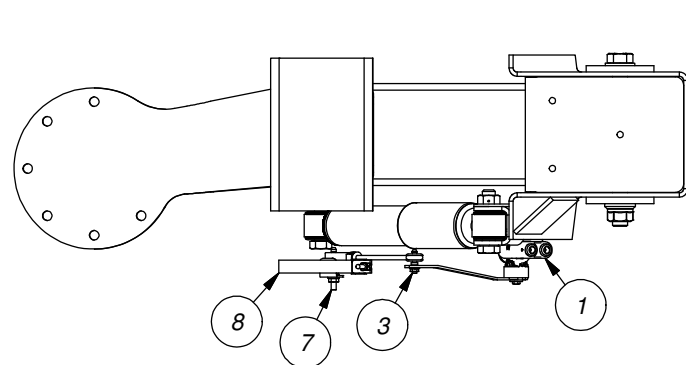

RAR-260 25K AND 30K OVERSLUNG
RAR-266 23K AND 25K OVERSLUNG

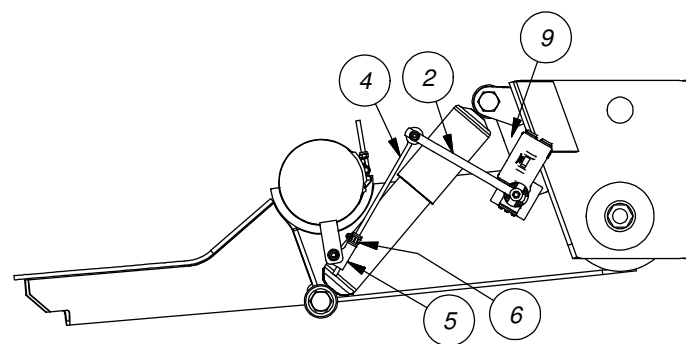

RAR-260 25K AND 30K UNDERSLUNG

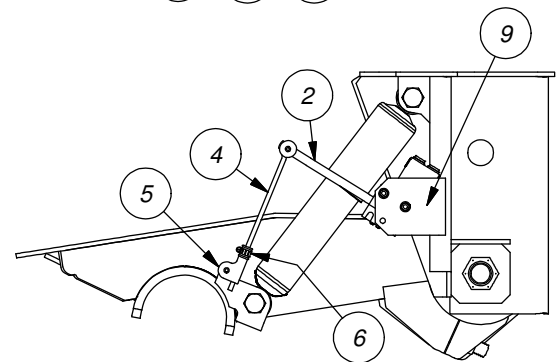
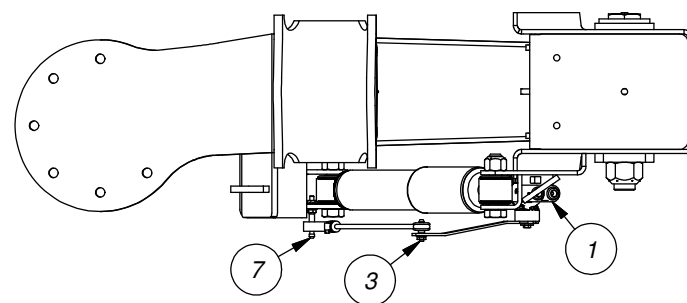
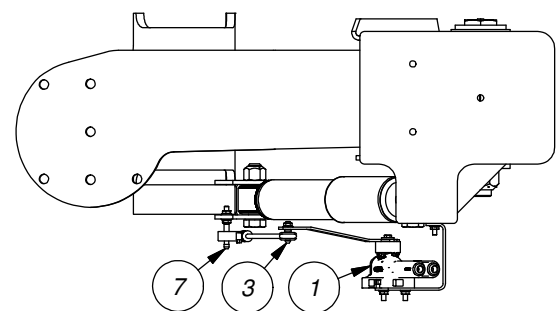

RAR-240 25K OVERSLUNG

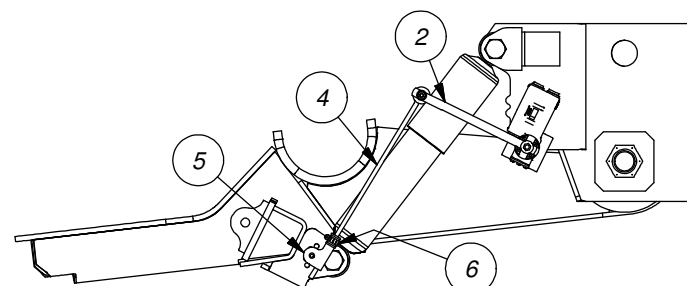

RAR-240 15K, 25K, 30K UNDERSLUNG
RAR-243 25K UNDERSLUNG

Figure 6. Troubleshooting Height Control Valve Installation

Height Control Valve - A "bad HCV" is a common misdiagnosis of the air system not working. Most problems can be traced to other parts of the system. Pinched/damaged lines or loose component fittings are often the cause of an air leak that causes the HCV to not work as it should. Repair any problems before continuing with troubleshooting.

Problem	Possible Cause	Corrective Action
Ride Height too high or too low.	<ul style="list-style-type: none"> — HCV out of adjustment or not installed correctly. 	<ul style="list-style-type: none"> — Refer to engineering drawing for ride height specifications. Check adjustment of HCV.
HCV is not receiving air or is not delivering air to the air springs.	<ul style="list-style-type: none"> — Blocked air supply line. — Air tank is not filling/reaching set pressure. — Pressure Protection Valve (PPV) not working correctly. — Pilot port is not plumbed or is plumbed incorrectly. 	<ul style="list-style-type: none"> — Verify air lines are pressurized by removing supply line at HCV. Check for pinched lines. — Verify air tank pressure with manual/in-line pressure gauge. — Check PPV operation by making sure that valve opens when system reaches the desired pressure setpoint (<i>usually greater than 70 psi</i>). — Check HCV configuration – Non-Dump; Pressure-Dump (Normally Open); Zero-Pressure Dump (Normally Closed). Reinstall, if necessary.
Air springs fill but do not exhaust.	<ul style="list-style-type: none"> — Obstructed air line. — HCV installed backwards. — Supply line installed in suspension port 	<ul style="list-style-type: none"> — Disconnect linkage and rotate actuating lever to down position (exhaust). If springs remain inflated, check for pinched/blocked lines. — Check installation. Reinstall, if necessary. — Move air supply line to HCV supply port.
Air system leaks down in a short period of time.	<ul style="list-style-type: none"> — HCV installed backwards. — Leak in air system beyond accepted standards. 	<ul style="list-style-type: none"> — Disconnect HCV linkage and rotate actuating lever to the up position (fill). If air springs do not inflate, reinstall HCV. — To find leak in the HCV area, pressurize system and spray soapy water solution onto the valve and lines. Check for bubbles (leaks): No leak found – Do not remove valve, check the rest of the system for leaks. Check that tubing cuts are straight and smooth. Re-cut and reassemble if necessary.

Warranty

The Ridewell Corporation warrants the Automatic Height and Leveling Air Control Valve manufactured by it to be free from defects in material and workmanship for a period of 1 year from the date code molded into the body.

Warranty coverage is limited to the repair/replacement of valve parts. Coverage applies only to valves that have been properly installed, maintained and operated. No warranty applies to air lines, fittings, mounting hardware, actuating arm, linkage, or axle attachments.

Ridewell reserves the right to require any valve to be returned for inspection before claim is obtained. All returns must have

transportation charges prepaid by the customer and accompanied with a complete written explanation of claimed defects and the circumstances of operational failure.

This non-transferable warranty is in lieu of all other expressed or implied warranties or representations, including any implied warranties of merchantability or fitness or any obligations on the part of Ridewell.

Ridewell will not be liable for any business interruptions, loss of profits, personal injury, any costs of travel delays or for any other special, indirect, incidental or consequential losses, costs or damages caused by Ridewell.

Notes and Cautions

This instruction uses two types of service notes:

"NOTE": Provides additional instructions or procedures to complete work tasks and make sure that the component functions properly.

CAUTION Indicates a hazardous situation or unsafe practice that, if not avoided, could result in equipment damage and serious injury.