

Extreme Air™

High Performance Height Control Valve

Features

- ◆ *Minimal deadband*
- ◆ *All push-to-connect fittings*
- ◆ *Universal mounting*
- ◆ *Quick & accurate operation*
- ◆ *Dump and non-dump configurations*
- ◆ *2-year warranty*
- ◆ *Competitively priced*

Benefits

Ridewell's high performance height control valve for trucks, trailers, buses, and recreational vehicles responds quickly to correct air pressure and return vehicle to desired ride height.

The maintenance-free valve is designed with a universal mounting to work with all applications



Extreme Air™

High Performance Height Control Valve

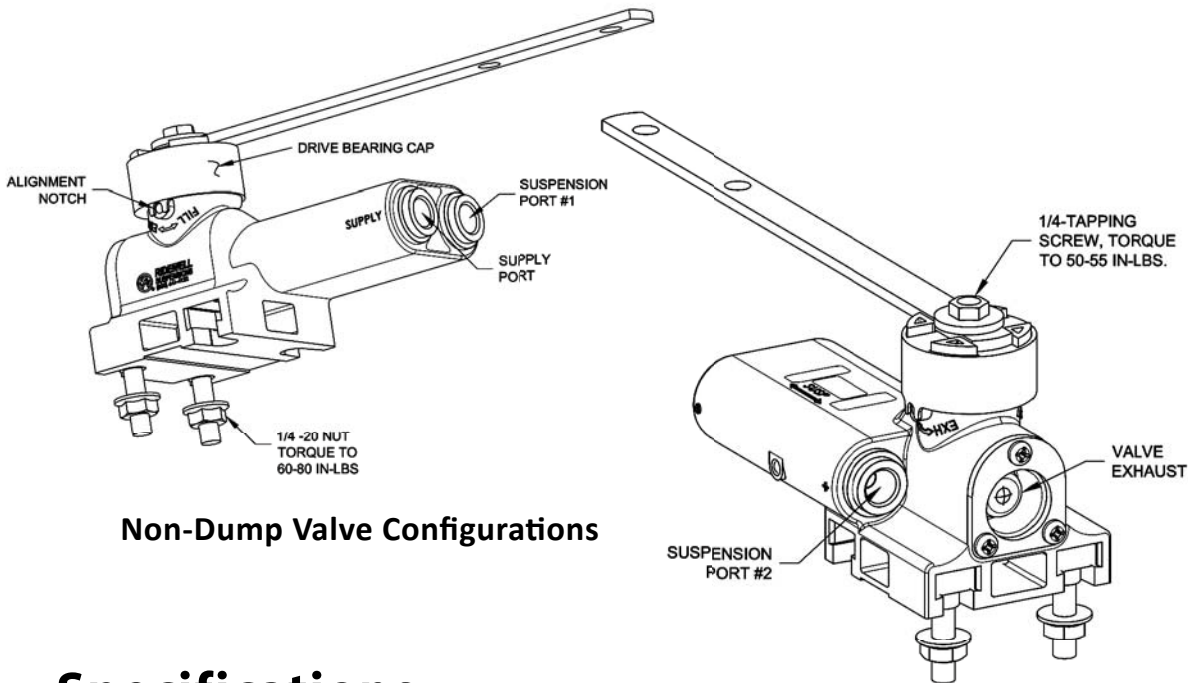

Non-Dump Valve Configurations

Specifications

Dampening	None	Exhaust Flow	7 CFM at 10 degrees
Dead Band	+ / - 1.5 degrees	Exhaust Angle Limit	Full Travel 180 degrees
Centering	+ / - 2 degrees	Dump Flow	30+ CFM (.25 flow dia.)
Fill Flow	12.5 CFM 10 degrees	Operating Pressure Max.	150 psi
Fill Flow Vehicle on Bumpers	17 CFM max.	Temperature Range	-40F to 150F
Fill Angle Limit	Full Travel	Lever Mounting	4 directions
		Base Weight (non-dump)	12.2 oz (includes lever/studs)

Dump Valve Configurations

(shown with optional offset lever)

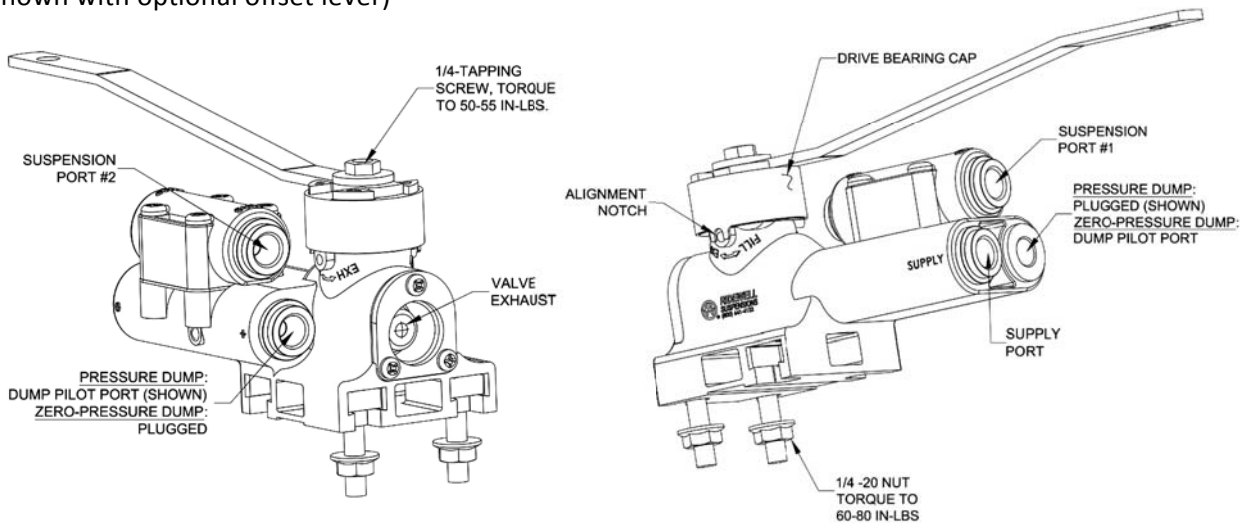

P.O. Box 4586 ♦ Springfield, Missouri 65808
www.ridewellcorp.com ♦ 800.641.4122 ♦ Fax 417.833.4560