

Bushing Assembly and Replacement Instructions for:

- RSS-233 – 13K Truck (13K Capacity)
- RSS-233T – 13K Trailer (13K Capacity)

233-13K Truck – Bushing Replacement Kit

Replacement Kit - Part No.	Pivot Hardware	Torque Values	
		foot-pound	Newton-meter
6040133	Bushing kit w/o hardware	310 ft-lb	420 N-m
6040134	Pivot Bolt (HHCS) Pivot Nut (Lock Nut)	310 ft-lb	420 N-m

CAUTION Failure to install and maintain fasteners at torque specifications could result in suspension failure and void the warranty.

Park the vehicle on a level surface. Chock wheels to keep vehicle from moving. Exhaust all air from the air system. Disassemble suspension, if necessary, to reach pivot connections.

CAUTION Failure to properly chock wheels and exhaust air system could allow vehicle/suspension movement that could result in serious injury.

Bushing Replacement Procedure – 233-13K Truck

Bushing should be replaced in the eight pivot connections at the same time (Figure 1).

1. Remove the pivot hardware by cutting/grinding away the Huck® Collar. Discard pivot hardware.
2. Remove the bushing assembly from the rod eye. Clean the rod eye of foreign debris/corrosion.
3. Apply Energy Suspensions® Formula 5 Prelube to the bore (inside) of each bushing half. NOTE: Do not substitute - urethane bushing lubricant is included with all bushing replacement kits.
4. Press bushing halves into the eye of the torque rod until halves are snug against the eye. NOTE: Mallet may be needed to install the bushing.

5. Press the bushing inner sleeve into the center opening of the installed bushing. NOTE: Mallet or bushing press will be needed to insert sleeve into installed bushing.
6. Check that installed bushing inner sleeve is flush with both sides of new bushing.
7. Install pivot hardware and torque to specifications.

8. Reassemble suspension, if necessary. Torque to specifications.
9. Check wheel toe-in setting (between 1/32" and 3/32") and adjust, if necessary.

CAUTION Failure to torque pivot hardware can result in suspension failure and void the warranty.

Notes and Cautions

This instruction uses two types of service notes:

“NOTE”: Provides additional instructions or procedures to complete tasks and make sure that the suspension functions properly.

CAUTION Indicates a hazardous situation or unsafe practice that, if not avoided, could result in equipment damage and serious injury.

Bushing Assembly

1. Apply urethane bushing lubricant to inside of each bushing half.
2. Press bushing halves into rod eye.
3. Press inner sleeve into bushing assembly.

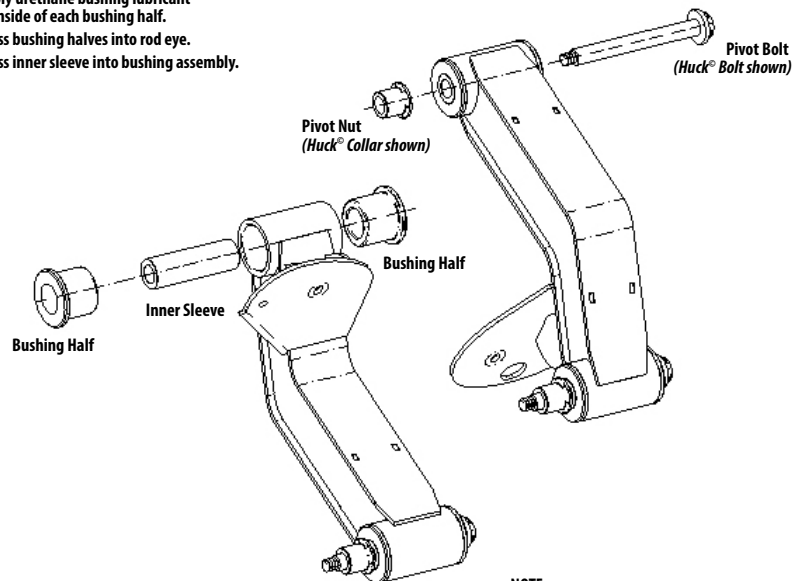

NOTE:
Bushing Replacement Kit includes traditional pivot hardware, not Huck Fasteners

RIDEWELL
SUSPENSIONS
Part No.: 9710034

Figure 1. The bushing replacement kit with hardware includes traditional hardware to replace the Huck® Fasteners used for initial assembly.

233T-13K Trailer – Bushing Replacement Kit

Bushing Replacement Kit		Torque Values	
Part Number	Pivot Hardware	foot-pound	Newton-meter
6040187	Bushing kit w/o hardware	310 ft-lb	420 N-m
6040188	Pivot Bolt (HHCS) - Pivot Nut (Locknut)	310 ft-lb	420 N-m

CAUTION Failure to install and maintain fasteners at torque specifications could result in suspension failure and void the warranty. Refer to the engineering drawing of each model for torque specifications.

Park the vehicle on a level surface. Chock wheels to keep vehicle from moving. Exhaust all air from the air system. Disassemble suspension, if necessary, to reach pivot connections.

CAUTION Failure to properly chock wheels and exhaust the air system could allow vehicle/suspension movement that could result in serious injury.

Bushing Replacement Procedure – 233T-13K Trailer

Replace eight pivot connection bushings at the same time (Fig. 2).

- Remove Huck® Collar by cutting/grinding. Take pivot connection apart. Discard pivot hardware. Discard wear washers.
NOTE: Wear washers included in all bushing replacement kits. Suspensions purchased before October 2018 do not use wear washers at the pivot connection.
- Remove bushing assembly from the rod eye and discard.
NOTE: Bushing assembly before October 2018 consists of two bushing halves and inner sleeve.
- Clean the torque rod eye of foreign debris/corrosion with a wire brush before installing new bushing assembly.
- Apply Energy Suspensions® Formula 5 Prelube to the bore (inside) of the replacement bushing. NOTE: Do not substitute - urethane bushing lubricant is included with all bushing replacement kits.
- Install (press) bushing into the eye of the torque rod.
NOTE: Mallet/press needed to install bushing.
- Press inner sleeve into the installed bushing. Center the sleeve inside the bushing so that the sleeve ends extend slightly past the bushing sides.
- Assemble the pivot connection with one wear washer on each side of the bushing. The inner sleeve of the bushing must be flush with or extend slightly past the outside of the wear washers after assembly.
NOTE: Bushing replacement kit (6040188) includes traditional pivot hardware. Wear washers included in all replacement kits.
- Torque pivot hardware to specifications (see chart).
- Reassemble suspension, if necessary. Torque to specifications (see engineering drawing).
- Check wheel toe-in setting (between 1/32" and 3/32") and adjust, if necessary.

CAUTION Failure to torque pivot hardware can result in suspension failure and void the warranty.

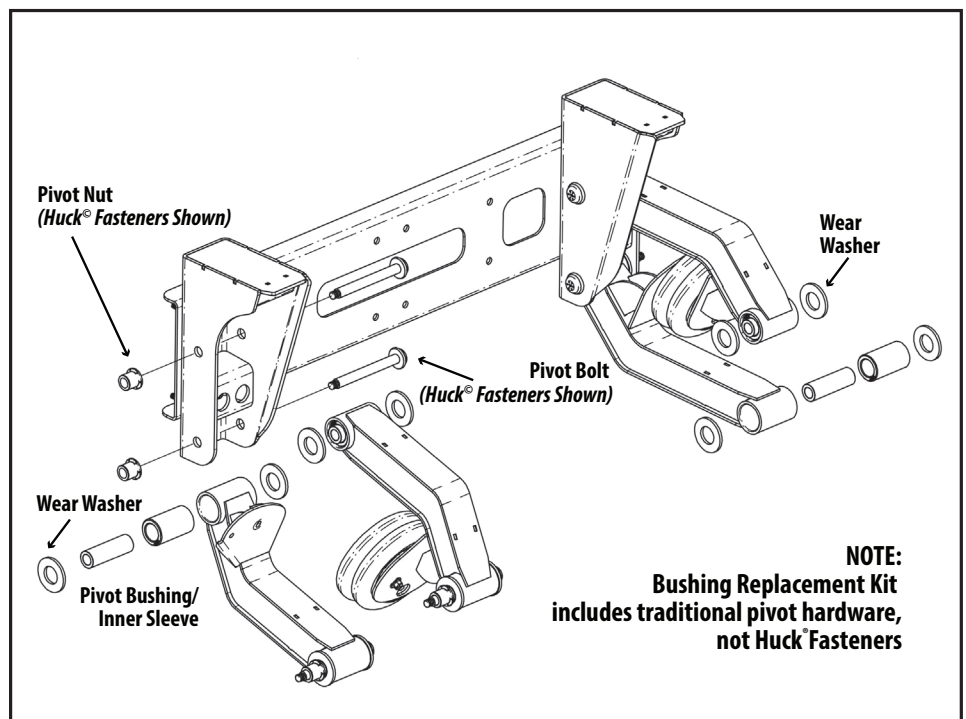

Figure 2. The bushing replacement kit with hardware includes traditional hardware to replace the Huck® Fasteners used for initial assembly.