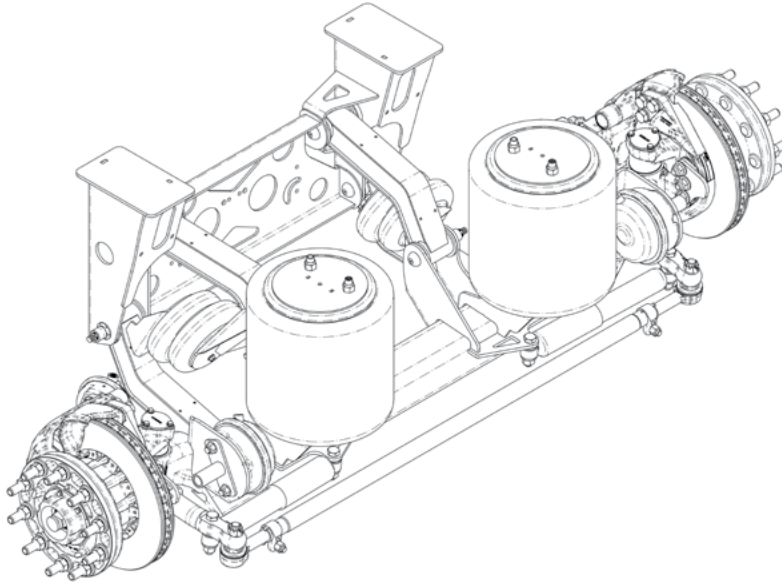


# RSS-233T - 20K Trailer

## Self-Steering Air-Ride Suspension



# Installation and Service Manual

<b>Suspension Identification</b> .....	<b>2</b>
<b>Installation</b>	
<b>Prior to Installation</b> .....	<b>3</b>
Suspension Mounting .....	4
Wheel Toe Setting .....	5
Air Control Kit – Troubleshooting .....	6
<b>Maintenance</b>	
<b>Recommended Service Intervals</b> .....	<b>7</b>
<b>Parts Illustrations</b>	
233T 20K – Drum Brakes .....	8
233T 20K – Drum Brakes with Air Spring Bridge .....	8
233T 20K – Disc Brakes .....	9
233T 20K – Disc Brakes with Air Spring Bridge .....	9
Drum Brake Axle – Standard Kingpin - Steer Lock .....	10
Disc Brake Axle – Standard Kingpin - Steer Lock .....	10
<b>Bushing Replacement/Torque Specifications</b> .....	<b>11</b>
<b>Warranty</b> .....	<b>12</b>

## SUSPENSION IDENTIFICATION

### Introduction

The Ridewell Self-Steering (RSS) 233 Suspension series is a fully integrated, auxiliary axle suspension system for truck and trailer applications.

The RSS-233T 20K Trailer Suspension System can be configured with drum or disc brake axle assemblies and with an optional steering lock. The suspension system should be configured with a drum brake axle assembly for Roll-Off Applications.

Refer to the engineering drawing for detailed information on the suspension system components and operating parameters.

Additional information on available kingpin configurations and pivot bushing replacement is found in "233\_232-Kingpin/Bushing-Parts Guide" (9710033).

### Suspension Identification Tag

A (606-) **Installation/Assembly Number** will be listed as the **Part Number** when other system components are factory installed with the suspension (Figure 1).

The **Suspension Number** and **Serial Number** on the Suspension ID Tag refer to the model and the date of manufacture of an individual suspension system.

Please refer to the suspension number/part number and serial number on the Suspension Identification Tag when contacting Ridewell for customer service, replacement parts and warranty information.

### Notes and Cautions

All work should be completed by a properly trained technician using the proper/special tools and safe work procedures.


Read through the entire Installation and Service Manual (ISM) before performing any installation or maintenance procedures.

The ISM uses two service notes to provide important safety guidelines for the suspension operation.

The service notes are defined as:

"NOTE": Provides additional instructions or procedures to complete tasks and make sure that the suspension functions properly.

**⚠ CAUTION** Indicates a hazardous situation or unsafe practice that, if not avoided, could result in equipment damage and serious injury.

 <b>RIDEWELL SUSPENSIONS</b> The Engineered Suspension Company	
PART NO:	
SUSP. NO:	
SERIAL NO:	
GROSS AXLE WEIGHT RATING CERTIFICATION IS PER THE FINAL STAGE MANUFACTURER OR ALTERER.	
THIS PRODUCT MAY BE COVERED UNDER ONE OR MORE PATENTS, ADDITIONAL PATENTS MAY BE PENDING.	
www.ridewellcorp.com	(800) 641-4122

**Figure 1.**  
**The Suspension Model (Suspension Number) and the date of manufacture (Serial Number) are listed on the Suspension Identification Tag.**

## Prior to Installation

Refer to the engineering drawing to confirm dimensional requirements and the range of ride heights available.

Installations can vary and procedures should be adapted for different vehicles, as needed.

- The Gross Axle Weight Rating (GAWR) is determined by the system component with the lowest load rating. Please consult with tire, wheel, axle and brake manufacturers before installation to determine the GAWR.
- If vehicle chassis modifications are required, consult with the vehicle manufacturer to ensure that such changes are permitted.
- Welding or altering suspension components is not permitted without the express written permission of Ridewell Suspensions.

## Self-Steering Option

Self-steering suspensions are designed to steer only in the forward direction. The suspension must be raised off the ground or locked into a non-steering configuration during reverse travel to avoid damaging the suspension.

Use caution when maneuvering in reverse with the steering lock engaged. The driver should maintain slow maneuvering speeds and avoid extreme turns.

1. Ridewell Suspensions strongly recommends the use of automated systems that raise/lock the lift-axle during reverse travel.
2. For manual operations, Ridewell recommends the installation of a visual/audible indicator to assist the driver.

**CAUTION** Failure to lift the suspension and-or engage the steering-lock during reverse travel can cause component damage and void the warranty.

## Installer Responsibilities

The installer of the suspension has the sole responsibility for proper attachment of the suspension system to the vehicle chassis.

- The installer is responsible for locating the suspension system on the vehicle to provide the proper load distribution.
- The installer must verify that vehicle crossmembers are positioned to support the suspension at the installing location.
- The installer must verify there is sufficient clearance for proper functioning of the installed auxiliary suspension – air springs; brake chambers; steering components; axle (including axle to driveline clearance); and, tires and wheels.
- It is the installer's responsibility to determine that axle spacing conforms to any applicable federal and local bridge laws.
- The installer must verify that air reservoir volume requirements are met after suspension installation. Consult the vehicle manufacturer or Federal Motor Vehicle Safety Standards (FMVSS) 121 for more information.

## Suspension Mounting

Refer to the suspension model engineering drawing for the suspension travel table; torque specifications; and, the spacing and clearance requirements for mounting the suspension.

The RSS-233T 20K Trailer Suspension is shipped fully assembled. The components must be reassembled with the proper torque applied if the system is taken apart for installation (Pg 11/Engineering Drawing).

### Weld-On Installation Procedure

Recommended locations of customer-furnished filler plates and supporting crossmembers for the hangers and air spring mounting plates are shown on the engineering drawing.

**CAUTION** The welding method used must develop a minimum weld tensile strength of 70,000 psi per AWS specifications.

1. Mark the desired location for the frame hangers and air spring mounting plates and customer-furnished filler plates on the frame.  
NOTE: For proper support, a crossmember must be located within six inches of the leading or trailing edge of the frame hanger.
2. Check the location for sufficient clearances in both the raised and lowered positions.
3. Weld customer-furnished filler plates, as needed, to crossmembers with 1/4" fillet welds down the length of the crossmember.
4. Weld customer-furnished filler plates for air spring mounting plates to frame and crossmember(s). Weld filler plates with 1/4" fillet welds down the length of crossmember.
5. Weld the hangers to the frame/filler plates with 1/4" fillet welds completely around the hangers. Stop the welds 1/2" from the corners and edges.
6. Weld the air spring mounting plates to the frame/filler plates with 3/16" fillet welds all the way around the mounting plates/bridge assembly.
7. If components have been removed for installation, reinstall as shown on engineering drawing. Torque to specifications (Page 11).
8. Install/connect the air control kit (ACK) to the suspension. Check the air system installation for leaks and proper operation of controls (Page 6).
9. Perform final assembly and inspection and check the wheel toe setting (Page 5).

### Bolt-On Installation Procedure

Grade-8 bolts, flanged locknuts or locknuts with hardened washers are supplied by the installer.

Refer to the engineering drawing for the range of available ride heights; spacing and clearance requirements; and, bolting pattern detail of the suspension.

Verify that wires, hoses or other components located within the frame rail are not affected by drilling.

**CAUTION** If recommended bolt-hole locations are not available, locate and drill bolt-holes as far apart as possible to provide the most support for the assembled suspension.

Failure to torque components to specifications can result in suspension failure and void the warranty.

### Final Assembly and Inspection

1. Verify welds on hangers and air spring mounting plates. Verify all suspension components are torqued to specifications (Pg 11/ENG DWG).
2. Install wheels and tires.  
**CAUTION** When lowering an auxiliary axle on an unloaded vehicle, pressure to the load air springs must be reduced to below 10 psi.  
Failure to reduce air pressure could cause the vehicle's axles to rise from the ground and the vehicle could roll in an unsafe manner.
3. Check that tires are inflated to recommended pressure. Check wheel hubs for proper level of lubricant recommended by the manufacturer.
4. Lift the axle to the raised position. Check the air system tubing and connections for leaks.
5. Check that wheels can rotate freely and that brakes and slack adjusters are properly adjusted.
6. Raise and lower suspension assembly (wheels and tires installed) through entire range of travel. Verify sufficient clearances for air springs, brake chambers and other components.
7. Check the vehicle's reverse travel options:
  - 7.1. Check steer lock operation.
  - 7.2. Check automated system (if installed) to make sure that suspension raises/locks wheels during reverse travel.  
**CAUTION** Failure to check reverse travel operations can result in component damage and void the suspension warranty.
8. Check wheel toe-in setting and adjust, if necessary (between 1/32" and 3/32").

## Wheel Toe Setting

Wheel toe is the relationship of the distance between the front of the tires and the distance between the rear of the tires on the same axle. When the front distance is less than the rear distance, the wheels are in a “toe-in” (positive toe) condition.

### Check Wheel Toe Setting

The correct setting for the RSS-233 suspension should be positive toe-in between 1/32” and 3/32”.

1. Deflate the air springs.
2. Lift the axle enough for tires to rotate freely. Support with jack stands to ensure axle is level.
3. Position tires to point straight ahead. Spin each tire. Use a piece of chalk to mark a line on the center tread all the way around the tire.
4. Use the centerline mark to measure the distance from the front of the tire to the frame. Measure the distance from the back of the tire to the frame.
5. Subtract the front of the tire distance from the rear distance to obtain the wheel toe setting.


### Adjust Wheel Toe

1. Loosen clamps on both ends of the tie rod. Twist the tie rod forward/backward to move the front of the tire towards or away from the frame.
2. Continue rotating the tie rod until the proper toe-in setting is achieved.
3. Torque the tie-rod clamps to 50 ft-lb (68 N-m).

### Regulate load with air spring pressure

The load capacity of the auxiliary axle is adjusted by increasing or decreasing the pressure to the air springs. By applying more air, the lift axle takes on a greater percentage of the load’s weight. The load capacity is decreased as the air pressure decreases.

Accurate readings of the load capacity can be obtained by parking a loaded vehicle over a calibrated scale and lowering the axle onto the scale. The air pressure to the air springs is manually adjusted up or down to obtain the axle load weight at various air pressures.

 **CAUTION** Do not exceed the rated load capacity of the suspension system or other components. Exceeding the capacity can cause component failure and void the warranty.



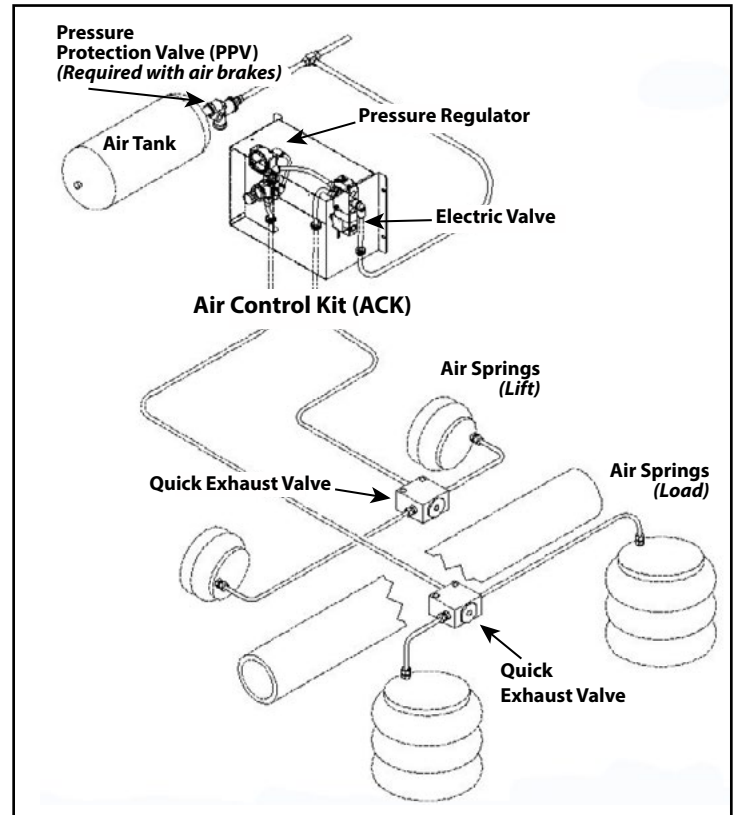
## Install air system components

Connect the load and lift air springs and an air control kit to the air system (Figure 2).

The air control kit (ACK) consists of a pressure regulator with a gauge connected to an air valve controlled by an electric switch or manual knob. The ACK allows the operator to control the air spring pressure so that the auxiliary axle can support different loads.

Ridewell has a number of manual/electric ACK configurations available. Installation will vary by the type of configuration.

**⚠ CAUTION** The installer is responsible for making sure that air system requirements comply with the appropriate Federal Motor Vehicle Safety Standards.



**Figure 2.**  
**Example of Air Control Kit (ACK) installation**

### AIR CONTROL KIT – TROUBLESHOOTING

Problem	Possible Cause	Solution
<b>Air springs fill but do not exhaust.</b>	<ul style="list-style-type: none"> <li>___ Obstructed air line.</li> <li>___ Faulty controls wiring.</li> <li>___ Manual override pushed in</li> </ul>	<ul style="list-style-type: none"> <li>___ Check for pinched/blocked lines.</li> <li>___ Check wiring with voltmeter and correct.</li> <li>___ Release manual override.</li> </ul>
<b>Air system leaks down after a short period of time.</b>	<ul style="list-style-type: none"> <li>___ Leak in air system beyond accepted standards.</li> </ul>	<ul style="list-style-type: none"> <li>___ Pressurize system. Spray soap water solution onto tubing, valves and fittings. Check for bubbles (leaks). Note: Some valves leak at an acceptable rate.</li> <li>___ Check that tubing cuts are straight and smooth. Re-cut and reassemble fitting joints, if necessary.</li> </ul>
<b>Auxiliary unit will not stay up</b>	<ul style="list-style-type: none"> <li>___ Loose Air Fittings/ Damaged Air Lines.</li> <li>___ Air lines to lift and load air springs are reversed.</li> <li>___ Damaged/Worn Air Springs.</li> </ul>	<ul style="list-style-type: none"> <li>___ Check and retighten fittings. Repair or replace component, as necessary.</li> <li>___ Check installation. Air line from regulator goes to (load) air springs.</li> <li>___ Replace if worn or damaged.</li> </ul>
<b>Auxiliary unit not getting correct lift</b>	<ul style="list-style-type: none"> <li>___ Air lines to lift and load air springs are reversed.</li> <li>___ Lift air springs do not have proper air pressure.</li> <li>___ Interference with driveline or other chassis components.</li> <li>___ Air control system not installed correctly.</li> </ul>	<ul style="list-style-type: none"> <li>___ Check installation. Air line from regulator goes to (load) air springs.</li> <li>___ Check for loose fittings/damaged lines. Verify tank pressure with gauge.</li> <li>___ Visually inspect unit operation for clearance. Retighten loose fasteners.</li> <li>___ Check installation; refer to OEM installation procedures.</li> </ul>

**Recommended Service Intervals**

Ridewell Suspensions recommends these minimum service intervals for standard duty, on-highway usage applications. More frequent intervals are recommended for heavier duty applications.

**Daily/Pre-Trip Inspections**

- \_\_\_ Visually inspect suspension structure for signs of damage or excessive wear.
- \_\_\_ Check for loose or missing bolts/nuts.  
Check for irregular movement in suspension components.
- \_\_\_ Check tires for proper inflation, damage or excessive wear.
- \_\_\_ Check wheel-ends for obvious signs of lubricant leakage. Check for missing components.
- \_\_\_ Make sure air controls are operating properly.  
Drain all moisture from air reservoirs.

**First 6,000 miles of use**

- \_\_\_ Torque all suspension bolts/nuts to specifications (Page 11/Engineering Drawing).

**Every 12,000 miles of use**

- \_\_\_ Lubricate Brake Cam and Slack Adjuster.
- \_\_\_ Inspect kingpins and upper/lower kingpin bushings for wear. Grease thrust bearings.
- \_\_\_ Inspect steering damper for damage/wear.
- \_\_\_ Inspect air springs for any damage/excessive wear. Torque air spring bolts/nuts to specifications (Page 11/Engineering Drawing).
- \_\_\_ Check air system for leaks.

**First 50,000 miles of use**

- \_\_\_ Torque all suspension bolts/nuts to specifications (Page 11/Engineering Drawing).
- \_\_\_ Check wheel ends for excessive play.
- \_\_\_ Check pivot bushings for wear.
- \_\_\_ Check operation of (reverse) steering lock (if equipped).
- \_\_\_ Verify operation of manual/automatic lift-in-reverse control (if equipped).
- \_\_\_ Inspect tie-rod and the tie-rod ends for excessive damage/wear. Lubricate tie-rod ends. Check that tie-rod boot is in place and completely over the end of the tie-rod. Replace entire tie-rod end if boot is damaged.

**Annual/100,000 Miles Inspection**

- \_\_\_ Inspect pivot connections for worn bushings/wear washers. Replace if necessary. Torque all hardware to spec. (Pg 11/ENG Drawing).
- \_\_\_ Check hanger and air spring mounting plate connections to frame.

**Check lubrication level in wheel ends:**

- \_\_\_ Oil-Filled Wheel Ends:  
Refill/Replace lubricant as needed (TMC RP 631-“100K/Annual Inspection”).
- \_\_\_ Check air system for leaks.
- \_\_\_ Test air tank pressure protection valve (PPV) if equipped.
- \_\_\_ Check brake chambers/brakes for damage and proper function.

**CAUTION** Failure to exhaust all pressure from the air system before vehicle work can cause serious injury.

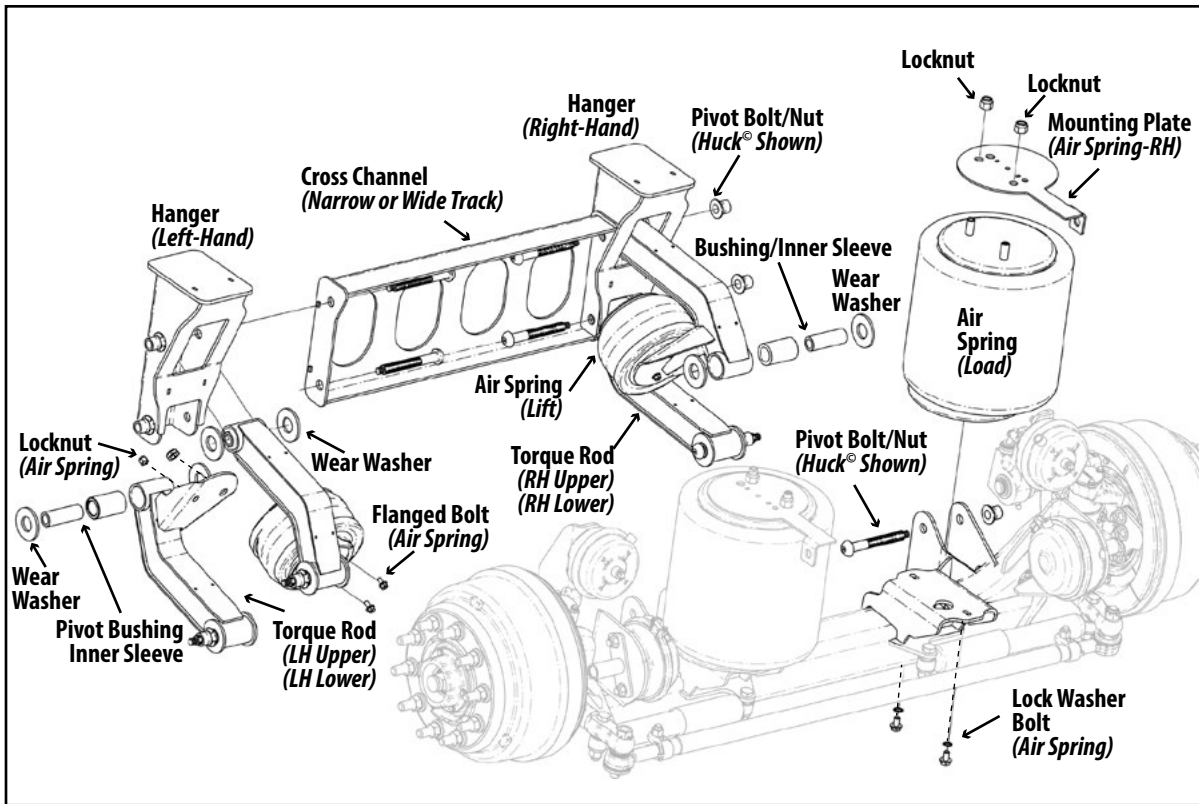
**CAUTION** Failure to torque bolts/nuts of suspension components to specifications can result in suspension failure and void the warranty.

**Refer to these Technology & Maintenance Council (TMC) Recommended Procedures for additional information:**

RP 609	Self-Adjusting/Manual Brake Adjuster Removal, Installation and Maintenance
RP 618	Wheel Bearing Adjustment Procedure
RP 619	Air System Inspection Procedure
RP 622	Wheel Seal and Bearing Maintenance
RP 631	Wheel End Lubrication Procedures
RP 643	Air Ride Suspension Maintenance Guidelines
RP 645	Tie-Rod End Inspection/Maintenance
RP 651	Steer Axle Maintenance Guidelines

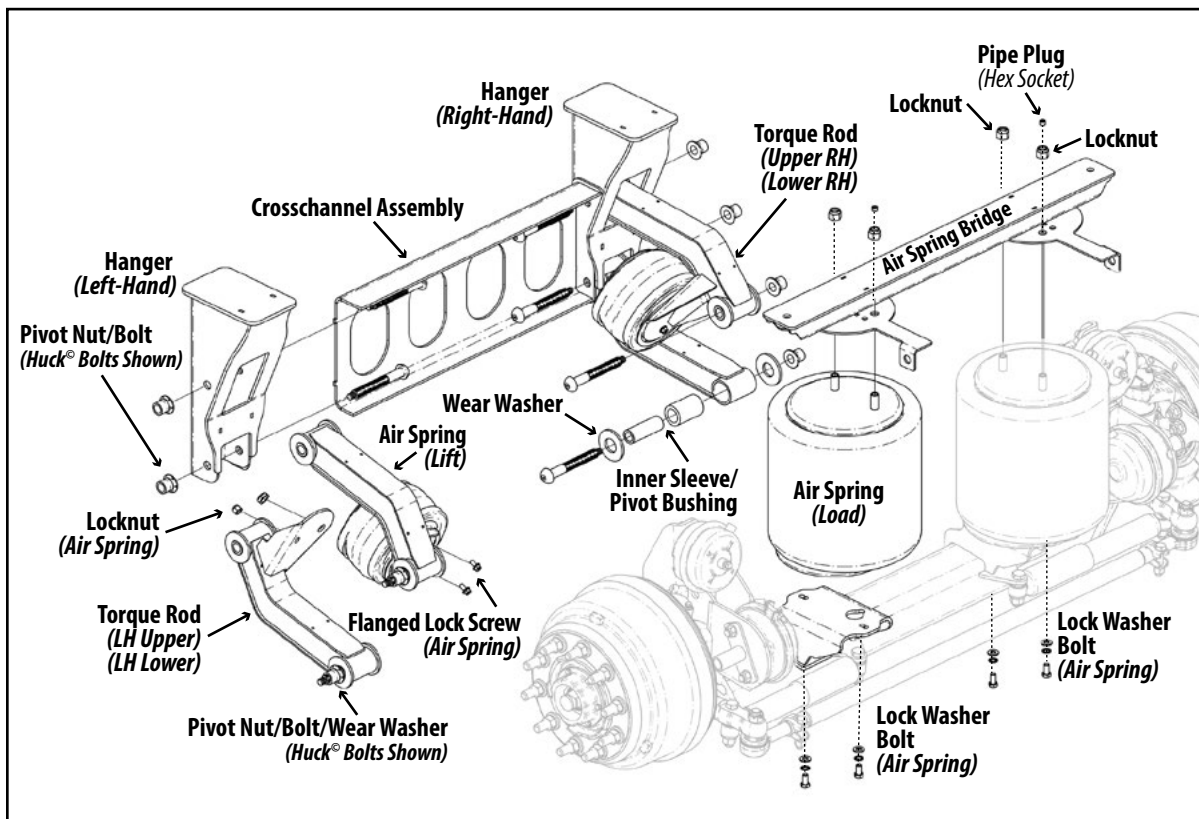
**AVAILABLE WHEEL-END LUBRICANTS**

Lubricant Type	P/N	Item Description
Mineral Oil	<b>380008G</b>	(CITGO) MP GearOil 631310001-80W-90
Synthetic Oil	<b>1980006</b>	(SHELL) Synthetic API GI-5 75W-90 Oil
Synthetic Hard-Pack Grease	<b>1980007</b>	(CITGO) Synthetic Grease



**Figure 3.**  
**233T 20K**  
**Trailer with**  
**Drum Brakes**

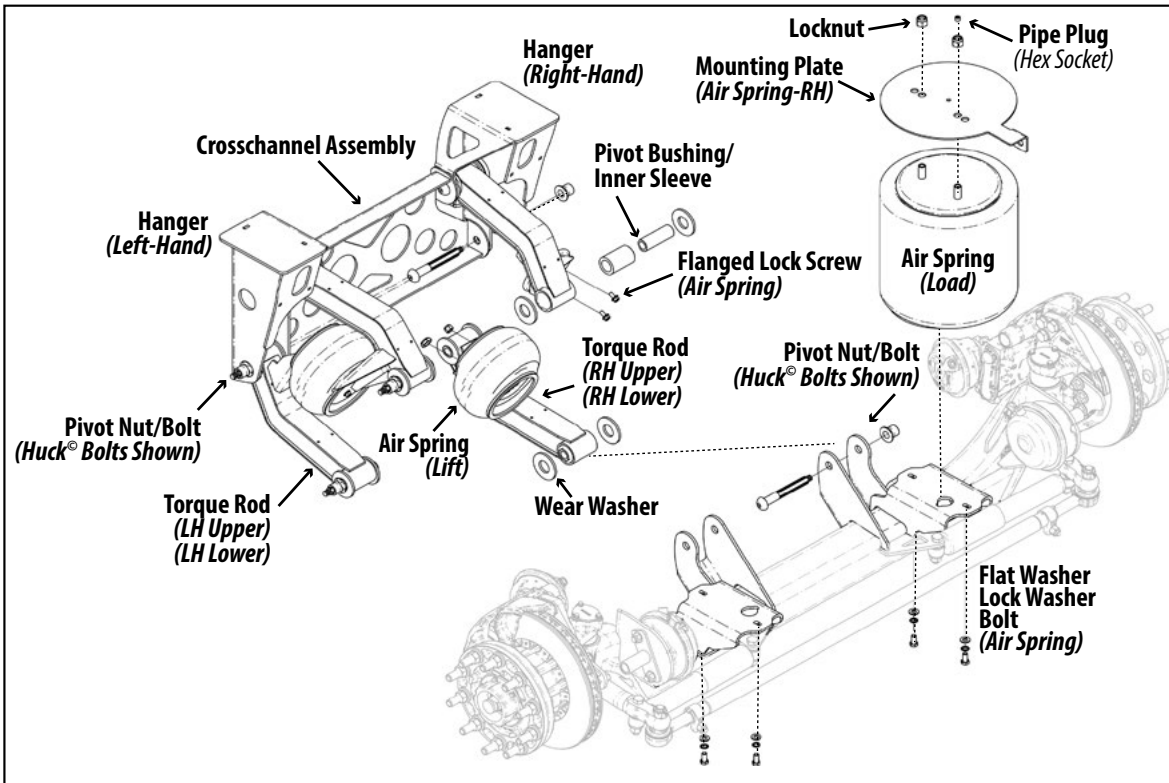
Refer to the Narrow- or Wide-Track Steer Lock (S) version of the suspension model engineering drawing for the individual component part number.



**Figure 4.**  
**233T 20K**  
**Trailer with**  
**Drum Brakes**  
**and Air Spring**  
**Bridge Assembly**

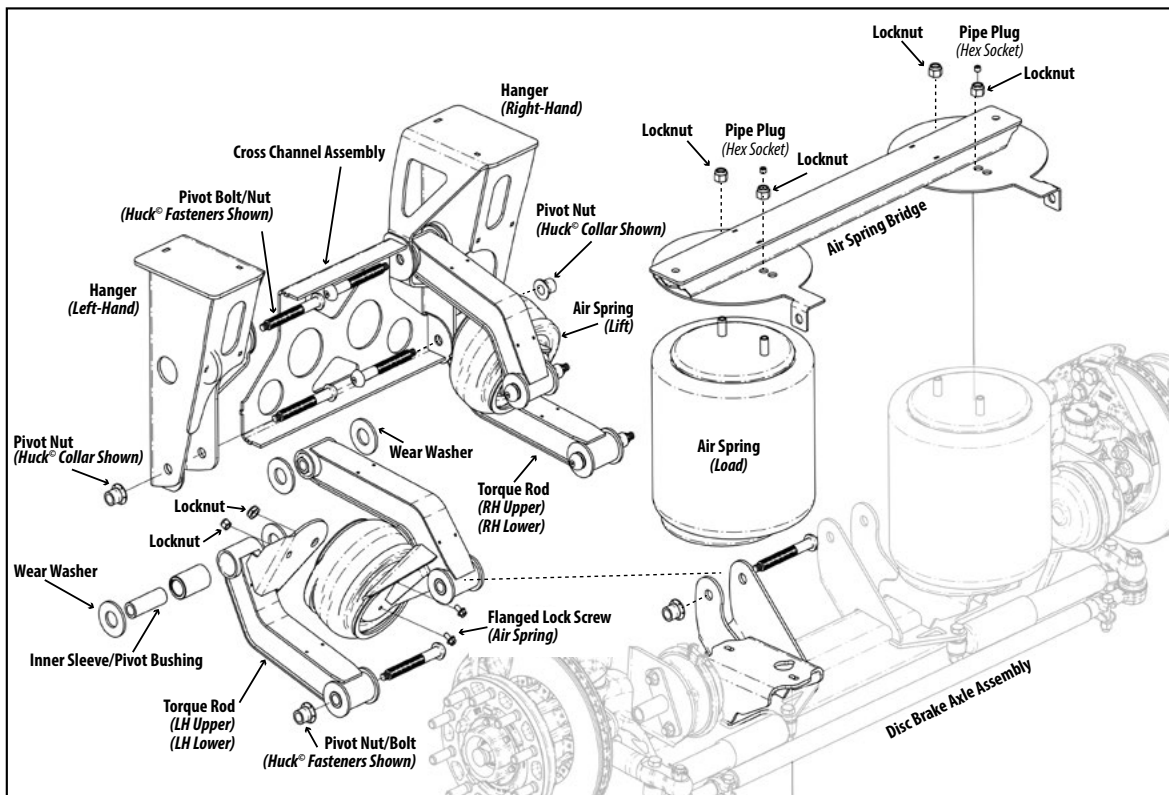
Refer to the Narrow- or Wide-Track Steer Lock (S) version of the suspension model engineering drawing for the individual component part number.





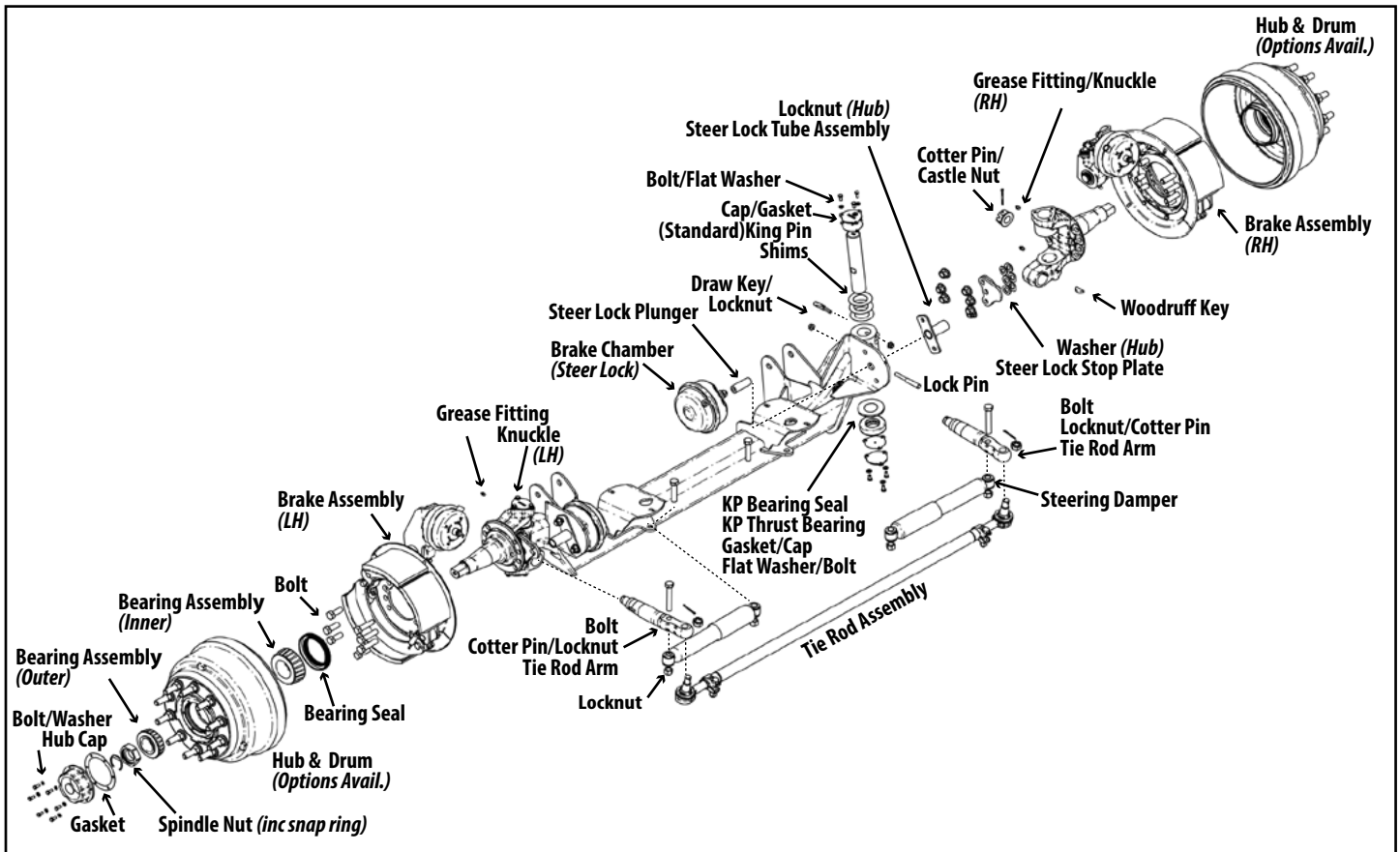
**Figure 5.**  
233T 20K Trailer  
with Disc Brakes

Refer to the Narrow- or Wide-Track Steer Lock (S) version of the suspension model engineering drawing for the individual component part number.

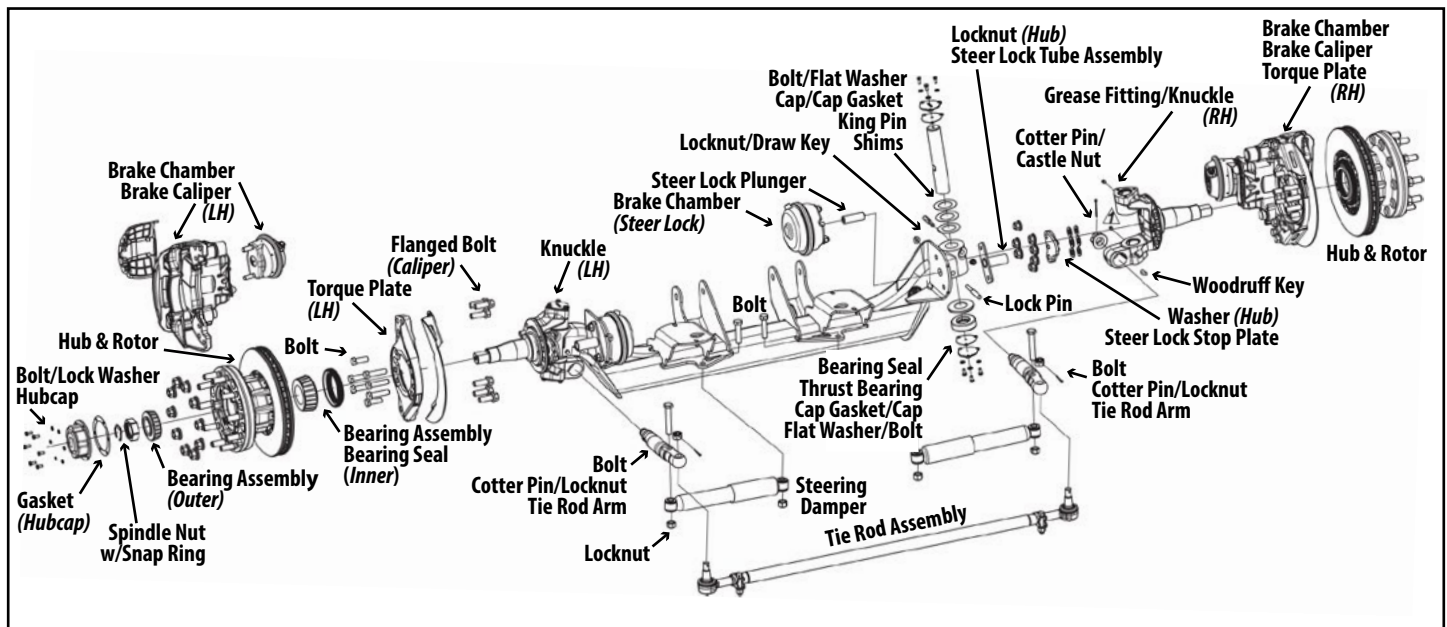


**Figure 6.**  
233T 20K Trailer  
with Disc Brakes  
and Air Spring  
Bridge Assembly

Refer to the Narrow- or Wide-Track Steer Lock (S) version of the suspension model engineering drawing for the individual component part number.



**Figure 7.**  
**233T 20K Trailer – Drum Brake Axle Assembly-Standard Kingpin with Steer Lock.**  
 Refer to the Steer Lock (S) version of the engineering drawing for the component part number.



**Figure 8.**  
**233T 20K Trailer – Disc Brake Axle Assembly-Standard Kingpin with Steer Lock.**  
 Refer to the Steer Lock (S) version of the engineering drawing for the component part number.

## 233T 20K TRAILER SUSPENSION – BUSHING REPLACEMENT/TORQUE SPECIFICATIONS

Part Number (Component)	Item Description	Size	Torque Values	
			foot-pound	Newton-meter
6040161 - Bushing Kit	Pivot Bolt/Nut (HHCS/Locknut)	7/8"-14NC	500 ft-lb	678 N-m
6040160 - Bushing Kit	No Pivot Hardware	NA	500 ft-lb	678 N-m
Fasteners	Locknut - (Air Spring)	1/2"-20NF	25 ft-lb	35 N-m
	Locknut - (Air Spring)	3/4"-16NF	50 ft-lb	68 N-m
	Bolt - (Air Spring)	1/2"-13NC	50 ft-lb	68 N-m
	Locknut - (Tie Rod/Steering Damper)	3/4"-10NC	160 ft-lb	217 N-m
	Locknut - (Crosschannel)	5/8"-11NC	160 ft-lb	217 N-m

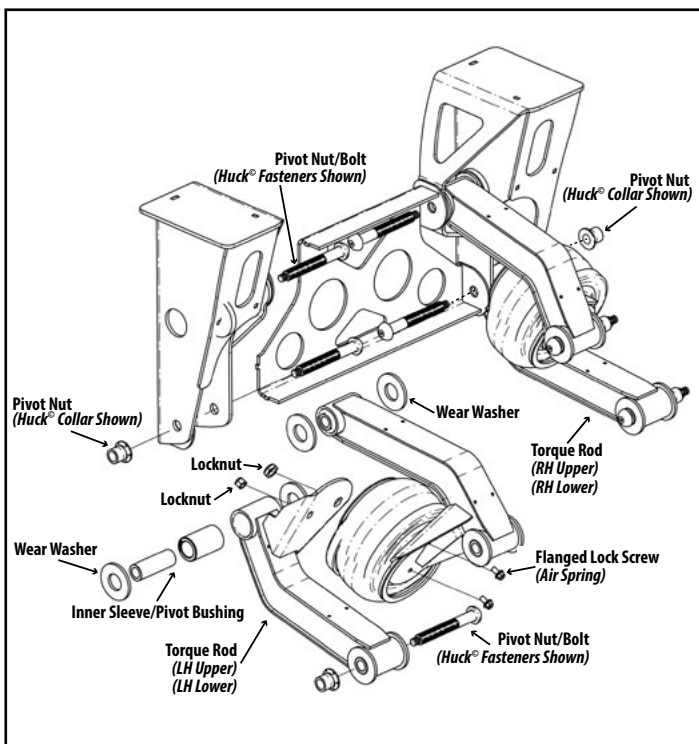
Torque values reflect a lubricated thread condition (Nuts are pre-lubed). Do not overtorque.

**CAUTION** Suspension is shipped with minimal torque applied to fasteners. All fasteners must be re-torqued after first 6,000 miles of operation. Failure to install and maintain fasteners at torque specifications could result in suspension failure and void the warranty.

Park the vehicle on a level surface. Chock wheels to keep vehicle from moving.

Exhaust all the air from the air system. Disassemble suspension, if needed, to reach the pivot connections.

**CAUTION** Failure to properly chock wheels and exhaust the air system could allow vehicle movement that could result in serious injury.



**Figure 9.**  
Traditional hardware and wear washers for eight pivot connections included in bushing kit.

1. Remove Huck® Collar by cutting/grinding (Fig 9). Take pivot connection apart. Discard pivot hardware. Discard wear washers.  
NOTE: Wear washers included in all bushing replacement kits.
2. Remove bushing assembly from the torque rod and discard. Clean the rod eye of any foreign debris or corrosion.
3. Apply Energy Suspensions® Formula 5 Prelube to the bore (inside) of new bushings.  
NOTE: Do not substitute - special urethane bushing lubricant included with all bushing kits.
4. Install bushing in the eye of the torque rod.  
NOTE: Mallet/press may be needed to install new bushing and sleeve.
5. Press inner sleeve into the installed bushing. Center the sleeve inside the bushing so that both ends extend slightly past the sides of the bushing.
6. Assemble the pivot connection with one wear washer on each side of the bushing (Figure 2). The inner sleeve of the bushing must be flush with or extend slightly past the outside of the wear washers after assembly.
7. Torque pivot nut to specifications (500 ft-lb - 678 N-m).
8. Reassemble suspension components, if necessary. Tighten components to specifications (Chart/Engineering Drawing).
9. Check wheel toe-in setting (between 1/32" and 3/32") and adjust, if necessary.

**CAUTION** Failure to torque pivot hardware can result in suspension failure and void the warranty.

### **Terms and coverage in this warranty apply only to the United States and Canada.**

Ridewell Suspensions warrants the suspension systems manufactured by it to be free of defects in material and workmanship. Warranty coverage applies only to suspensions that have been properly installed, maintained and operated within the rated capacity and recommended application of the suspension. The responsibility for warranty coverage is limited to the repair/replacement of suspension parts. The liability for coverage of purchased components is limited to the original warranty coverage extended by the manufacturer of the purchased part.

All work under warranty must have prior written approval from the Ridewell warranty department. Ridewell has the sole discretion and authority to approve or deny a claim and authorize the repair or replacement of suspension parts. All parts must be held until the warranty claim is closed.

Parts that need to be returned for warranty evaluation will be issued a Returned Materials Authorization (RMA). Parts must be returned to Ridewell with the transportation charges prepaid. The transportation charges will be reimbursed if the warranty claim is approved.

This non-transferable warranty is in lieu of all other expressed or implied warranties or representations, including any implied warranties of merchantability or fitness or any obligations on the part of Ridewell. Ridewell will not be liable for any business interruptions, loss of profits, personal injury, any costs of travel delays or for any other special, indirect, incidental or consequential losses, costs or damages.

**Contact the Ridewell Warranty Dept. at 417.833.4565 - Ext. 135, for complete warranty information.**