

RSS-236 13.5K Truck

Self-Steer Air-Ride Suspension System *Customer-Supplied I-Beam Axle*

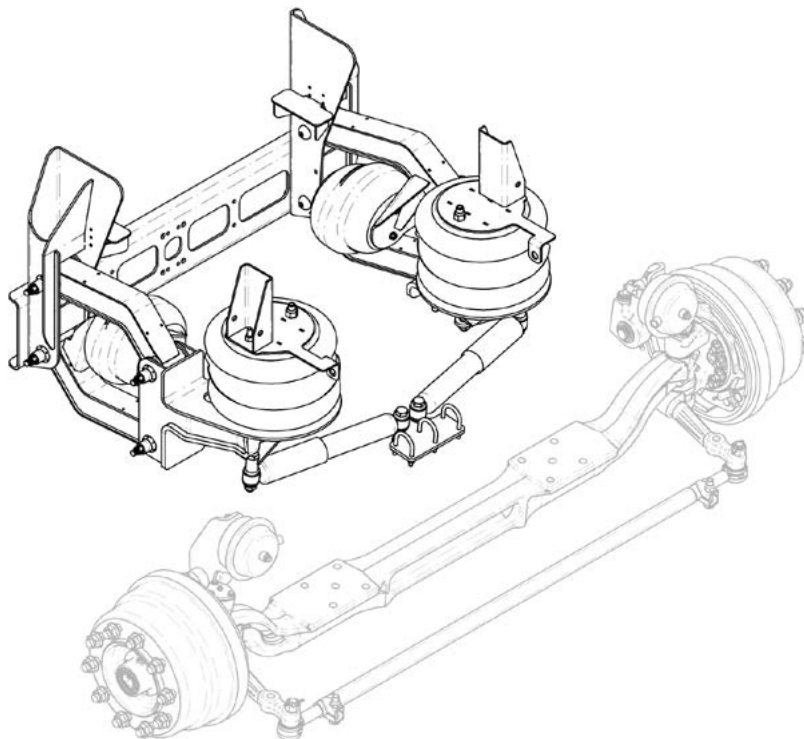

Installation and Service Manual

Suspension Identification	2
Prior to Installation	2
Suspension Mounting	3
Air Control Kit (ACK) Components - Lifiable Axle.....	4
Maintenance	
Recommended Service Intervals	5
Suspension Components–Single A/SPG mounting stud	
Suspension Components–Dual A/SPG mounting stud	6
Bushing Replacement/Torque Specifications	7
Warranty	8





PART NO:

SUSP. NO:

SERIAL NO:

GROSS AXLE WEIGHT RATING CERTIFICATION IS PER THE FINAL STAGE MANUFACTURER OR ALTERER.

THIS PRODUCT MAY BE COVERED UNDER ONE OR MORE PATENTS, ADDITIONAL PATENTS MAY BE PENDING.

www.ridewellcorp.com

(800) 641-4122

The Ridewell Self-Steering 2361000 Truck Suspension provides a liftable suspension system for integration with a customer-supplied I-Beam Axle.

Suspension Identification Tag

The **Part Number** is listed as 606- Installation/ Assembly Number when other components are factory installed with the suspension.

The **Suspension Number** and **Serial Number** refer to the suspension model and date of manufacture.

Refer to the suspension number/part number and serial number when contacting Ridewell for customer service, replacement parts and warranty information.

Notes and Cautions

All work should be completed by a trained technician using proper/special tools and safe work procedures.

Read through the entire Installation and Service Manual (ISM) before performing any procedures.

The ISM uses service notes to provide important safety guidelines. The two service notes are defined as:

“NOTE:” Provides additional instructions or procedures to complete tasks and make sure that the suspension functions properly.

⚠ CAUTION Indicates a hazardous situation or unsafe practice that, if not avoided, could result in equipment damage and serious injury.

Prior to Installation

Refer to the suspension model engineering drawing for detailed information on dimensional requirements and suspension system operating parameters.

- The Gross Axle Weight Rating (GAWR) is determined by the system component with the lowest load rating. Please consult with the tire, wheel, axle and brake manufacturers before installation to determine the GAWR.
- If vehicle chassis modifications are required, consult with the vehicle manufacturer to ensure that such changes are permitted.
- Welding or altering of suspension components is not permitted without the express written permission of Ridewell Suspensions.

Installer Responsibilities

The installer of the suspension has the sole responsibility for proper attachment of the suspension system to the vehicle chassis.

- The installer is responsible for locating the suspension system on the vehicle to provide the proper load distribution.
- The installer must verify that vehicle crossmembers are positioned to support the suspension at the installing location.
- The installer must verify there is sufficient clearance for proper functioning of the installed auxiliary suspension – air springs; brake chambers; steering components; axle (including axle to drive-line clearance); and, tires and wheels.
- It is the installer’s responsibility to determine that axle spacing conforms to any applicable federal and local bridge laws.
- The installer must verify that air reservoir volume requirements are met after suspension installation. Consult the vehicle manufacturer or Federal Motor Vehicle Safety Standards (FMVSS) 121 for more information.

Self-Steering Option

Self-steering suspensions are designed to steer in the forward direction only.

The suspension should be raised off the ground or locked into a non-steering configuration during reverse travel to avoid damage.

Ridewell Suspensions strongly recommends the use of automated systems that raise/lock the lift-axle during reverse travel. For manual operations, Ridewell recommends the installation of a visual/audible indicator to assist the driver.

⚠ CAUTION Failure to lift the suspension and-or engage the steering-lock during reverse travel may cause component damage and void the warranty.

Suspension Mounting

Refer to the suspension model engineering drawing for the suspension travel table; torque specifications; and, the spacing and clearance requirements for mounting. NOTE: Suspension includes the steering damper kit (6030007) and mounting hardware for one I-Beam axle (customer-supplied).

The suspension system is shipped fully assembled at a preset ride height for mounting (Fig 1). Adjust ride height by installing a 1" or 2" Air Spring Spacer Kit.

CAUTION The frame hanger locator flanges must be relocated after air spring spacer installation.

Bolt-On Installation Procedure

Grade 8 bolts and flanged locknuts or locknuts with hardened washers are required for installation.

1. Place suspension (with filler plates/air spring mounting spacers) in the desired location.
NOTE: Frame crossmember must be located within six inches of hanger leading or trailing edge.
2. Verify location provides adequate clearance for suspension components. Make sure top of hangers and air spring mounting plates are parallel to the chassis frame to maintain proper caster angle.
3. Hangers/air spring mounting plates should be perpendicular to chassis frame and aligned with each other. Clamp the hangers, mounting plates and any spacer/filler plates firmly in place.
4. Refer to suspension model engineering drawing for hanger/air spring mounting plate bolt-hole locations.
CAUTION If the recommended bolt-hole locations are not available, locate and drill bolt-holes as far apart as possible to provide the most support for the assembled suspension.
Check to make sure that wires, hoses or other components located within the frame rail are not affected by drilling.
5. Center punch and drill bolt holes in each hanger. Center punch and drill bolt holes in each air spring mounting bracket.
Bolt hangers and air spring brackets to the frame.
6. Axle installation procedure:
Match axle drill-holes to the load beam assembly (LBA). Make sure that the axle is correctly centered on vehicle chassis. Clamp into place.
7. Attach axle to the load beam assemblies using 3/4" Hex Head Cap Screw (HHCS), flat washers and locknuts. Torque to specifications.
CAUTION The axle turn-stop bolts may need to be adjusted to restrict the turn angle and prevent interference with other suspension components.
8. Install/connect the air control kit to the suspension air system (Page 4). Check the entire vehicle air system after installation for leaks.

Regulate load with air spring pressure

The load capacity of the auxiliary axle is adjusted by increasing or decreasing the pressure to the air springs. By applying more air, the lift axle takes on a greater percentage of the load's weight. The load capacity is decreased as the air pressure decreases.

Accurate readings of the load capacity can be obtained by parking a loaded vehicle over a calibrated scale and lowering the axle onto the scale. The airspring pressure is manually adjusted up or down to obtain the axle load weight.

CAUTION Do not exceed rated load capacity of suspension system or components. Exceeding capacity can cause component failure and void the warranty.

9. Verify all suspension component bolts/nuts are torqued to specifications (Page 7).
10. Raise and lower complete suspension assembly (wheels and tires installed) through entire range of travel to verify sufficient clearance for air springs, brake chambers and other installed components.
11. Check lift-in-reverse automated system (if installed) to make sure the suspension raises/locks wheels during reverse travel.

CAUTION Failure to torque bolts/nuts of suspension components to specifications can result in failure of the suspension and void the warranty.

CAUTION Do not lower the auxiliary axle while the vehicle is moving above 10 mph.

CAUTION Failure to check reverse travel operations can result in component damage and void the warranty.

Figure 1.
RSS-2361000 w/ dual air spring mounting stud

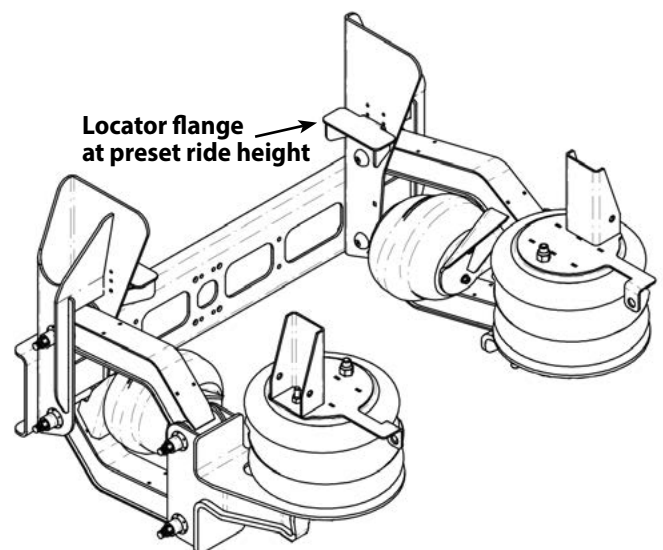

Air Control Kit (ACK) Components - Lifiable Axle

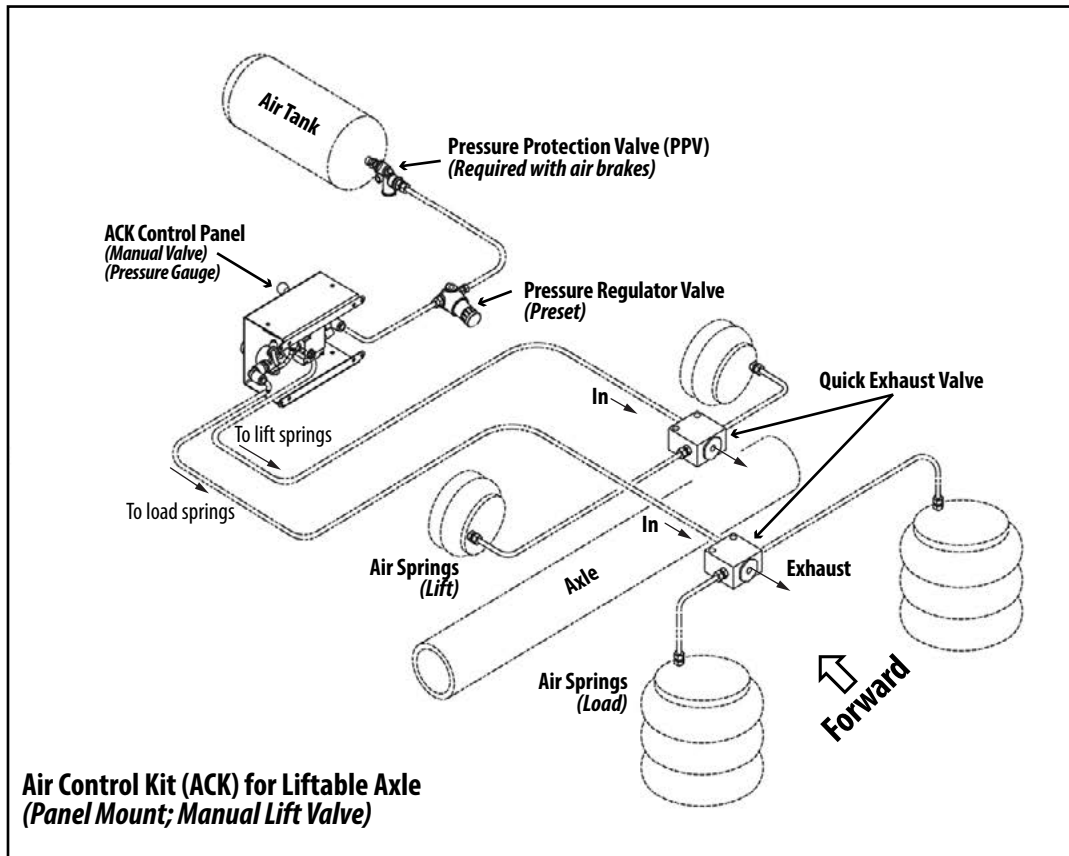

The air control kit consists of a pressure regulator with a gauge; connected to an air valve that is operator-controlled by a manual knob or by an electric switch.

The operator uses the air control kit to control the pressure to the air springs to support different loads.

Contact Ridewell Customer Service for the various manual/electric ACK configurations available. Installation will vary by ACK configuration.

CAUTION The installer is responsible for ensuring air system requirements comply with the appropriate Federal Motor Vehicle Safety Standards.

Air Control Kit – Troubleshooting

Problem	Possible Cause	Solution
Air springs fill but do not exhaust.	<ul style="list-style-type: none"> — Obstructed air line. — Faulty controls wiring. — — Manual override pushed in. 	<ul style="list-style-type: none"> — Check for pinched/blocked lines. — Check controls wiring with voltmeter. Correct wiring/installation. — Release manual override.
Air system leaks down after a short period of time.	<ul style="list-style-type: none"> — Leak in air system beyond accepted standards. <p>NOTE: Some valves will leak at an acceptable rate.</p>	<ul style="list-style-type: none"> — Pressurize system. Spray soapy water solution onto the tubing, valves and fittings. Check for bubbles (leaks). — Check that tubing cuts are straight and smooth. Re-cut and reassemble fitting joints, if necessary.
Auxiliary unit will not stay up	<ul style="list-style-type: none"> — Loose air fitting connection/Damaged air lines. — Air lines to lift and load air springs are reversed. — Damaged or worn air springs. 	<ul style="list-style-type: none"> — Check and retighten fittings. Repair or replace component, as necessary. — Check installation. Air line from regulator goes to (load) air springs. — Replace air spring if worn or damaged.
Auxiliary unit not achieving correct lift	<ul style="list-style-type: none"> — Air lines to lift and load air springs are reversed. — Lift air springs do not have proper air pressure. — Interference with driveline/other chassis components. — Air control system not installed correctly. 	<ul style="list-style-type: none"> — Check installation. Air line from regulator goes to (load) air springs. — Check for loose fittings or worn/damaged lines. Verify air tank pressure with gauge. — Visually inspect auxiliary unit operation for proper clearance. Retighten any loose fasteners. — Check air control kit installation; refer to OEM installation procedures.

Recommended Service Intervals

Ridewell Suspensions recommends these minimum service intervals for standard duty, on-highway usage applications. More frequent intervals are recommended for heavier duty applications.

Refer to these Technology & Maintenance Council (TMC) Recommended Procedures for additional information:

RP 609	Self-Adjusting/Manual Brake Adjuster Removal, Installation and Maintenance
RP 618	Wheel Bearing Adjustment Procedure
RP 619	Air System Inspection Procedure
RP 622	Wheel Seal and Bearing Maintenance
RP 631	Wheel End Lubrication Procedures
RP 643	Air Ride Suspension Maintenance Guidelines
RP 645	Tie-Rod End Inspection/Maintenance
RP 651	Steer Axle Maintenance Guidelines

Daily/Pre-Trip Inspections

- ___ Visually inspect suspension structure for signs of damage or excessive wear.
- ___ Check for loose or missing bolts/nuts. Check for irregular movement in suspension components.
- ___ Check tires for proper inflation, damage or excessive wear.
- ___ Check wheel-ends for obvious signs of lubricant leakage. Check for missing components.
- ___ Make sure air controls are operating properly. Drain all moisture from air reservoirs.

First 6,000 miles of use

- ___ Torque all suspension bolts/nuts to specifications (Page 7/Engineering Drawing).

Every 12,000 miles of use

- ___ Lubricate Brake Cam and Slack Adjuster.
- ___ Inspect steering damper for damage/wear.
- ___ Inspect the lift and load air springs for any damage or excessive wear. Torque the air spring bolts/nuts to specifications (Page 7/Engineering Drawing).
- ___ Check air system for leaks.

First 50,000 miles of use

- ___ Torque all suspension bolts/nuts to specifications (Page 7/Engineering Drawing).
- ___ Check wheel ends for excessive play.
- ___ Check pivot bushings for wear.
- ___ Check operation of (reverse) steering lock (if equipped).
- ___ Verify operation of manual/automatic lift-in-reverse control (if equipped).
- ___ Inspect tie-rod and the tie-rod ends for excessive damage/wear. Lubricate tie-rod ends. Check that tie-rod boot is in place and completely over the end of the tie-rod. Replace entire tie-rod end if boot is damaged.

Annual/100,000 Miles Inspection

- ___ Inspect pivot connections for worn bushings/wear washers. Replace if necessary. Torque all hardware to spec. (Pg 7/ENG Drawing).
- ___ Check hanger and air spring mounting plate connections to frame.
- ___ Check air system for leaks.
- ___ Test air tank pressure protection valve (PPV) if equipped.
- ___ Check brake chambers/brakes for damage and proper function.

CAUTION Failure to exhaust all pressure from the air system before vehicle work can cause serious injury.

CAUTION Failure to torque bolts/nuts of suspension components to specifications can result in suspension failure and void the warranty.

Adjust the suspension ride height by installing a 1" or 2" A/SPG Spacer.

Note: The hanger locator flange must be relocated to match the ride height determined by the air spring spacer.

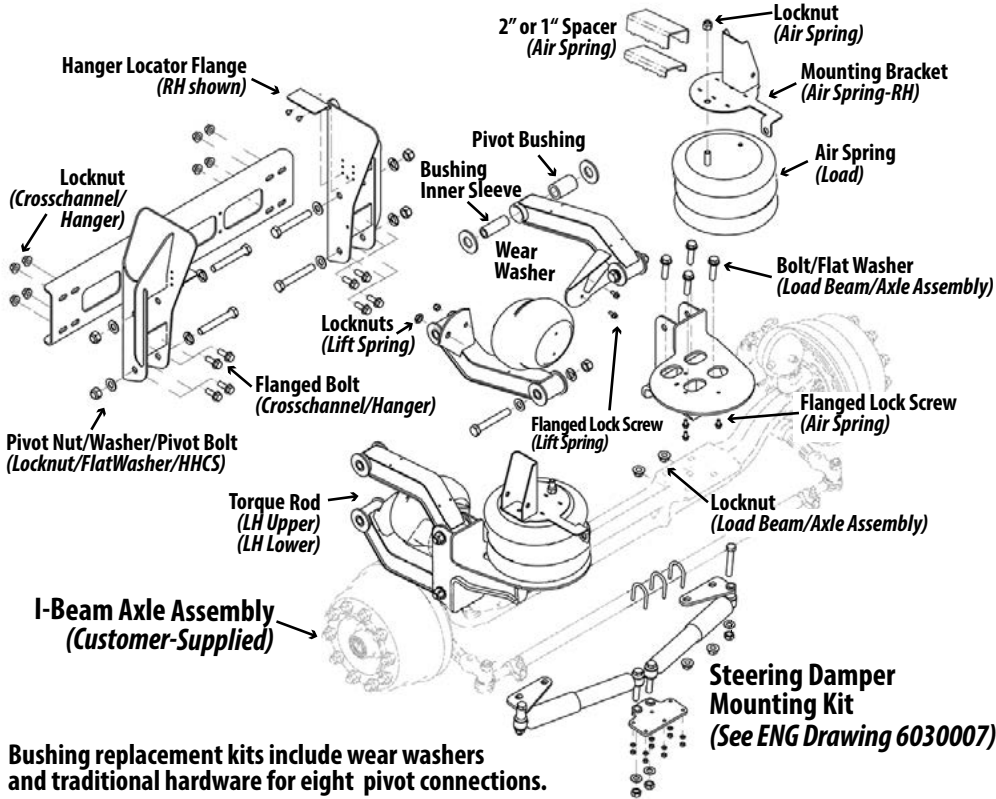

Figure 2.
Suspension Components—
Single A/SPG mounting stud
 Refer to the suspension model engineering drawing for the individual component part number.

Adjust the suspension ride height by installing a 1" or 2" Spacer.

(Note: The hanger locator flange must be relocated to match the ride height determined by the A/SPG spacer.)

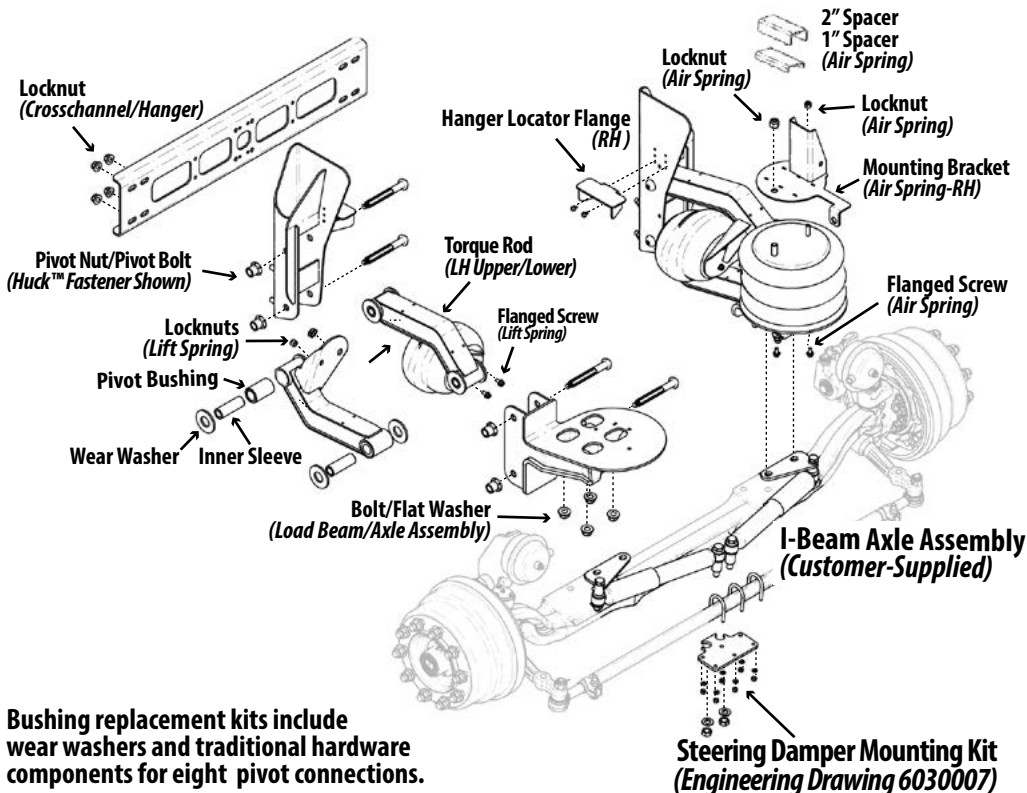

Figure 3.
Suspension Components—
Dual A/SPG mounting stud
 Refer to the suspension model engineering drawing for the individual component part number.

2361000 TRUCK SUSPENSION – BUSHING REPLACEMENT/TORQUE SPECIFICATIONS

Part Number (Component)	Item Description	Size	Torque Values	
			foot-pound	Newton-meter
6040161 - Bushing Kit	Pivot Bolt/Nut (HHCS/Locknut)	7/8"-14NF	500 ft-lb	678 N-m
6040160 - Bushing Kit	No Pivot Hardware	NA	500 ft-lb	678 N-m
Fasteners	Locknut - (Air Spring-Load)	3/4"-16NF	50 ft-lb	68 N-m
	Locknut - (Air Spring-Load)	1/2"-13NC	25 ft-lb	35 N-m
	Flanged Lock Screw - (Air Spring-Load)	3/8"-16NC	25 ft-lb	35 N-m
	Locknut - (Air Spring-Lift)	3/4"-16NF	50 ft-lb	68 N-m
	Locknut - (Air Spring-Lift)	1/2"-20NF	25 ft-lb	35 N-m
	Flanged Lock Screw - (Air Spring-Lift)	3/8"-16NC	25 ft-lb	35 N-m
	Locknut - (Crosschannel)	5/8"-11NC	160 ft-lb	217 N-m
	Locknut - (Load Beam/Axle Assembly)	3/4"-16NF	310 ft-lb	420 N-m
	HHCS/Locknut - (Tie Rod/Steering Damper)	3/4"-10NC	160 ft-lb	217 N-m
	Locknut - (U-Bolt Steering Damper Mount)	3/8"-16NC	30 ft-lb	41 N-m

Torque values reflect a lubricated thread condition (Nuts are pre-lubed). Do not overtorque.

CAUTION Suspension is shipped with minimal torque applied to fasteners. All fasteners must be re-torqued after first 6,000 miles of operation. Failure to install and maintain fasteners at torque specifications could result in suspension failure and void the warranty.

Vehicle Preparation

Park the vehicle on a level surface. Chock wheels to keep vehicle from moving.

Exhaust all the air from the air system.

Disassemble suspension, if necessary, to reach the pivot connections.

CAUTION Failure to properly chock wheels and exhaust the air system could allow vehicle movement that could result in serious injury.

Bushing Replacement Procedure

1. Remove the pivot hardware by cutting/grinding away the Huck® Collar. Discard pivot hardware.
2. Inspect wear washers for excessive wear/damage. Replace, if necessary.
3. Remove bushing assembly from the torque rod and discard. Clean the rod eye of any foreign debris or corrosion.
4. Apply Energy Suspensions® Formula 5 Prelube to the bore (inside) of new bushings.
NOTE: Do not substitute - special urethane bushing lubricant included with all bushing kits.
5. Install bushing in the eye of the torque rod.
NOTE: Mallet/press may be needed.
6. Press inner sleeve into the installed bushing. Center the sleeve inside the bushing so that both ends extend slightly past the sides of the bushing equally on both sides.

7. Assemble pivot connection with one wear washer on each side of the bushing (Fig 4). Inner sleeve must be flush with or extend slightly past the outside of the wear washers.
8. Torque pivot nut to specifications (500 ft-lb - 678 N-m).
9. Reassemble suspension, if necessary. Torque components to specifications (Chart).
10. Check and adjust wheel toe-in setting (between 1/32" and 3/32").

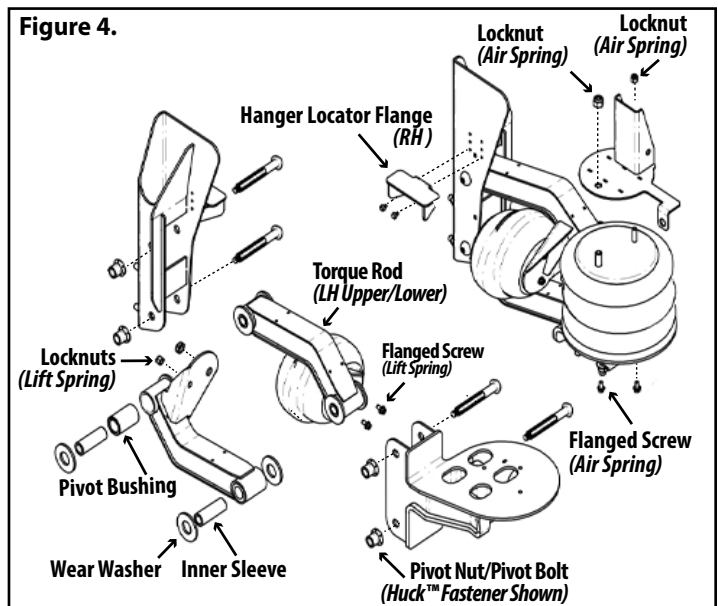

Terms and coverage in this warranty apply only to the United States and Canada.

Ridewell Suspensions warrants the suspension systems manufactured by it to be free of defects in material and workmanship. Warranty coverage applies only to suspensions that have been properly installed, maintained and operated within the rated capacity and recommended application of the suspension. The responsibility for warranty coverage is limited to the repair/replacement of suspension parts. The liability for coverage of purchased components is limited to the original warranty coverage extended by the manufacturer of the purchased part.

All work under warranty must have prior written approval from the Ridewell warranty department. Ridewell has the sole discretion and authority to approve or deny a claim and authorize the repair or replacement of suspension parts. All parts must be held until the warranty claim is closed.

Parts that need to be returned for warranty evaluation will be issued a Returned Materials Authorization (RMA). Parts must be returned to Ridewell with the transportation charges prepaid. The transportation charges will be reimbursed if the warranty claim is approved.

This non-transferable warranty is in lieu of all other expressed or implied warranties or representations, including any implied warranties of merchantability or fitness or any obligations on the part of Ridewell. Ridewell will not be liable for any business interruptions, loss of profits, personal injury, any costs of travel delays or for any other special, indirect, incidental or consequential losses, costs or damages.

Contact the Ridewell Warranty Dept. at 417.833.4565 - Ext. 135, for complete warranty information.