

# RUL-245 - Truck

## *NonSteerable - Auxiliary Axle Suspension*

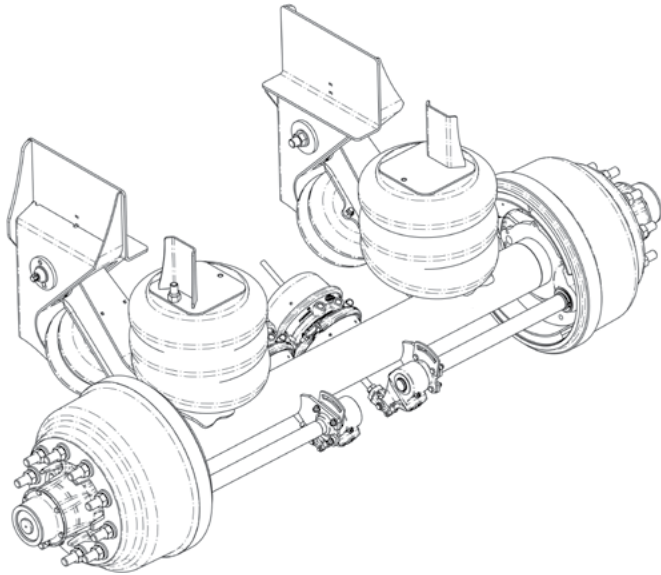

## Installation and Service Manual

<b>Suspension Identification</b> .....	<b>2</b>
<b>Installation</b>	
Prior to Installation .....	3
Axle Integration	
I-Beam Axle Integration .....	4
Suspension Mounting .....	6
Air Control Kit (ACK) Components - Lifiable Axle .....	7
<b>Maintenance</b>	
<b>Recommended Service Intervals</b> .....	<b>8</b>
<b>Torque Specifications</b> .....	<b>9</b>
245 Truck Components – Drum Brakes .....	10
245I Truck Components – Customer-Supplied I-Beam Axle .....	11
<b>Procedure – Narrow Bushing Replacement Tool</b> .....	<b>12</b>
<b>Bushing Replacement–Suspension Manufactured Before 2009</b> .....	<b>14</b>
<b>Axle Alignment</b> .....	<b>15</b>
<b>Warranty</b> .....	<b>16</b>



## SUSPENSION IDENTIFICATION

### Introduction

The Ridewell Universal Lift (RUL) 245 Truck Suspension is available for use in a range of applications. The suspension can be purchased with or without an integrated axle.

Refer to the engineering drawing for detailed information on the suspension system components and operating parameters.

### Suspension Identification Tag

A (606-) **Installation/Assembly Number** will be listed as the **Part Number** when other system components are factory installed with the suspension (Figure 1).

The **Suspension Number** and **Serial Number** on the Suspension ID Tag refer to the model and the date of manufacture of an individual suspension system.

Please refer to the suspension number/part number and serial number on the Suspension Identification Tag when contacting Ridewell for customer service, replacement parts and warranty information.

### Axle-Body Identification Tag

The **Base-Axle Part Number (165-)** and the **Serial Number** of the axle tube are listed on the Axle-Body ID Tag of Ridewell-branded round axles (Figure 2).

The **Base-Axle Part Number** refers to Ridewell-branded round axles manufactured in various axle wall thicknesses and widths.

More information on Ridewell-branded axles can be found in the "Trailer Axle Parts Guide" (9710029).

### Notes and Cautions

All work should be completed by a properly trained technician using the proper/special tools and safe work procedures.

Read through the entire Installation and Service Manual (ISM) before performing any procedures.

The ISM uses two service notes to provide important safety guidelines for the suspension operation.

The service notes are defined as:

"NOTE": Provides additional instructions or procedures to complete tasks and make sure that the suspension functions properly.

**CAUTION** Indicates a hazardous situation or unsafe practice that, if not avoided, could result in equipment damage and serious injury.

 <b>RIDEWELL SUSPENSIONS</b> The Engineered Suspension Company	
PART NO:	
SUSP. NO:	
SERIAL NO:	
GROSS AXLE WEIGHT RATING CERTIFICATION IS PER THE FINAL STAGE MANUFACTURER OR ALTERER. THIS PRODUCT MAY BE COVERED UNDER ONE OR MORE PATENTS, ADDITIONAL PATENTS MAY BE PENDING. www.ridewellcorp.com (800) 641-4122	

**Figure 1.**  
The Suspension Model (Suspension Number) and date of manufacture (Serial Number) are listed on the Suspension Identification Tag.

 <b>RIDEWELL SUSPENSIONS</b>			
MODEL:		PART NO.	
SERIAL NO.		CAPACITY	TON

**Figure 2.**  
The Base-Axle Part Number (165-) and the Serial Number assigned to the axle tube are listed on the Axle-Body Serial Identification Tag.

## Prior to Installation

Refer to the engineering drawing to confirm dimensional requirements and the range of ride heights available. Operating the suspension outside of design parameters can result in improper performance, damaged equipment, and void the warranty.

The methods and procedures listed in this manual are considered to be general practices. Installations can vary and procedures should be adapted for different vehicles, as needed.

- The Gross Axle Weight Rating (GAWR) is determined by the system component with the lowest load rating. Please consult with tire, wheel, axle and brake manufacturers before installation to determine the GAWR.
- If vehicle chassis modifications are required, consult with the vehicle manufacturer to ensure that such changes are permitted.
- Welding or altering suspension components is not permitted without the express written permission of Ridewell Suspensions.

## Installer Responsibilities

The installer of the suspension has the sole responsibility for proper attachment of the suspension system to the vehicle chassis.

- The installer is responsible for locating the suspension system on the vehicle to provide the proper load distribution.
- The installer must verify that vehicle crossmembers are positioned to support the suspension at the installing location.
- It is the installer's responsibility to determine that axle spacing conforms to any applicable federal and local bridge laws.
- The installer must verify that air reservoir volume requirements are met after suspension installation. Consult the vehicle manufacturer or Federal Motor Vehicle Safety Standards (FMVSS) 121 for more information.
- The installer must verify there is sufficient clearance for proper functioning of the auxiliary suspension and installed components - air springs; brake chambers; axle; and, tires and wheels.

## Axle Integration

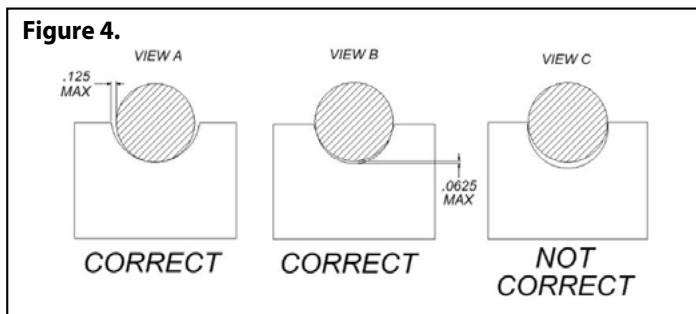
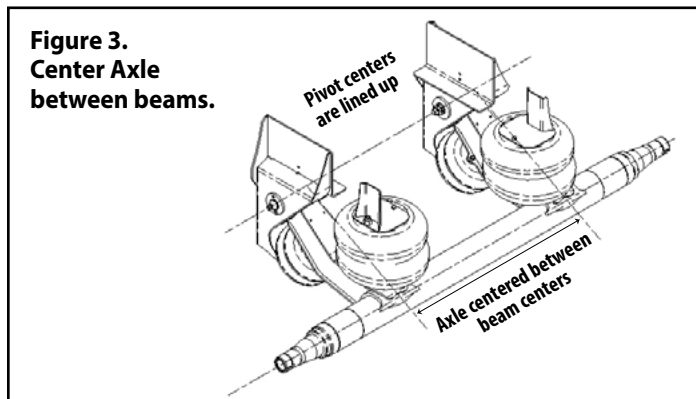

Suspension systems are available with and without a factory integrated axle. Customer-supplied axle assemblies must be positioned and oriented (rotated) properly before welding the axle.

Use the top-center mark on the axle, if available, to identify the center of the axle and orient the axle assembly on the suspension. The axle assembly should be installed so that the camshafts, when activated, rotate in the same direction as the wheels.

**CAUTION** Failure to follow procedures and design specifications could result in injury, damage to the axle or suspension and void the warranty.

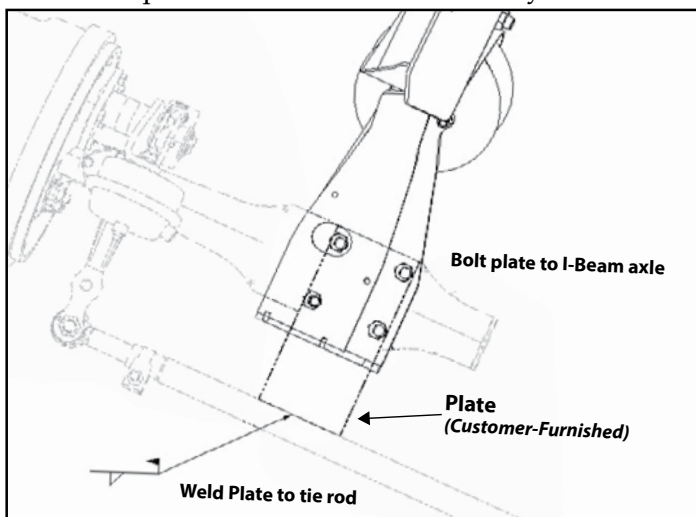

Steel plate is welded to tie-rod to lock the I-Beam Axle knuckle and make the non-steering axle.

### Weld Preparation

Position the joint to be welded in a flat or horizontal position. All grease, dirt, paint, slag or other contaminants must be removed from the weld joint.

The axle and suspension components should be at a minimum temperature of 60°F (15.5°C). Pre-heat the weld zone to the axle manufacturer's recommended pre-heat temperature, if required.

### Welding Procedure

1. Center the axle assembly on the beams (Fig. 3).
2. Check the engineering drawing for the brake component orientation (rotation) before clamping into place and making the final welds.
  - 2.1 Drum brake camshafts are spaced off the tail of the trailing arm beam. Make sure the brake chamber brackets are oriented properly and clamp the axle assembly into place.
  - 2.2 Disc brake assemblies have a right- and left-hand caliper assembly. Make sure the calipers are located on the correct side and rotated to the proper position before clamping the axle assembly into place.
3. Check the gap between the axle and the axle seats before welding (Fig. 4). Side gaps should be no greater than 1/8". The gap at the bottom of the axle seat should be no greater than 1/16".
4. Weld the axle to the seat according to Ridewell Weld Process #1 (Pg 5).

NOTE: Mounted air springs should be covered to protect them from welding spatter.

### I-Beam Axle Integration

1. Make sure that suspension beams are located at the proper frame width with the locator tabs on the bottom of the beams. Center the axle between the beams and clamp into place.
2. Drill four 25/32" holes in each beam. Drill two holes in front of the axle and two behind the axle.
3. Fasten each beam to the axle with four 3/4" Grade-8 fasteners. Check to make sure axle and beams are square before final tightening of nuts.
4. Adjust the wheel toe-in to the recommended setting between 1/32" to 3/32".
5. Lock knuckles in place to prevent self-steering (Fig 5).

NOTE: A bolt-on tie-rod/steering damper lock kit (P/N 6030007) is available.

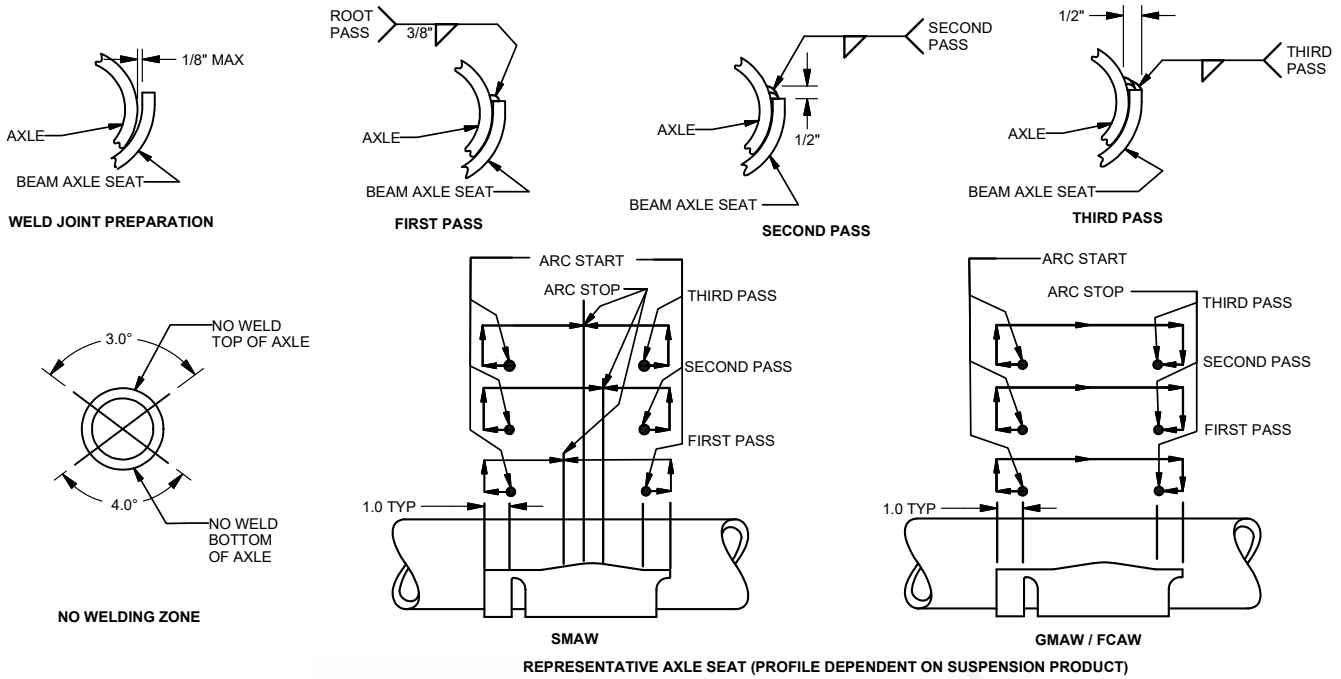

- CAUTION:** All welds must be kept away from the top and bottom of the axle where maximum stresses occur (see "NO WELDING ZONE" illustration above). Do not test-weld the arc on any part of the axle tube.
- All welders and welding operators should be certified as per the requirements of the American Welding Society (AWS) or equivalent. All electrodes used should meet the AWS specifications and classifications for welding carbon and low-alloy steels.
- Recommended Welding Methods:** Shielded Metal Arc Welding (SMAW), Gas Metal Arc Welding (GMAW) or Flux Cored Arc Welding (FCAW). The welding method used and the electrode selected must develop a minimum weld tensile strength of 70,000 psi per AWS specifications. The best fusion and mechanical properties will be obtained by using the voltage, current, and shielding medium recommended by the electrode manufacturer. If the SMAW method is used, the stick electrodes must be new, dry, free of contaminants and stored per AWS specifications.
- Weld Joint Preparation:** The joint to be welded should be positioned in the flat or horizontal position. All grease, dirt, paint, slag or other contaminants must be removed from the weld joint without gouging the axle tube. **CAUTION:** Never weld when the axle is cold. The axle and beam assemblies to be welded should be at a temperature of at least 60°F (15°C). Pre-heat the weld zone to the axle manufacturer's recommended pre-heat temperature, if required. This will reduce the chance of an area of brittle material forming adjacent to the weld.
- The axle should fit into the beam assembly with a maximum root gap of 1/8-inch between the axle and the beam axle seat (see "WELD JOINT PREPARATION" illustration above).
- NOTE:** Clamp the axle to the beam axle seat with a C-clamp prior to welding to make sure that proper contact occurs (see "CORRECT" illustration below).
- Ground the axle to one of the attached axle parts such as the brake chamber brackets, cam brackets or brake spider. Never ground the axle to a wheel or a hub as the spindle bearing may sustain damage.
- Multiple pass welding should be used on the beam/axle connection using the following guidelines: 8.1-Total fillet weld size should be 1/2-inch. 8.2-Weld pass starts and stops should be performed as illustrated above. 8.3-Never start or stop welds at the end of the weld joint. 8.4-Each pass must be accomplished in one or two segments. 8.5-Start welds at least 1-inch from the end and backweld over the start. Backstep fill all craters. 8.6-If process is not GMAW all slag must be removed between passes. 8.7-Welds must go to within 1/8-inch +/- 1/16-inch of the ends of the axle seat and must not go beyond or around the ends of the axle seat. 8.8-Post-weld peening is recommended, but not required: Needle peen the entire toe of the second pass, including around the ends of the axle seat. Hold the needles perpendicular to the axle. A uniform dimpled pattern will appear when properly peened.

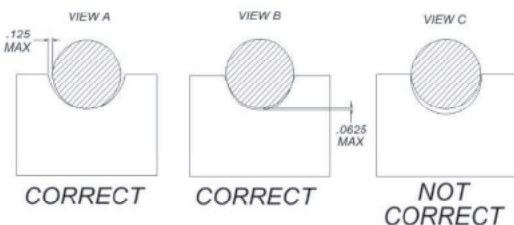

F	16101	ADDED MAXIMUM TO 5, ADDED GMAW NOTE TO 8.6 UPDATED CORRECT VIEWS	2/10/2016	G.H.	B.B.	CJB
E	15101	REVISED TEXT. REMOVED LIST OF MODELS.	6/30/15	G.H.	MDJ	CJB
REV	PROJECT	DESCRIPTION	DATE	BY	CHK	APPD
DRAWN BY: CBC		2/1/2016		<b>RIDEWELL CORPORATION</b> PO BOX 4586 SPRINGFIELD, MISSOURI 65808		
CHECKED: MDJ		2/21/2003				
APPROVED: CJB		2/21/2003				
PROJECT NO: 03103		SCALE: A-SIZE: NTS		TITLE: RIDEWELL WELD PROCESS #1, 5" DIA. AXLE, 3 PASS WELD		
MATERIAL:		WEIGHT:		SHEET 1 OF 1		
				PART NO: WELD PROCESS #1		REV: F



## Suspension Mounting

Refer to the engineering drawing for the suspension travel table; mandatory customer-supplied cross-member locations; the recommended bolt-hole locations for suspension mounting; and, the suspension spacing and clearance requirements.

### Bolt-On Installation Procedure

Grade-8 bolts, flanged locknuts or locknuts with hardened washers for suspension mounting are supplied by the installer.

The hanger crosschannel should be installed after axle integration. Torque locknuts to 45-50 ft-lb.

Suspension heights can be adjusted with a 1" or 2" air spring/hanger mounting spacer kit (Page 10).

1. Locate the hangers and air spring mounting plates/spacers on the chassis and clamp firmly into place.  
**CAUTION** Corresponding hanger mounting spacer must be installed with the air spring spacer. All Hangers/Mounting Plates/Spacers must have full contact with the bottom of the vehicle frame.
2. Check that hangers/mounting plates/spacers are evenly located and square to the frame. Verify that location provides adequate clearance for the assembled suspension components.
3. Center-punch and drill eight bolt-holes (min 5/8") in each frame hanger. Center-punch and drill two bolt-holes (minimum 5/8") in each air spring mounting plate.  
NOTE: Space the bolt-holes for mounting as far apart as possible if the recommended bolt-hole locations are not available.  
**CAUTION** Check to make sure that wires, hoses or other components located within the chassis are not affected by drilling the bolt-holes.
4. Bolt suspension assembly to vehicle chassis with 5/8" Grade 8 bolts and locknuts.
5. Attach the load springs to the air spring mounting plates. Torque to specifications (Page 9).
6. Install/connect the air control kit (ACK). Check the air system after installation for leaks (Page 7).
7. Perform final assembly and inspection and align the suspension per TMC or SAE recommended standards. Alignment should be performed with suspension at installed ride height (Page 15).

### Regulate load with air spring pressure

The load capacity of the auxiliary axle is adjusted by increasing or decreasing the pressure to the air springs. By applying more air, the lift axle takes on a greater percentage of the load's weight. The load capacity is decreased as the air pressure decreases.

Accurate readings of the load capacity can be obtained by parking a loaded vehicle over a calibrated scale and lowering the axle onto the scale. The air pressure to the air springs is manually adjusted up or down to obtain the axle load weight at various air pressures.

**CAUTION** Do not exceed the rated load capacity of the suspension system or other components. Exceeding the capacity can cause component failure and void the warranty.

### Final Assembly and Inspection

1. Verify that all suspension components are torqued to specifications (Page 9).
2. Install wheels and tires.  
**CAUTION** When lowering an auxiliary axle on an unloaded vehicle, pressure to the load air springs must be reduced to below 10 psi. Failure to reduce the air pressure could cause the vehicle's drive axles to rise from the ground and the vehicle could roll in an unsafe manner.
3. Check that tires are inflated to recommended pressure. Check wheel hubs for proper level of lubricant recommended by the manufacturer.
4. Lift the axle to the raised position. Check the air system tubing and connections for leaks.
5. Check that wheels can rotate freely and that brakes are properly adjusted.
6. Raise and lower the suspension assembly through the entire range of travel. Check for sufficient vehicle clearances of air springs, brake chambers and other components.  
**CAUTION** Do not lower the auxiliary axle while the vehicle is moving above 10 mph.

## Air Control Kit (ACK) Components - Lifiable Axle

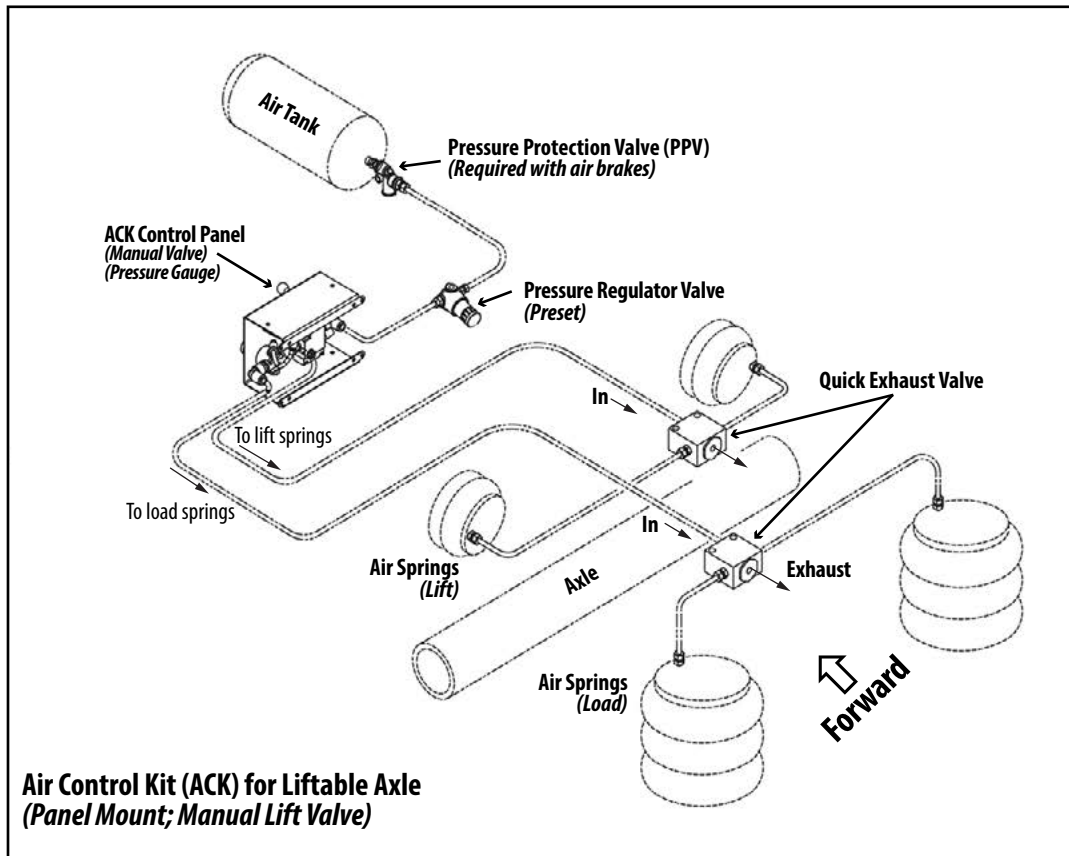

The air control kit consists of a pressure regulator with a gauge; connected to an air valve that is operator-controlled by a manual knob or by an electric switch.

The operator uses the air control kit to control the pressure to the air springs to support different loads.

Contact Ridewell Customer Service for the various manual/electric ACK configurations available. Installation will vary by ACK configuration.

**CAUTION** The installer is responsible for ensuring air system requirements comply with the appropriate Federal Motor Vehicle Safety Standards.

### Air Control Kit – Troubleshooting

Problem	Possible Cause	Solution
<b>Air springs fill but do not exhaust.</b>	<ul style="list-style-type: none"> <li>– Obstructed air line.</li> <li>– Faulty controls wiring.</li> <li>–</li> <li>– Manual override pushed in.</li> </ul>	<ul style="list-style-type: none"> <li>– Check for pinched/blocked lines.</li> <li>– Check controls wiring with voltmeter. Correct wiring/installation.</li> <li>– Release manual override.</li> </ul>
<b>Air system leaks down after a short period of time.</b>	<ul style="list-style-type: none"> <li>– Leak in air system beyond accepted standards. NOTE: Some valves will leak at an acceptable rate.</li> </ul>	<ul style="list-style-type: none"> <li>– Pressurize system. Spray soapy water solution onto the tubing, valves and fittings. Check for bubbles (leaks).</li> <li>– Check that tubing cuts are straight and smooth. Re-cut and reassemble fitting joints, if necessary.</li> </ul>
<b>Auxiliary unit will not stay up</b>	<ul style="list-style-type: none"> <li>– Loose air fitting connection/Damaged air lines.</li> <li>– Air lines to lift and load air springs are reversed.</li> <li>– Damaged or worn air springs.</li> </ul>	<ul style="list-style-type: none"> <li>– Check and retighten fittings. Repair or replace component, as necessary.</li> <li>– Check installation. Air line from regulator goes to (load) air springs.</li> <li>– Replace air spring if worn or damaged.</li> </ul>
<b>Auxiliary unit not achieving correct lift</b>	<ul style="list-style-type: none"> <li>– Air lines to lift and load air springs are reversed.</li> <li>– Lift air springs do not have proper air pressure.</li> <li>– Interference with driveline/other chassis components.</li> <li>– Air control system not installed correctly.</li> </ul>	<ul style="list-style-type: none"> <li>– Check installation. Air line from regulator goes to (load) air springs.</li> <li>– Check for loose fittings or worn/damaged lines. Verify air tank pressure with gauge.</li> <li>– Visually inspect auxiliary unit operation for proper clearance. Retighten any loose fasteners.</li> <li>– Check air control kit installation; refer to OEM installation procedures.</li> </ul>

## Recommended Service Intervals

Ridewell Suspensions recommends these minimum service intervals for standard duty, on-highway usage applications. More frequent intervals are recommended for heavier duty applications.

### Daily/Pre-Trip Inspections

- \_\_\_ Check tires for proper inflation, damage or excessive wear.
- \_\_\_ Check wheel-ends for obvious signs of lubricant leakage. Check for missing components.
- \_\_\_ Check axle assemblies for damage/loose components.
- \_\_\_ Visually inspect suspension structure for signs of damage or excessive wear.
- \_\_\_ Check for loose or missing bolts/nuts. Check for irregular movement in suspension components.
- \_\_\_ Make sure air controls are operating properly. Drain all moisture from air reservoirs.

### First 6,000 miles of use

- \_\_\_ Torque suspension components to specifications (Page 9/Engineering Drawing).  
NOTE: Do not re-torque shear-type pivot bolt.
- \_\_\_ Verify the suspension is operating at the designed ride height.

#### Refer to these Technology & Maintenance Council (TMC) publications for maintenance information

- RP 609 Brake Adjuster Installation/Maintenance
- RP 618 Wheel Bearing Adjustment Procedure
- RP 619 Air System Inspection Procedure
- RP 622 Wheel Seal and Bearing Removal, Installation, and Maintenance
- RP 631 Wheel End Lubrication Recommendations
- RP 643 Air Ride Suspension Maintenance
- RP 728 Trailer Axle Maintenance

### Every 12,000 miles of use

- Inspect air springs for damage/excessive wear. Torque bolts/nuts to spec (Pg 9/ENG Drawing).
- Check air lines and connections for leaks.
- Lubricate Brake Cams and Slack Adjusters.

### First 50,000 miles of use

- \_\_\_ Torque suspension components to specifications (Page 9/Engineering Drawing).  
NOTE: Do not re-torque shear-type pivot bolt.
- \_\_\_ Check wheel ends for excessive play.

### Annually/100,000 miles of use

- \_\_\_ Inspect pivot connections for worn pivot bushings and replace, if necessary. Torque pivot hardware and component bolts/nuts to specifications (Page 9/ENG Drawing).
- \_\_\_ Check suspension hanger and air spring mounting plate connections to frame.

#### Check lubrication level in wheel ends:

- \_\_\_ 1) Oil-Filled Wheel Ends:  
Refill/Replace lubricant as needed  
(TMC RP 631-“100K/Annual Inspection”).
- \_\_\_ 2) Semi-Fluid Grease:  
Pull outer bearing and visually inspect the lubrication level. Refill/Replace as needed  
(TMC RP 631-“Level 3 Lubrication Level Inspection”) (TMC RP 618-“Wheel Bearing Adjustment”).
- \_\_\_ Check air system for leaks.
- \_\_\_ Test air system pressure protection valve (if equipped).
- \_\_\_ Check brake chambers and brakes for damage and proper function.

**CAUTION** Failure to torque bolts/nuts of suspension components to specifications can result in failure of the suspension and void the warranty.

## Pivot Bushing Inspection Procedure

Park the unloaded trailer on a level surface. Set the brakes and chock the tires so vehicle cannot move during inspection.

Insert the flat end of a pry-bar between one side of the hanger sidewall and the wear washers. Move the pry-bar back-and-forth and look for excessive movement of the beam (NOTE: A small amount of beam

movement because of the rubber flexing is normal). Inspect the wear washers for excessive wear/damage. Repeat the pry-bar process and wear washer inspection on the other side of the hanger. If any large/easy movement or damaged wear washers is observed, drop the beams for further inspection. Replace components as necessary.



## RUL 245 TRUCK SUSPENSION — BUSHING REPLACEMENT/TORQUE SPECIFICATIONS

Part Number (Component)	Item Description	Size	Torque Values	
			foot-pound	Newton-meter
6040128-Bush Kit 6100044-BushTool	Pivot Bolt/Nut - (Shear-Type Bolt/Locknut) <i>Requires E-20 Torx® socket (RW #6100054)</i>	7/8"-9NC	<i>Do not lubricate bolt/nut threads. Use 1"-drive impact wrench to tighten until Torx® head shears off.</i>	
6040078-Bush Kit 6100044-Bush Tool	Pivot Bolt - Hex Head Cap Screw (HHCS) Pivot Nut - (Locknut)	7/8"-9NC	500 ft-lb	678 N-m
<b>Suspensions Manufactured Before 2009</b>				
6040193-Bush Kit Wide (6 3/4") <i>Glue-In Bushing Instructions-Pg 14</i>	Pivot Bolt - Ecc. Bolt/Top Lock Locknut 2450000-to-2450021      2457666D005 24510700                    2457666D007 2457666D003                2457666D008	1 1/4"-7NC	1000 ft-lb	1356 N-m
6040192-Bush Kit Wide (6 3/4") <i>Glue-In Bushing Instructions-Pg 14</i>	Pivot Bolt - HHCS/Locknut 2457615D000                2457666D01 2457616D000                2457666D101 2457666D000                2457666D0011 2457666D002	1 1/4"-6NC	1000 ft-lb	1356 N-m
<b>Clamped Bushing</b> <i>See ENG Drawing</i>	2457572xxxx 2457661xxxx 2457718xxxx			
<b>Fasteners</b>	Locknut (Air Spring)	1/2"-13NC	25 ft-lb	35 N-m
	Locknut (Air Spring)	3/8"-16NC	25 ft-lb	35 N-m
	Combo Port (Air Spring)	3/4"-16NF	45-50 ft-lb	61-68 N-m
	Bolt (Air Spring)	3/8"-16NC	25 ft-lb	35 N-m

Torque values reflect a lubricated thread condition (Nuts are pre-lubed). Do not overtorque.

**⚠ CAUTION** Suspension is shipped with minimal torque applied to fasteners. All fasteners must be re-torqued after first 6,000 miles of operation. Failure to install and maintain fasteners at torque specifications could result in suspension failure and void the warranty.

### P/N 6100044 Narrow Bushing Replacement Tool

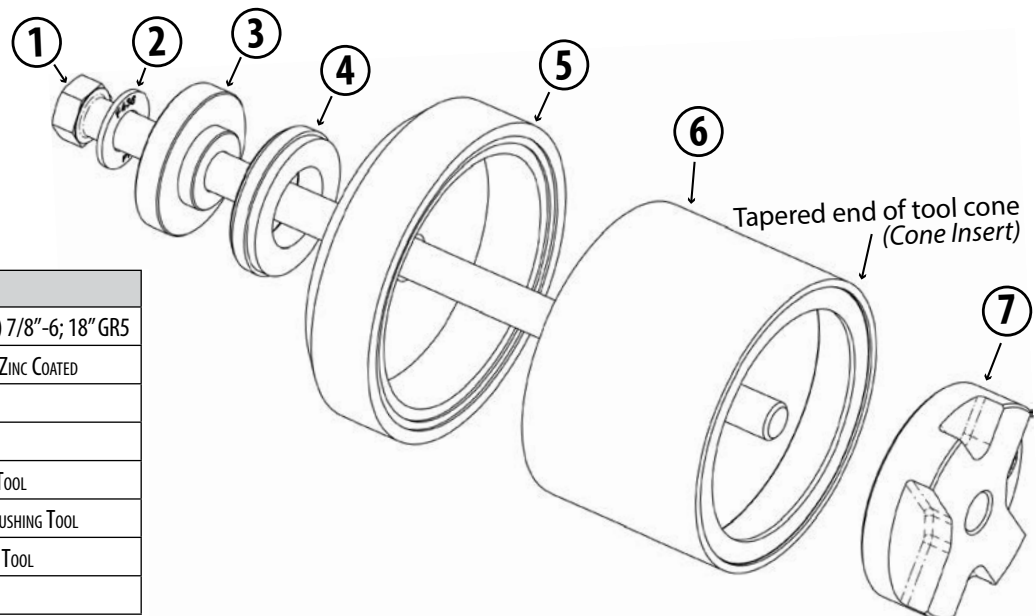

No.	Part No.	Item Description
1	1130088	HEX HEAD CAP SCREW (HHCS) 7/8"-6; 18" GR5
2	1160036	FLAT WASHER — 7/8" F436 ZINC COATED
3	1120051	BEARING COLLAR
4	1660009	THRUST BEARING
5	6100089	ENDCAP — NARROW BUSHING TOOL
6	6100092	CONE ASSEMBLY — NARROW BUSHING TOOL
7	6100091	PLUNGER — NARROW BUSHING TOOL
—	1980014	EXTREME PRESSURE LUBRICANT

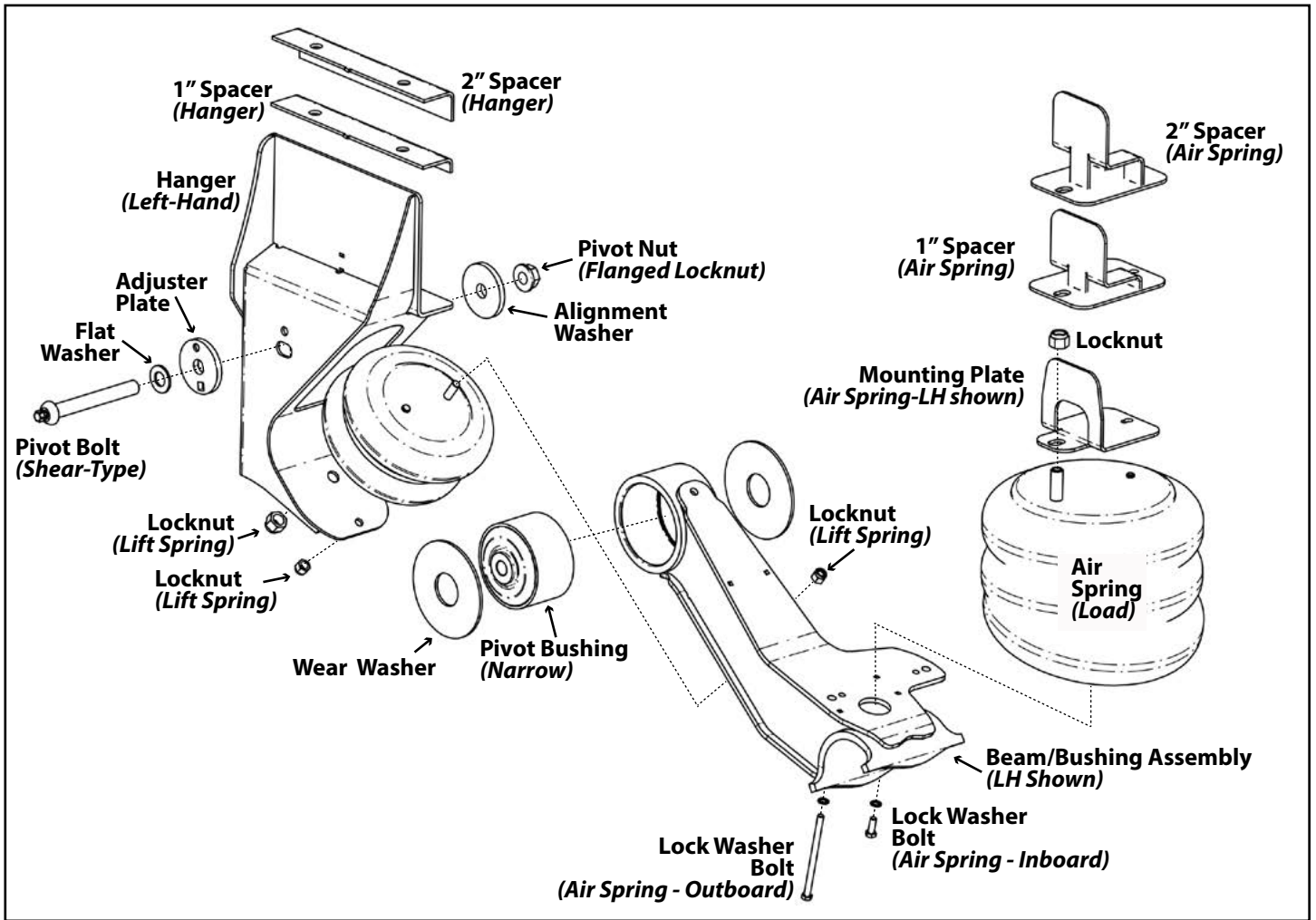

**Figure 6.**  
**245 Truck Suspension Components – Drum Brakes**  
 Refer to the suspension model engineering drawing for the individual component part number.

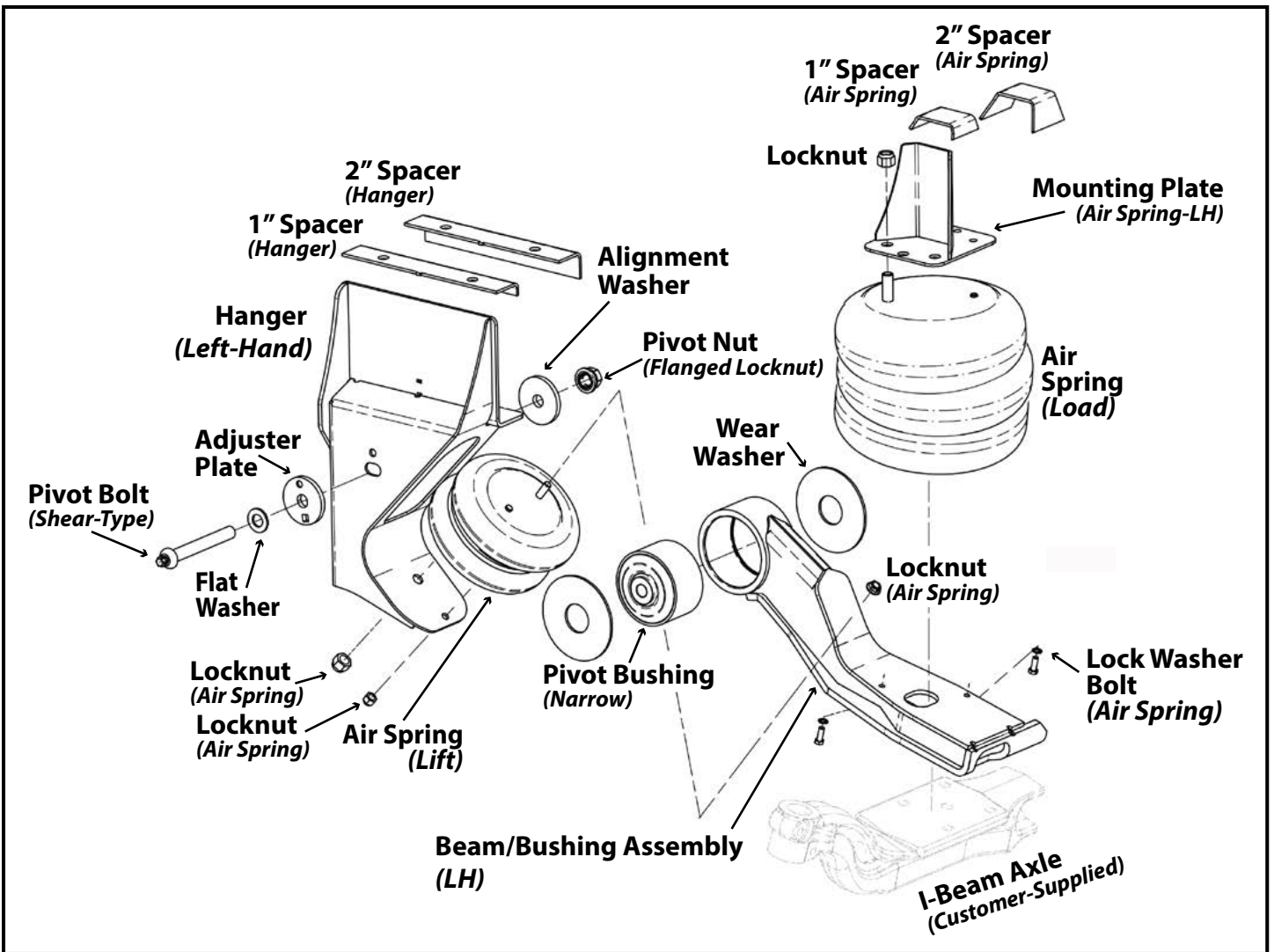

**Figure 7.**  
**245I Truck Suspension Components – Customer-Supplied I-Beam Axle**  
 Refer to the suspension model engineering drawing for the individual component part number.

## Replacement Procedure – Narrow Bushing Replacement Tool #6100044

### Vehicle Preparation

Park vehicle on a level surface. Chock wheels. Raise vehicle to a height that removes the load on the suspension. Support with jack stands.

Disconnect the linkage from the height control valve(s), if equipped. Exhaust all air from the system.

**CAUTION** Failure to properly chock wheels, exhaust the air system and safely support the vehicle could allow vehicle/suspension movement that could result in serious injury.

### Disassemble the suspension

Remove wheels and tires, if necessary. Remove shock absorbers. Take the pivot connections apart. Remove and discard pivot bolt, flat washer and pivot nut. Inspect adjuster plate and alignment washer for wear/damage. Replace if necessary.

**CAUTION** Do not reuse pivot hardware.

Rotate beams down and away from frame. Inspect pivot-bolt holes and wear washers for unusual wear/damage. Repair or replace components as needed.

### Tool Assembly

Make sure thrust bearing is installed in the flat, outside edge of endcap. Inspect tool cone tapered insert and endcap for damage. Repair or replace bushing tool components as needed.

Lubricate the Hex-Head Cap Screw (HHCS) and the threads of the thrust bearing with Extreme Pressure Lubricant (P/N 1980014).

Thread the flat washer, the bearing collar and the endcap onto the HHCS until the bearing collar and endcap rest against the head of the HHCS. Place tool cone onto endcap (Figure 8).

NOTE: Failure to apply lubricant to the threads could result in decreased tool performance and reduce the life of the bushing tool.

### Bushing Removal

1. Push the hex-head cap screw through the bushing inner sleeve until the tool cone is against the beam eye. Thread the plunger onto the HHCS until the tool cone is held firmly against the beam (Figure 9).

NOTE: The smaller, tapered end of the cone is placed against the beam eye for both removal and installation of the bushing.

2. Verify tool cone is centered on the beam eye. Use a 1 5/16" socket on a 3/4"-drive impact wrench (1"-drive impact wrench recommended) to rotate Hex Head Cap Screw to pull bushing into cone.

NOTE: In some cases, a small amount of heat may be needed to break the bond between the bushing and beam eye.

Do not overheat. Allow the beam to cool before installing replacement bushing.

3. Remove bushing tool from the beam. Detach tool cone from endcap, remove bushing and discard

*continued on next page*

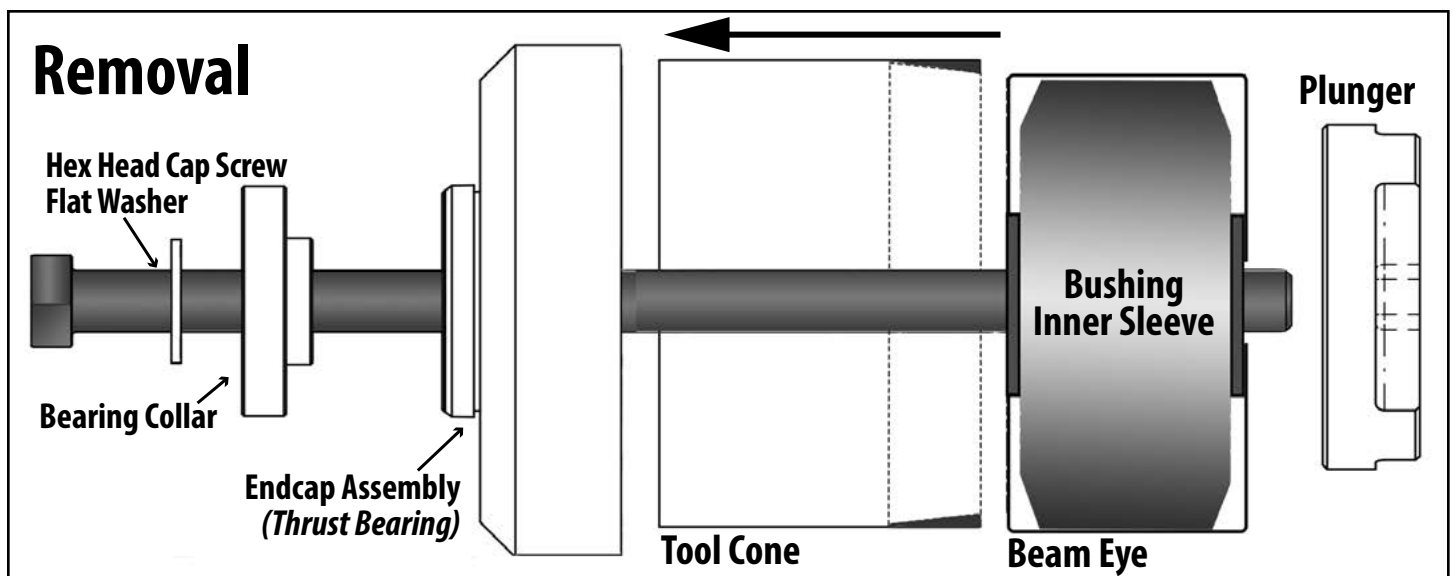

Figure 8.

Always place the tapered end of the cone against the beam eye for bushing installation and removal. The tapered cone expands the bushing during removal and compresses the bushing for installation.

## Replacement with Bushing Tool #610044 (continued)

### Tool Assembly

Thread the flat washer, the bearing collar and the endcap onto the hex-head cap screw until the bearing collar and endcap rest against the head of the HHCS.

### Bushing Installation

1. Use wire brush to clean debris /corrosion from eye.
2. Liberally apply P80<sup>®</sup> lubricant or a soap solution to the inside of the beam eye, the outside of the new bushing and inside the tool cone. Insert new bushing into the larger opening of the tool cone (Figure 9).
3. Center the smaller opening of the tool cone against beam eye. Push the hex-head cap screw through the bushing inner sleeve from the opposite side of the beam until the endcap rests against the beam eye.
4. Thread the plunger onto the hex-head cap screw until tool cone is held firmly against the beam. NOTE: The smaller opening of the tool cone is placed against the beam eye for both removal and installation of the bushing.
5. Verify bushing tool cone is centered on the beam eye. Use a 1 5/16" socket and 3/4-drive impact wrench (1"-drive impact wrench recommended) to rotate hex-head cap screw to press bushing into the beam eye.

6. Remove bushing tool from the beam. Check that bushing is centered inside the beam. Realign bushing if necessary.

### Reassemble suspension

Rotate beams into the hangers. Assemble the pivot connection – alignment washer, adjuster plate, wear washers, shear-type pivot bolt, flat washer and flanged locknut.

NOTE: Do not lubricate pivot bolt/nut.

Tighten locknut until adjuster plate pin is engaged and pivot connection hardware is snug against the hanger. Do not apply final torque until the axle alignment has been checked.

Connect the height control valve linkage (if linkage has been disconnected). Inflate air springs.

Install wheels and tires (if removed). Raise vehicle and remove support stands. Lower vehicle to ground.

Verify suspension ride height. Check axle alignment. Realign if necessary (Pg 15).

Tighten pivot bolt with a 1" drive impact wrench and E-20 Torx<sup>®</sup> socket (Ridewell tool #6100054) until Torx<sup>®</sup> head is sheared off.

Install shock absorbers.

**CAUTION** Failure to torque hardware to specifications can result in suspension failure and void the warranty.

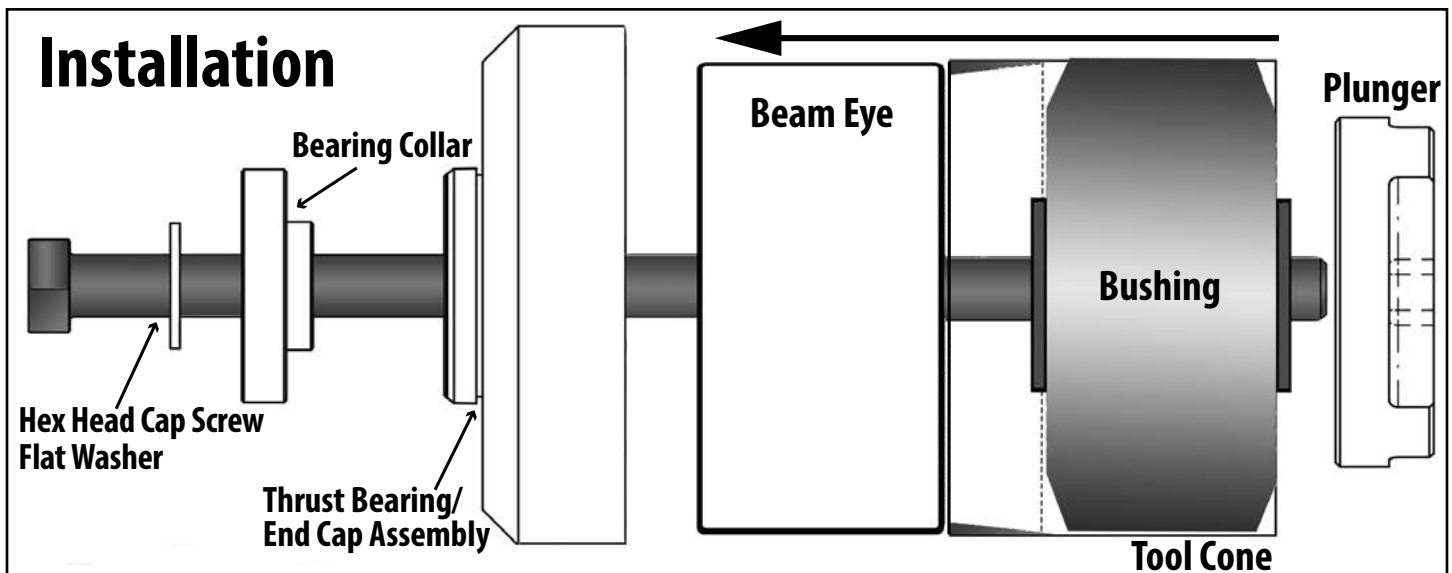

Figure 9.

Always place the tapered end of the cone against the beam eye for bushing installation and removal. The tapered cone expands the bushing during removal and compresses the bushing for installation.



## Bushing Replacement–245 Truck Suspension Manufactured Before 2009

### Vehicle Preparation

Park the vehicle on a level surface. Chock wheels to keep vehicle from moving. Raise vehicle to a height that removes the load from the suspension. Support with jack stands.

Disconnect the linkage from the height control valve(s), if equipped. Exhaust all air from the system.

Disassemble suspension to reach pivot connection.

**CAUTION** Failure to properly chock wheels, exhaust the air system and safely support the vehicle could allow vehicle movement that could result in serious injury.

### Bushing Replacement Procedure - Service Parts:

P/N 1987625B000 Epoxy - Fusor320 50ML (tube)

P/N 1117625C060 Bushing - Monopivot 62Duro

1. Remove bushing from load beam/sleeve (Fig 10).  
NOTE: Apply heat to outside of the sleeve with oxyacetylene torch to destroy any remaining bonding element to make removal easier.
2. Use a wire brush to remove remaining bonding residue, rubber, dirt, rust, etc, from sleeve bore.
3. Wash bore of the bushing sleeve with paint thinner. Wash surface of the replacement bushing with paint thinner.
4. Remove cap from Epoxy Adhesive 50ml tube kit. Squeeze out entire contents. Thoroughly mix the two-parts of the adhesive  
NOTE: Adhesive must be used within 20 minutes after mixing.
5. Spread mixed adhesive on entire surface of bushing. Apply adhesive to the inside of sleeve bore.
6. Press replacement bushing into the bore of the sleeve until bushing is centered.
7. Wipe excess adhesive from the ends of installed bushing with paint thinner.
8. Adhesive can be handled after four hours and will totally cure after 24 hours.

**CAUTION** Adhesive must be totally cured before returning vehicle to service.

Reassemble the suspension. Torque to specifications (Engineering Drawing).

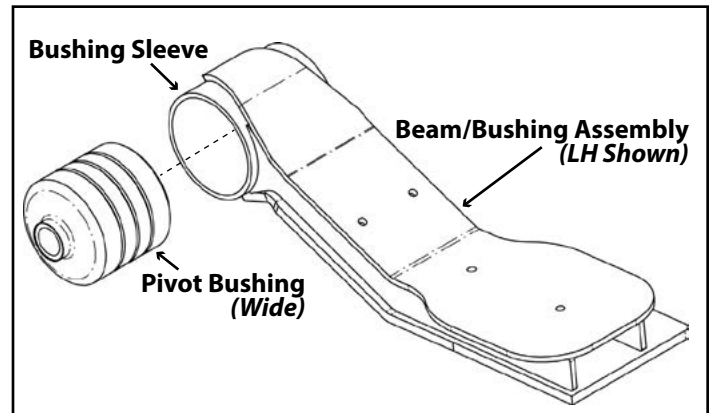

**Figure 10.**  
**Factory Bonded Wide Bushing (6 3/4").**  
**Refer to suspension model engineering drawing for component part numbers and torque values.**

Alignment should be performed on a level surface with the suspension at the desired ride height. Align the suspension per TMC- or SAE-recommended standards.

On a multiple-axle vehicle, the forward axle is moved into proper alignment, then the remaining axles are positioned so that they are parallel to the forward axle. A maximum tolerance of 1/8-inch difference from side-to-side of the forward axle and 1/16-inch difference from side-to-side for the aft axles is acceptable (Figure 13).

The RUL 245 suspension is equipped with the Ridewell Speed Set® alignment feature for manual alignment.

### Axle alignment procedure

1. Loosen the pivot nut enough for the beam to move within the hanger (Figure 11).  
**CAUTION** Do not reuse pivot hardware if Torx® head is damaged or missing. A new shear-type pivot bolt, flat washer and locknut must be installed and the Torx head sheared off to complete the alignment.
2. Locate the adjuster plate at the pivot connection. Insert a 1/2"-shank breaker bar into the square hole of the adjuster plate. Push on the breaker bar to move the beam forward or backward until the axle reaches alignment measurements (Figure 11).  
 NOTE: Verify that the pivot bushing is not wedged sideways during beam movement. The adjuster plate and alignment washer should move in unison with beam movement.
3. Tighten the pivot nut so that the beam can no longer move. Re-check alignment measurements and adjust if necessary.  
 NOTE: Check to make sure both the adjuster plate and alignment washer are flat against the hanger before final torque is applied.
4. Tighten pivot bolt with a 1"-drive impact wrench and E-20 Torx® socket (Ridewell tool #6100054) until the Torx® head is sheared off.

**CAUTION** Failure to properly torque pivot hardware could result in suspension failure/void the warranty.

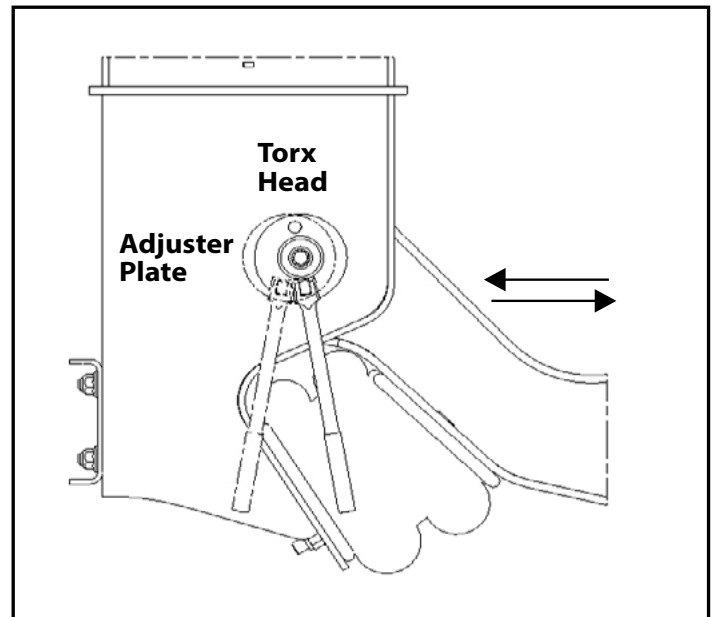

**Figure 11.**  
 Move beam back-and-forth using breaker bar until axle reaches the desired position.

### Figure 12. Kingpin measurement for axle alignment.

**Check forward axle alignment by measuring from the kingpin to both ends of axle centers.**

**If the difference between the "A" measurement and the "B" measurement is greater than 1/8-inch, the forward axle needs to be aligned.**

**Adjust the aft axle if the difference between the "C" measurement and the "D" measurement is greater than 1/16-inch.**

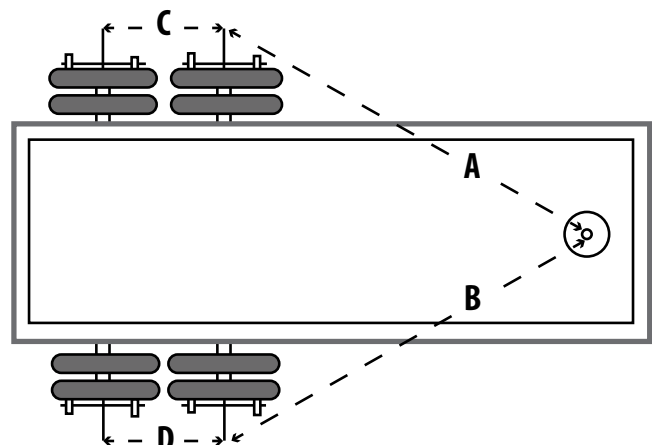

**Terms and coverage in this warranty apply only to the United States and Canada.**

Ridewell Suspensions warrants the suspension systems manufactured by it to be free of defects in material and workmanship. Warranty coverage applies only to suspensions that have been properly installed, maintained and operated within the rated capacity and recommended application of the suspension. The responsibility for warranty coverage is limited to the repair/replacement of suspension parts. The liability for coverage of purchased components is limited to the original warranty coverage extended by the manufacturer of the purchased part.

All work under warranty must have prior written approval from the Ridewell warranty department. Ridewell has the sole discretion and authority to approve or deny a claim and authorize the repair or replacement of suspension parts. All parts must be held until the warranty claim is closed.

Parts that need to be returned for warranty evaluation will be issued a Returned Materials Authorization (RMA). Parts must be returned to Ridewell with the transportation charges prepaid. The transportation charges will be reimbursed if the warranty claim is approved.

This non-transferable warranty is in lieu of all other expressed or implied warranties or representations, including any implied warranties of merchantability or fitness or any obligations on the part of Ridewell. Ridewell will not be liable for any business interruptions, loss of profits, personal injury, any costs of travel delays or for any other special, indirect, incidental or consequential losses, costs or damages.

**Contact the Ridewell Warranty Dept. at 417.833.4565 - Ext. 135, for complete warranty information.**