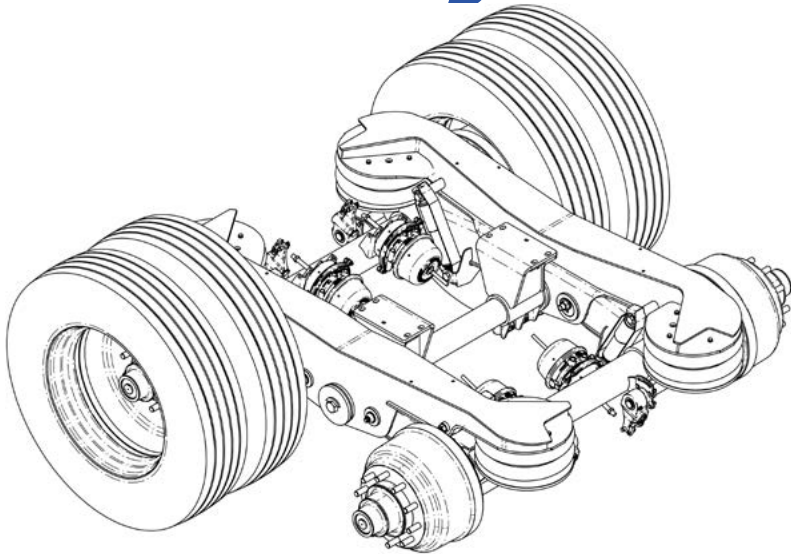


# RAR-254

## *Air Ride Single Point Suspension*



## Installation and Service Manual

<b>Identification</b> .....	<b>2</b>
Suspension Mounting .....	3
HCK Troubleshooting .....	4
<b>Maintenance</b>	
<b>Recommended Service Intervals</b> .....	<b>5</b>
254 Narrow Bushing Components	
Compensator/Trunnion Assembly Components .....	6
254 Wide Bushing Components	
Compensator/Trunnion Assembly Components .....	7
<b>RAR 2540001; 2540003 – Narrow Bushing Replacement</b> .....	<b>9</b>
<b>RAR 2540004 – Wide Bushing Replacement</b> .....	<b>11</b>
<b>RAR-254 Trunnion - Center Bushing Replacement</b> .....	<b>13</b>
<b>Axle Alignment</b> .....	<b>15</b>
<b>Warranty</b> .....	<b>16</b>

**Introduction**

The Ridewell Air Ride 254 Single Point Suspension is available for on-highway and vocational applications. The suspension ships with an integrated 5-inch drum-brake axle.

Refer to the engineering drawing for detailed information on the suspension system components and operating parameters.

**Suspension Identification Tag**

A (606-) **Installation/Assembly Number** will be listed as the **Part Number** when other system components are factory installed with the suspension (Figure 1).

The **Suspension Number** and **Serial Number** on the Suspension ID Tag refer to the model and the date of manufacture of an individual suspension system.

Please refer to the suspension number/part number and serial number on the Suspension Identification Tag when contacting Ridewell for customer service, replacement parts and warranty information.

**Axle-Body Identification Tag**

The **Base-Axle Part Number (165-)** and the **Serial Number** of the axle tube are listed on the Axle-Body ID Tag of Ridewell-branded round axles (Figure 2).

The **Base-Axle Part Number** refers to Ridewell-branded round axles manufactured in various axle wall thicknesses and widths.

More information on Ridewell-branded axles can be found in the "Trailer Axle Parts Guide" (9710029).

**Notes and Cautions**

All work should be completed by a properly trained technician using the proper/special tools and safe work procedures.

Read through the entire Installation and Service Manual (ISM) before performing any procedures.

The ISM uses two types of service notes to provide important safety guidelines, prevent equipment damage and make sure that the suspension system operates correctly.

The service notes are defined as:

"NOTE": Provides additional instructions or procedures to complete tasks and make sure that the suspension functions properly.

**CAUTION** Indicates a hazardous situation or unsafe practice that, if not avoided, could result in equipment damage and serious injury.

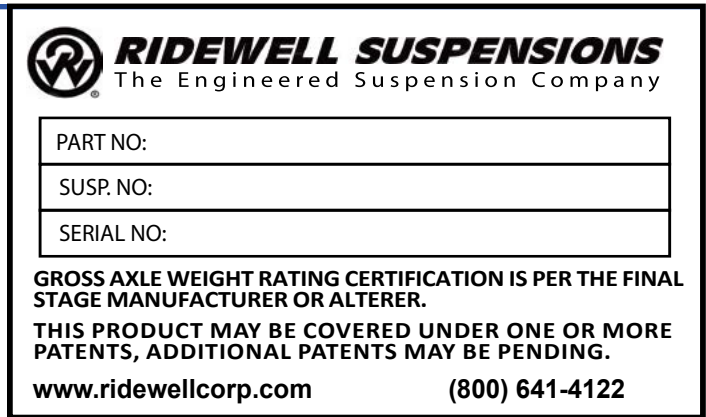


Figure 1.

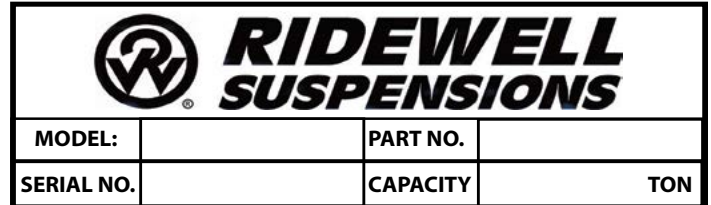


Figure 2.

**Prior to Installation**

- The Gross Axle Weight Rating (GAWR) is determined by the system component with the lowest load rating. Consult tire, wheel, axle and brake manufacturers before installation to determine GAWR.
- If chassis modifications are required, consult vehicle manufacturer to ensure changes are permitted.
- Welding or altering suspension components is not permitted without the express written permission of Ridewell Suspensions.

**Installer Responsibilities**

The installer of the suspension has the sole responsibility for proper attachment of the suspension system to the vehicle chassis.

- The installer is responsible for locating the suspension system to provide proper load distribution.
- The installer must verify that vehicle crossmembers are positioned to support the suspension at the installing location.
- It is the installer's responsibility to determine that axle spacing conforms to any applicable federal and local bridge laws.
- The installer must verify air reservoir volume requirements are met after installation. Consult the vehicle manufacturer or Federal Motor Vehicle Safety Standards 121 for more information.
- The installer must verify there is sufficient clearance for proper functioning of the suspension, air springs, brake chambers, axle and tires.

## Suspension Mounting

Refer to the engineering drawing for the suspension travel table; the recommended bolt-hole locations for suspension mounting; and, the suspension spacing and clearance requirements.

Main pivot fasteners are shipped with minimal torque applied. It is the installer's responsibility to properly torque fasteners after the axle(s) is aligned.

The suspension installer has the final responsibility of attaching the suspension to the vehicle frame.

### Installation Procedure

Grade-8 bolts, flanged locknuts or locknuts with hardened washers are supplied by the installer.

**CAUTION** Check to make sure that wires, hoses or other components located within the frame rail are not affected by drilling. Check the location for necessary clearances.

1. Bolt the trunnion hangers to the mounting brackets or trailer frame. Tighten bolts until hanger plate is resting on mounting bracket/trailer frame, but suspension location can still be adjusted. Do not apply final torque.
2. Align the trunnion tube with the kingpin. Trunnion alignment dimensions "T1" and "T2" shown on the illustration must be equal (Figure 3).
3. Tighten the trunnion hanger fasteners to specification. Check trunnion alignment and realign trunnion tube if necessary.
4. Using 1/2" -drive breaker bar, rotate front axle beam alignment plate in the opposite direction of desired axle movement. Make sure that the alignment plate and alignment washer have moved in unison. It is important that the pivot bushing is not skewed in the hanger prior to tightening.
5. Check that axle alignment dimensions "A" and "B" are equal to  $\pm 1/8"$ . Snug the four pivot fasteners and recheck the alignment (Figure 3).
6. Repeat alignment process on the rear axle, ensuring that rear axle alignment dimensions "C" and "D" are equal to  $\pm 1/16"$ .
7. Check dimension "E"- the lateral centerline relationship of the trailer body and axles. "E" dimension must not exceed 1/4-inch.
8. Recheck the alignment of the front axle with the kingpin. Recheck alignment of the rear axle with the front axle.

9. After trunnion and axle alignments have been completed, torque the four pivot bolts using a 1" drive impact wrench and #6100054 E-20 Torx socket (or equivalent) until the Torx head shears off from the bolt.

NOTE: Check the Torx head shear-off. Remove any rough or jagged fragments so that the round pivot bolt head is completely smooth.

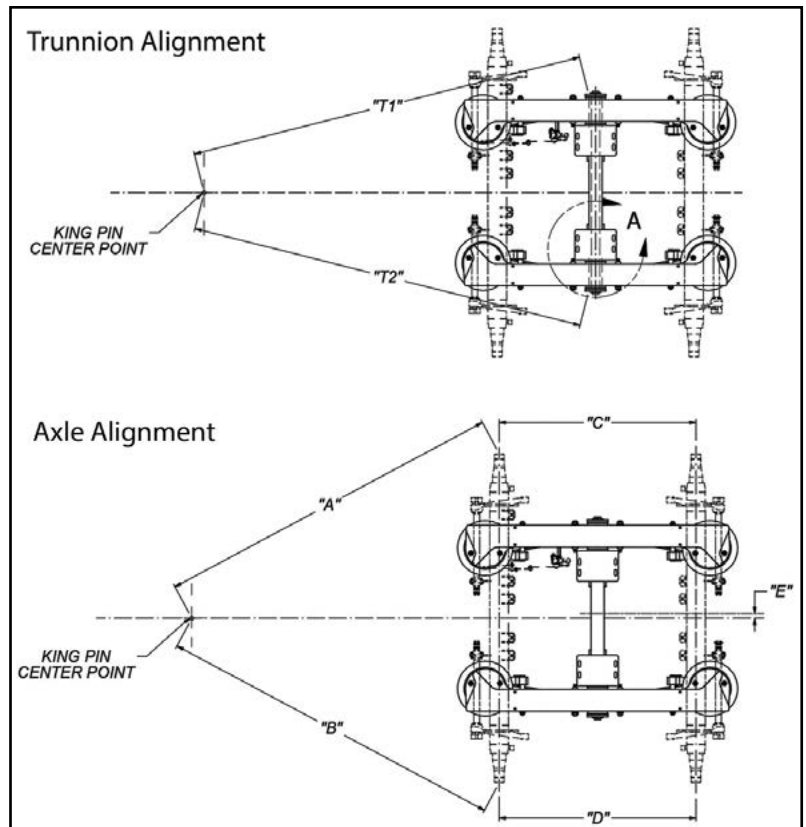
10. Weld the trunnion hanger to the mounting bracket or trailer frame and frame member with a 5/16" fillet weld.

NOTE: Welding the adjuster plates or the alignment washers to the hanger sidewalls is not required or recommended.

Install/connect the height control kits on the compensator/trunnion assembly. Check the air system tubing and fittings after installation for leaks (Page 4).

**CAUTION** Failure to torque bolts/nuts of suspension components to specifications can result in failure of the suspension and void the warranty.

**CAUTION** Welding method must use a minimum weld tensile strength of 70,000 psi per AWS specifications.

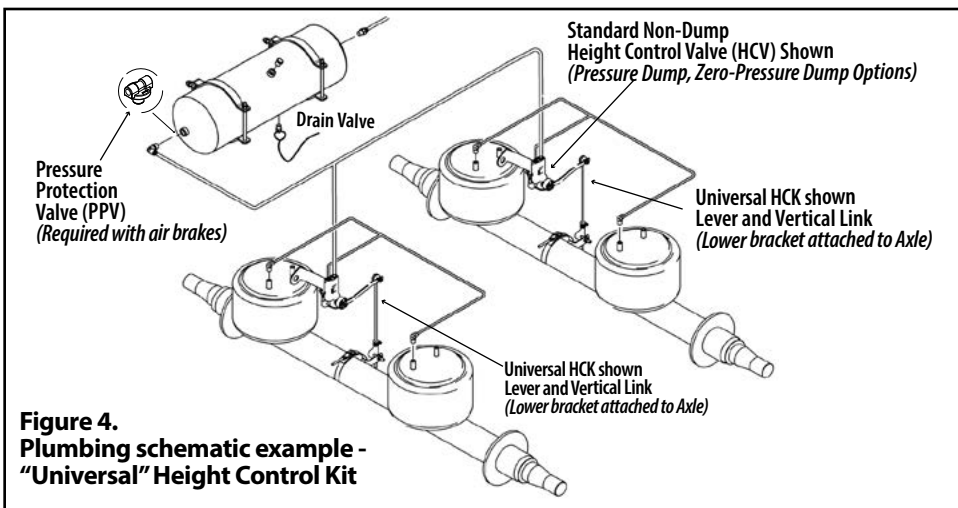
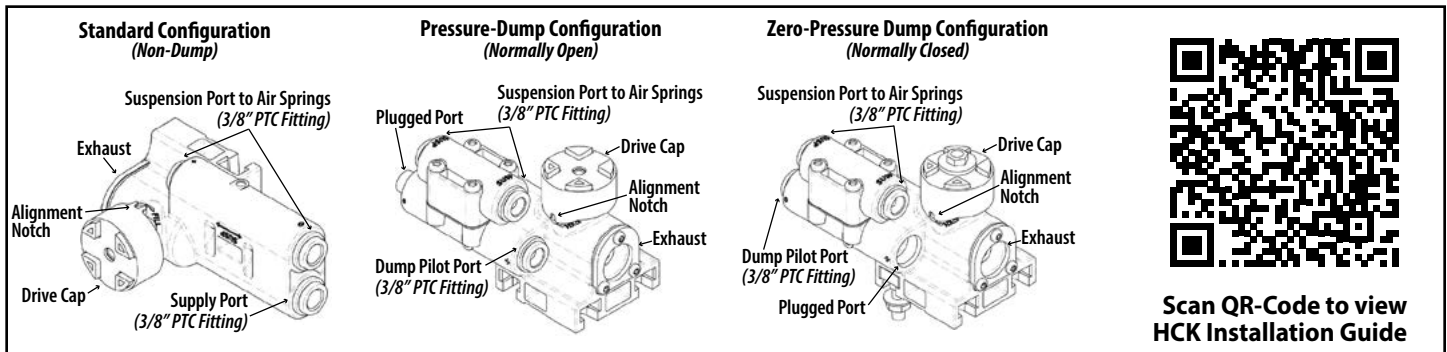


**Figure 3.**  
Kingpin measurements for trunnion and axle alignment.

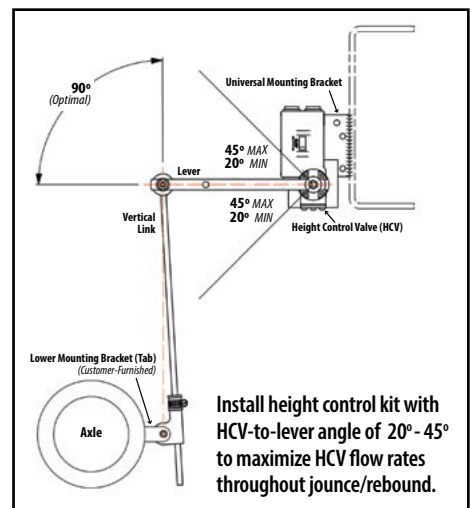
The Ridewell Extreme Air® Height Control Kit (HCK) adds and exhausts air from the air springs to maintain vehicle ride height. The HCK assembly consists of one lever connected to the height control valve (HCV) with a rod arm (vertical link) connected to the lower mounting bracket (Fig. 5).

Refer to Installation Guide 9710008 for installation procedures and HCK configurations for different suspension applications. The vehicle's entire air system should be checked for leaks after any height control kit installation.

**CAUTION** The installer is responsible for making sure that the air system requirements comply with all appropriate Federal Motor Vehicle Safety Standards.



**Figure 4.**  
Plumbing schematic example -  
"Universal" Height Control Kit



Install height control kit with HCV-to-lever angle of 20° - 45° to maximize HCV flow rates throughout jounce/rebound.

**HEIGHT CONTROL KIT INSTALLATION – TROUBLESHOOTING**

Problem	Possible Cause	Corrective Action
HCV is not receiving air.	<ul style="list-style-type: none"> <li>Blocked air supply line.</li> </ul>	<ul style="list-style-type: none"> <li>Verify air lines are pressurized by removing supply line at HCV. Check for pinched lines.</li> </ul>
HCV is not delivering air to the air springs.	<ul style="list-style-type: none"> <li>Air tank not filling/reaching set pressure.</li> <li>Pressure Protection Valve (PPV) not working correctly.</li> <li>Pilot port is not plumbed or is plumbed incorrectly.</li> </ul>	<ul style="list-style-type: none"> <li>Verify air tank pressure with manual/in-line pressure gauge.</li> <li>Check PPV operation by making sure valve opens when system reaches the desired pressure setpoint (<i>usually greater than 70 psi</i>).</li> <li>Check HCV configuration and reinstall if necessary – Non-Dump; Pressure-Dump (Normally Open); Zero-Pressure Dump (Normally Closed).</li> </ul>
Air springs fill but do not exhaust.	<ul style="list-style-type: none"> <li>Obstructed air line.</li> <li>HCV installed backwards.</li> <li>Supply line installed to suspension port</li> </ul>	<ul style="list-style-type: none"> <li>Disconnect linkage. Rotate lever to down position (exhaust). If springs remain inflated, check for pinched/blocked lines.</li> <li>Check installation. Reinstall, if necessary.</li> <li>Move air supply line to HCV supply port.</li> </ul>
Air system leaks down in a short period of time.	<ul style="list-style-type: none"> <li>HCV installed backwards.</li> <li>Leak in air system beyond accepted standards.</li> </ul>	<ul style="list-style-type: none"> <li>Disconnect linkage to HCV. Turn lever to the up position (fill). If air springs do not inflate, reinstall height control valve. Check air system for leaks.</li> <li>To find leak in the HCV area, pressurize system and spray soapy water solution onto the valve and lines. Check for bubbles (leaks): No leak found – Do not remove valve, check rest of system for leaks. Check that tubing cuts are straight and smooth. Re-cut and reassemble if necessary.</li> </ul>



**Recommended Service Intervals**

Ridewell Suspensions recommends the following minimum service intervals for standard duty, on-highway usage applications. More frequent intervals are recommended for heavier duty applications.

Refer to these Technology & Maintenance Council (TMC) publications for additional information	
RP 609	Self-Adjusting/Manual Brake Adjuster Removal, Installation and Maintenance
RP 618	Wheel Bearing Adjustment Procedure
RP 619	Air System Inspection Procedure
RP 622	Wheel Seal and Bearing Removal, Installation, and Maintenance
RP 631	Wheel End Lubrication Recommendations
RP 643	Air Ride Suspension Maintenance
RP 728	Trailer Axle Maintenance

**Daily/Pre-Trip Inspections**

- \_\_\_ Check tires for proper inflation, damage or excessive wear.
- \_\_\_ Check wheel-ends for obvious signs of lubricant leakage. Check for missing components.
- \_\_\_ Check axle assemblies for damage or loose components.
- \_\_\_ Visually inspect suspension structure for signs of damage or excessive wear.
- \_\_\_ Check for loose or missing bolts/nuts. Check for irregular movement in suspension components.
- \_\_\_ Make sure air controls are operating properly. Drain all moisture from air reservoirs.

**First 6,000 miles of use**

- \_\_\_ Torque suspension components to specifications (Page 11/Engineering Drawing).  
NOTE: Do not re-torque shear-type pivot bolt.
- \_\_\_ Verify suspension operating at installed ride height.

**Every 12,000 miles of use**

- \_\_\_ Inspect air springs for damage/excessive wear. Torque air spring bolts/nuts to specifications (Page 11/Engineering Drawing).
- \_\_\_ Check air lines and connections for leaks.

**Every 50,000 miles of use**

- \_\_\_ Torque suspension components to specifications (Page 11/Engineering Drawing).  
NOTE: Do not re-torque shear-type pivot bolt.

**Annually/100,000 miles of use**

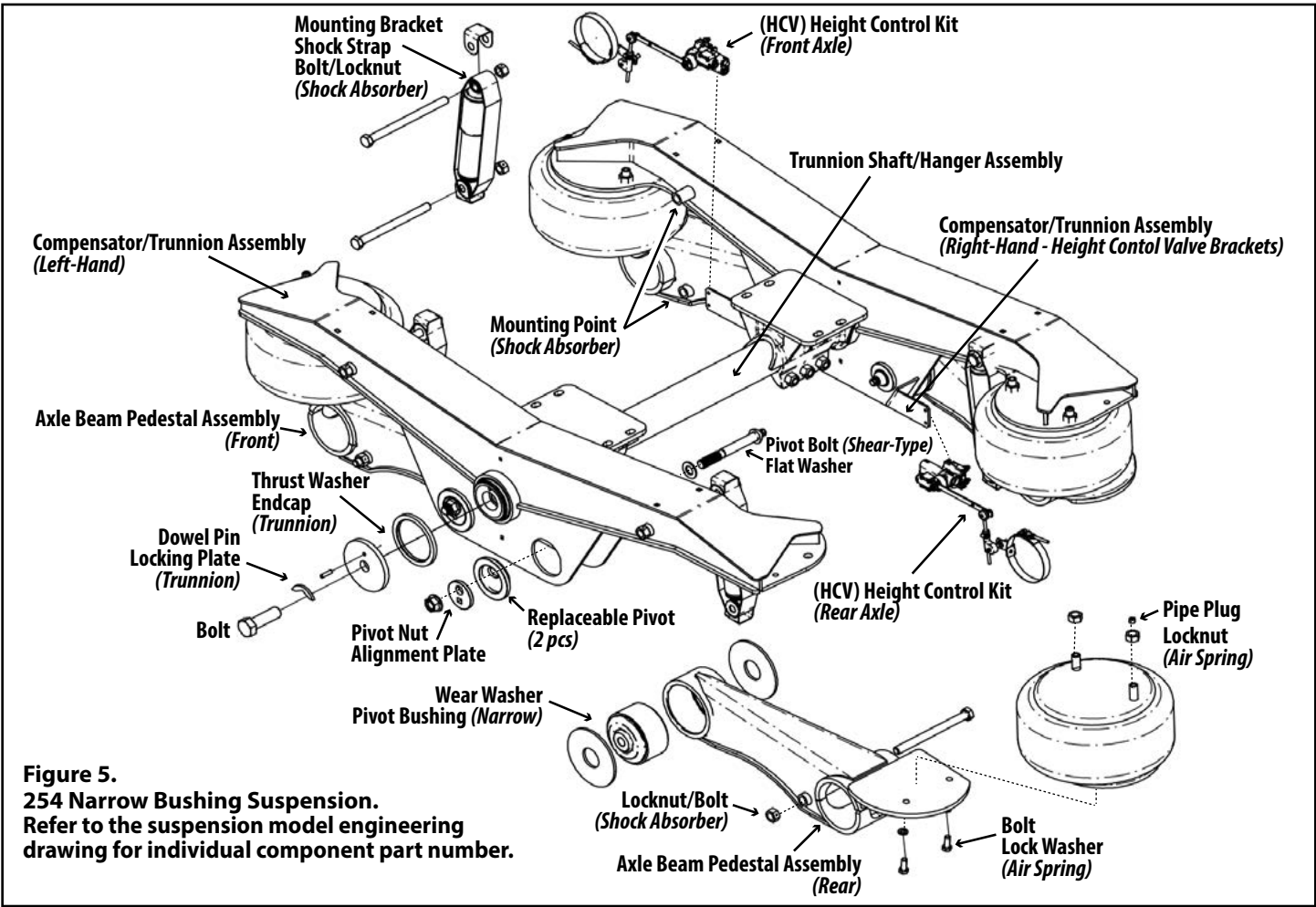
- \_\_\_ Inspect pivot connection for worn pivot bushing and wear washers. Replace if necessary.
- \_\_\_ Torque component bolts/nuts to specifications (Page 11/Engineering Drawing).
- \_\_\_ Check arm beam-to-axle connection welds.

**Check lubrication level in wheel ends:**

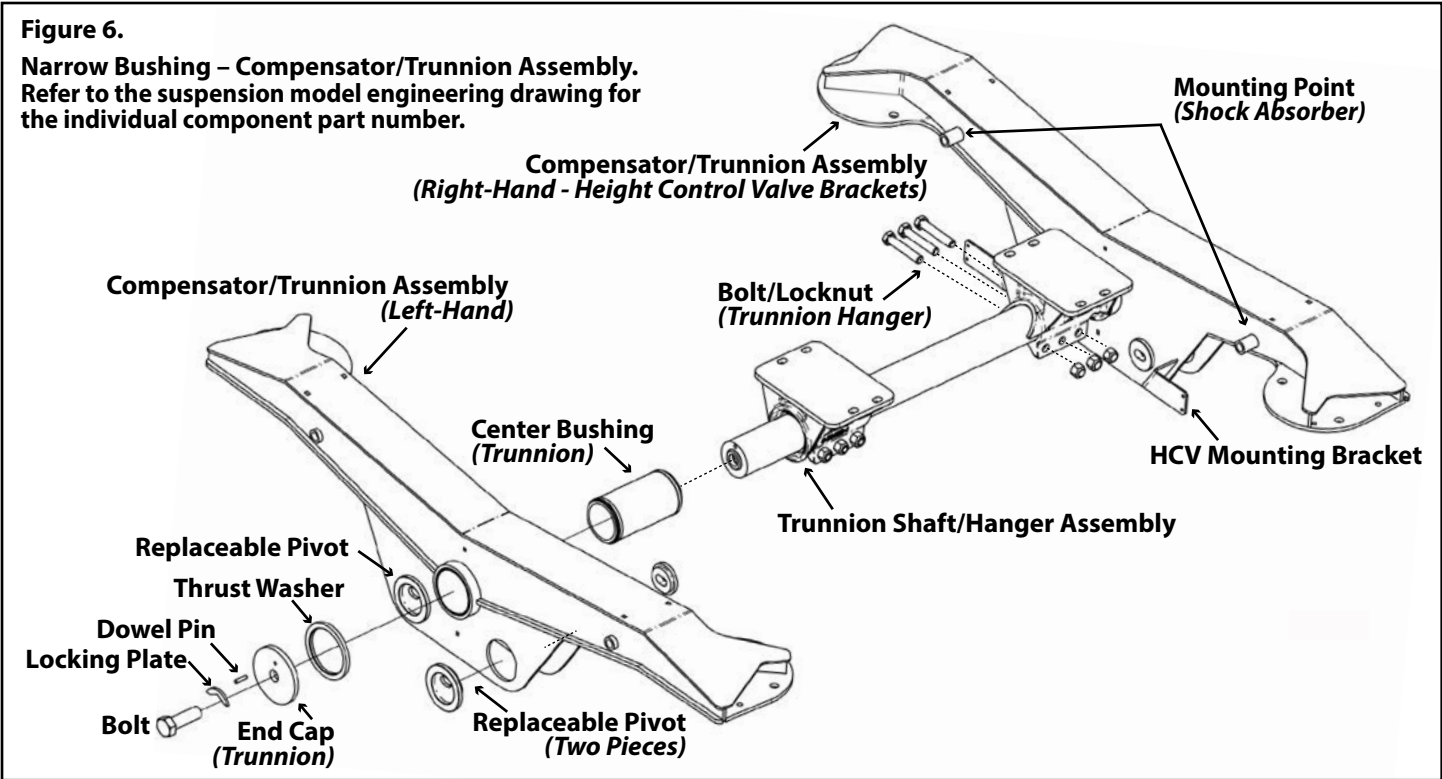
- \_\_\_ 1) Oil-Filled Wheel Ends:  
Refill/Replace lubricant as needed (TMC RP 631-“100K/Annual Inspection”).
- \_\_\_ 2) Semi-Fluid Grease:  
Pull outer bearing and visually inspect the lubrication level. Refill/Replace as needed (TMC RP 631-“Level 3 Lubrication Level Inspection”) (TMC RP 618-“Wheel Bearing Adjustment”).

- \_\_\_ Check air lines and connections for leaks.
- \_\_\_ Test air control system pressure protection valve (PPV), if equipped.
- \_\_\_ Check height control valve (HCV) adjustment.
- \_\_\_ Verify suspension operating at installed ride height.

**CAUTION** Failure to torque suspension components to specifications can result in suspension failure and void the warranty.

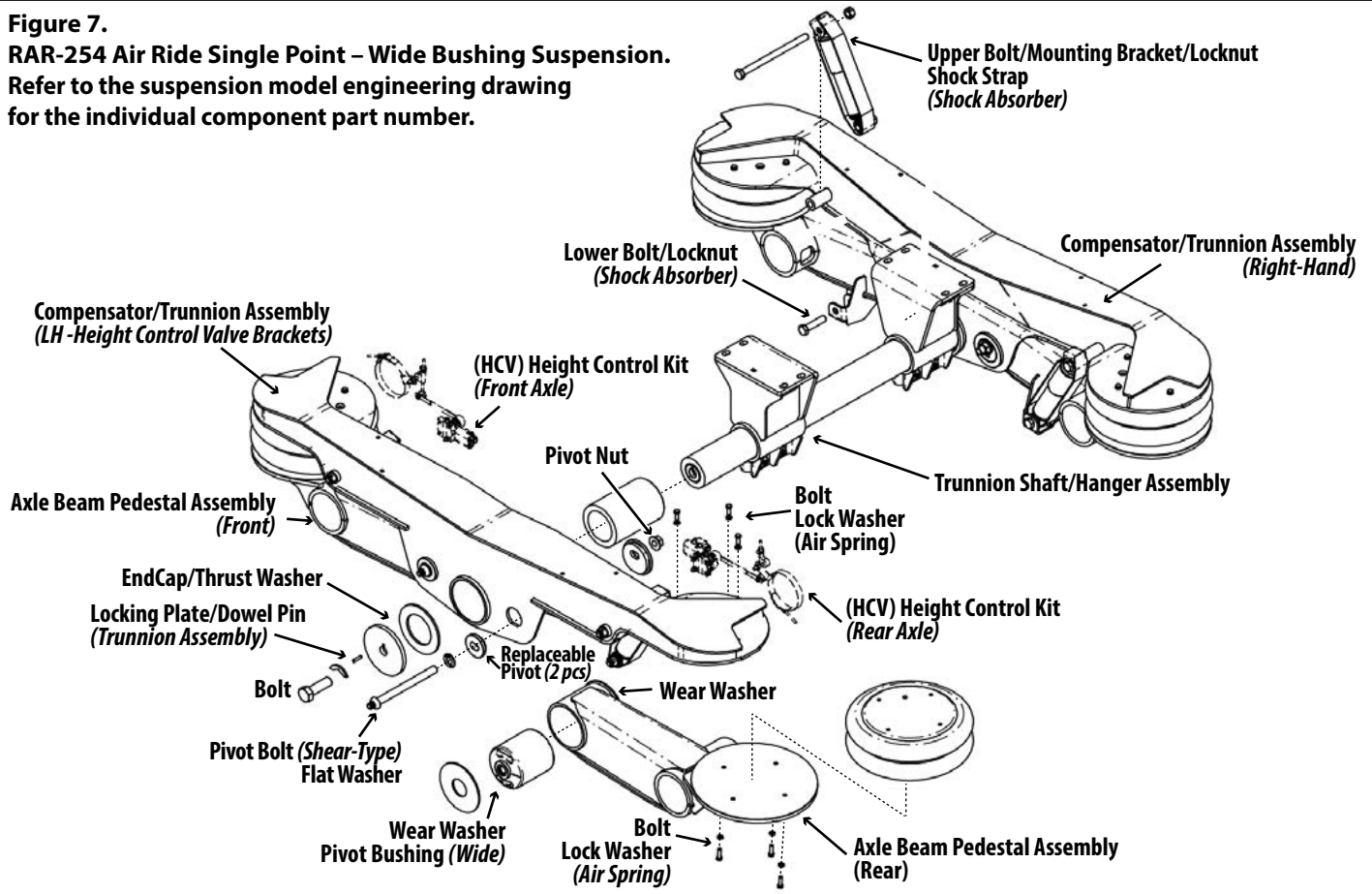


**Figure 5.**  
**254 Narrow Bushing Suspension.**  
 Refer to the suspension model engineering drawing for individual component part number.

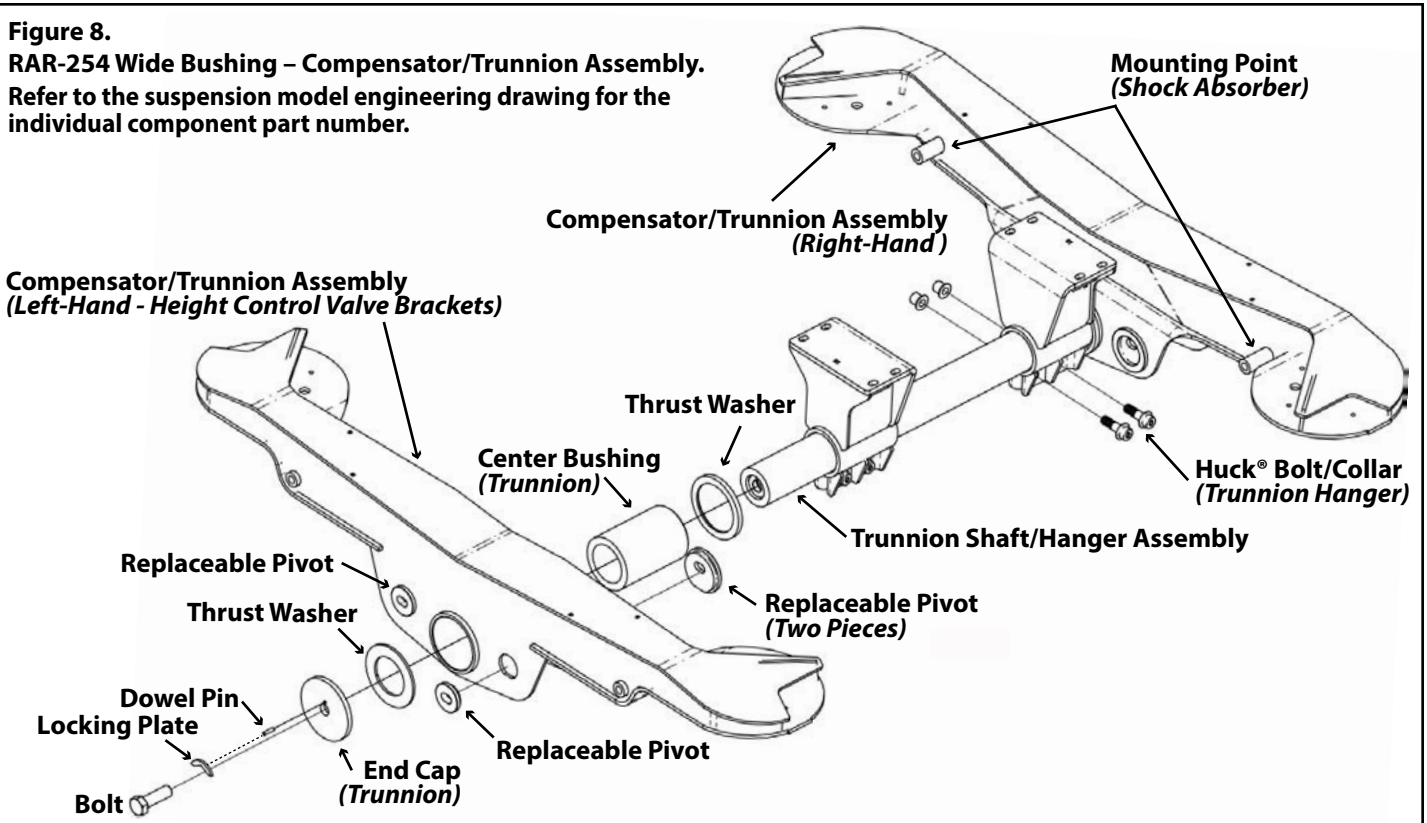


**Figure 6.**  
**Narrow Bushing - Compensator/Trunnion Assembly.**  
 Refer to the suspension model engineering drawing for the individual component part number.

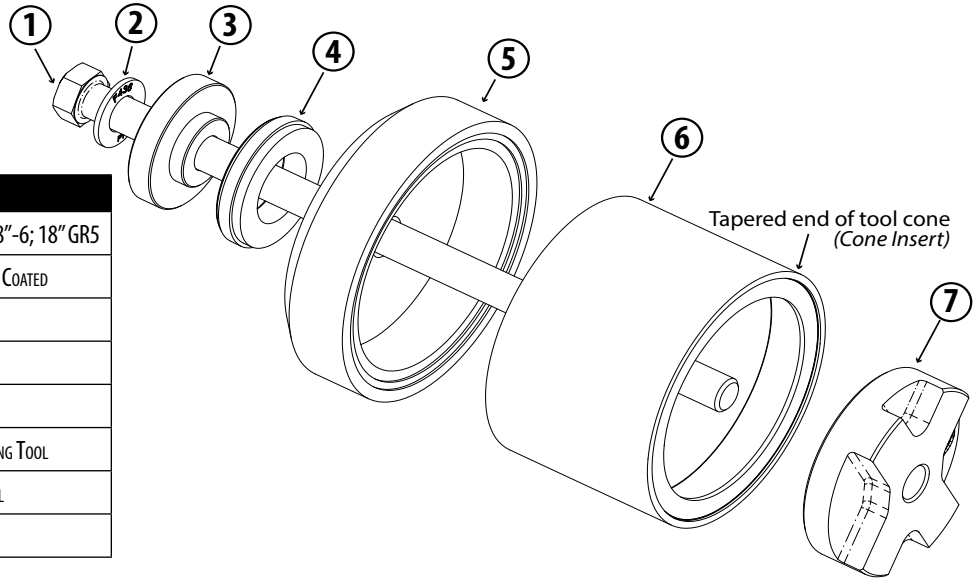
**Figure 7.**  
**RAR-254 Air Ride Single Point – Wide Bushing Suspension.**  
 Refer to the suspension model engineering drawing  
 for the individual component part number.



**Figure 8.**  
**RAR-254 Wide Bushing – Compensator/Trunion Assembly.**  
 Refer to the suspension model engineering drawing  
 for the individual component part number.

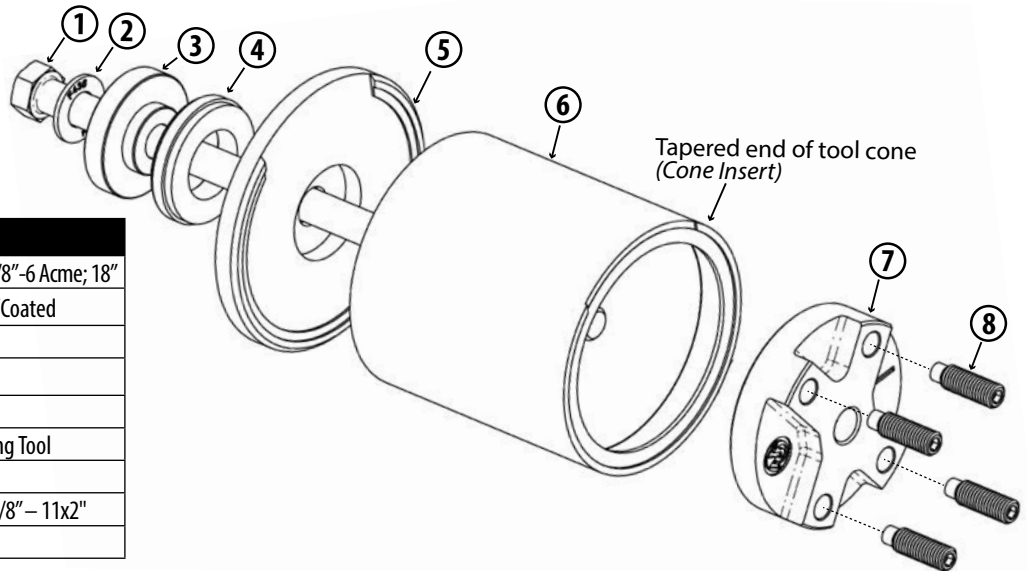


**Figure 9.**  
**Bushing Tool #6100044**



No	Part No.	Item Description
1	1130088	Hex Head Cap Screw (HHCS) 7/8"-6; 18" GR5
2	1160036	Flat Washer - 7/8" F436 ZINC COATED
3	1120051	BEARING COLLAR
4	1660009	THRUST BEARING
5	6100089	ENDCAP - NARROW BUSHING TOOL
6	6100092	CONE ASSEMBLY - NARROW BUSHING TOOL
7	6100091	PLUNGER - NARROW BUSHING TOOL
—	1980014	EXTREME PRESSURE LUBRICANT

**Figure 10.**  
**Bushing Tool #6100051**



No.	Part No.	Item Description
1	1130088	Hex Head Cap Screw (HHCS) - 7/8" - 6 Acme; 18"
2	1160036	Flat Washer 7/8" - F436 Zinc/Coated
3	1120051	Bearing Collar - Bushing Tool
4	1660009	Thrust Bearing
5	6100086	End Cap - Wide Bushing Tool
6	6100083	Cone Assembly - Wide Bushing Tool
7	6100087	Plunger - Wide Bushing Tool
8	1130087	Cavity Alignment Stud (SHCS) 5/8" - 11x2"
—	1980014	Extreme Pressure Lubricant



**2540001; 2540003 Air Ride Single Point Suspension – Narrow Bushing Replacement/Torque Specifications**

Part Number (Component)	Item Description	Size	Torque Values (foot-pound Newton-meter)	
<b>6040194-Bushing Kit</b> <b>6100044-Narrow Tool</b>	<b>Pivot Bolt/Nut - (Shear-Type Bolt/Locknut)</b> <i>Requires E-20 Torx® socket (RW #6100054)</i>	7/8"-9NC	<i>Do not lubricate bolt/nut threads. Use 1"-drive impact wrench to tighten until Torx® head shears off.</i>	
<b>Fasteners</b>	<b>Shock Absorber Bolt (HHCS)</b>	3/4"- 10NC	200-230 ft-lb	271-312 N-m
	<b>Air Spring Nut, Upper</b>	3/4"- 16NF	45-50 ft-lb	61-68 N-m
	<b>Air Spring Bolt, Lower</b>	1/2"- 13NC	45-50 ft-lb	61-68 N-m
	<b>Trunnion Bushing Bolt</b>	1 1/8"- 12NC	500 ft-lb	678 N-m

*Torque values reflect a lubricated thread condition (Nuts are pre-lubed). Do not overtorque.*

**CAUTION** Suspension is shipped with minimal torque applied to fasteners. All fasteners must be re-torqued after first 6,000 miles of operation. Failure to install and maintain fasteners at torque specifications could result in suspension failure and void the warranty.

**Vehicle Preparation**

Park vehicle on a level surface. Chock wheels.

Raise vehicle to a height that removes the load on the suspension. Support with jack stands.

Disconnect the linkage from the height control valve(s), if equipped. Exhaust all air from the system.

**CAUTION** Failure to properly chock wheels, exhaust the air system and safely support the vehicle could allow vehicle/suspension movement that could result in serious injury.

**Disassemble the suspension**

Remove wheels and tires, if necessary. Remove the shock absorbers.

Take the pivot connections apart. Remove and discard pivot bolt, flat washer and pivot nut.

Inspect adjuster plate and alignment washer for wear/damage. Replace if necessary.

**CAUTION** Do not reuse pivot hardware.

Rotate beams down and away from frame. Inspect pivot-bolt holes and wear washers for unusual wear/damage. Repair or replace components as needed.

**Tool Assembly**

Check that thrust bearing is installed in the flat, outside edge of endcap. Inspect tapered insert and endcap for damage. Repair or replace as needed.

Lubricate Hex-Head Cap Screw and thrust bearing threads with Extreme Pressure Lubricant (#1980014).

Thread the flat washer, the bearing collar and the endcap onto the HHCS until the bearing collar and endcap rest against the head of the HHCS. Place tool cone onto endcap (Figure 11).

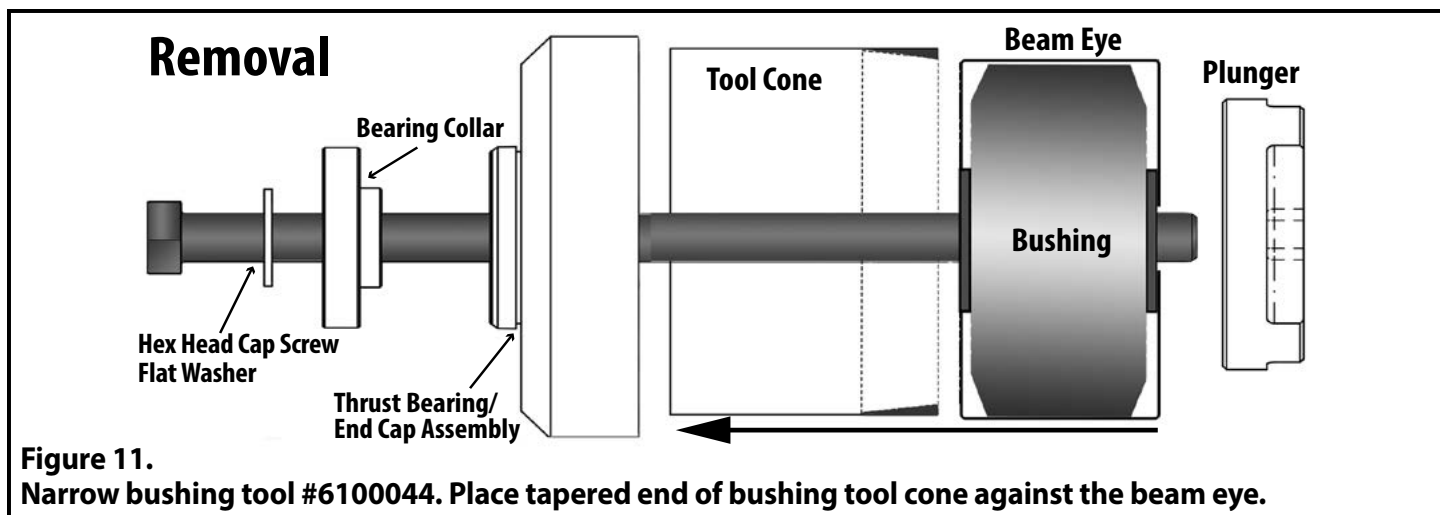
NOTE: Failure to apply lubricant to the threads could result in decreased tool performance and reduce the life of the bushing tool.

**Bushing Removal**

1. Push the hex-head cap screw through the bushing inner sleeve until the tool cone is against the beam eye. Thread the plunger onto the HHCS until the tool cone is held firmly against the beam (Figure 11).

NOTE: The smaller, tapered end of the cone is placed against the beam eye for both removal and installation of the bushing.

*continued on next page*



**Figure 11.**  
**Narrow bushing tool #6100044. Place tapered end of bushing tool cone against the beam eye.**

## Replacement Procedure with Narrow Bushing Tool #610044 (continued)

2. Check that tool cone is centered on the beam eye. Use a 1 5/16" socket on a 3/4"-drive impact wrench (1"-drive impact wrench recommended) to rotate HHCS to pull bushing into the cone. NOTE: In some cases, a small amount of heat may be needed to break the bond between the bushing and beam eye. Do not overheat. Allow the beam to cool before installing replacement bushing.
3. Remove bushing tool from the beam. Detach tool cone from endcap, remove bushing and discard

### Tool Assembly

Thread the flat washer, the bearing collar and the endcap onto the hex-head cap screw until the bearing collar and endcap rest against the head of the HHCS.

### Bushing Installation

1. Use wire brush to clean debris /corrosion from eye.
2. Liberally apply P80<sup>®</sup> lubricant or a soap solution to the inside of the beam eye, the outside of the new bushing and inside the tool cone. Insert new bushing into the larger opening of the tool cone (Figure 12).
3. Center the smaller opening of the tool cone against beam eye. Push the hex-head cap screw through the bushing inner sleeve from the opposite side of the beam until the endcap rests against the beam eye.
4. Thread the plunger onto the hex-head cap screw until tool cone is held firmly against the beam. NOTE: The smaller opening of the tool cone is placed against the beam eye for both removal and installation of the bushing.

5. Check that bushing tool cone is centered on the beam eye. Use a 1 5/16" socket and 3/4"-drive impact wrench (1"-drive impact wrench recommended) to rotate the hex-head cap screw and press bushing into the beam eye.
6. Remove bushing tool from the beam. Check that bushing is centered inside the beam. Realign bushing if necessary.

### Reassemble suspension

Rotate the beams into hangers. Assemble the pivot connection – alignment washer, adjuster plate, wear washers, shear-type pivot bolt, flat washer and flanged locknut.

NOTE: Do not lubricate pivot bolt/nut.

Tighten locknut until adjuster plate pin is engaged and pivot connection hardware is snug against the hanger. Do not apply final torque until the axle alignment has been checked.

Connect the height control valve linkage (if linkage has been disconnected). Inflate air springs.

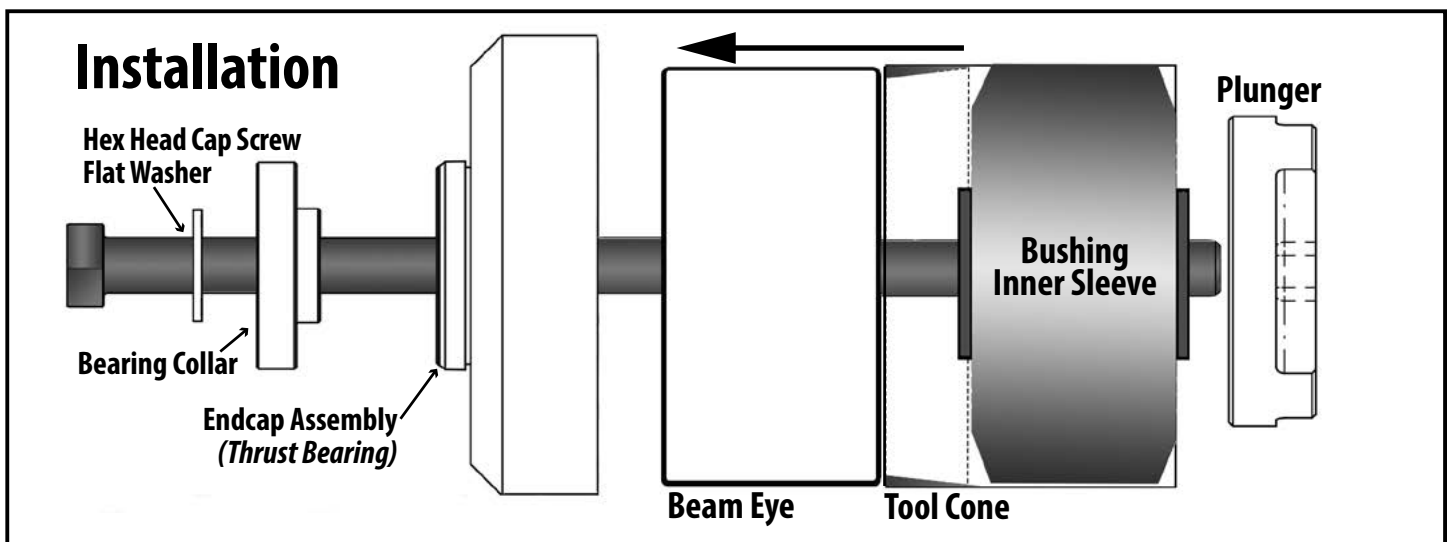
Install wheels and tires (if removed). Raise the vehicle and remove support stands. Lower vehicle to ground.

Verify suspension ride height. Check axle alignment. Realign if necessary (Pg 15).

Tighten pivot bolt with a 1" drive impact wrench and E-20 Torx<sup>®</sup> socket (Ridewell tool #6100054) until Torx<sup>®</sup> head is sheared off.

Install shock absorbers.

**CAUTION** Failure to torque hardware to specifications can result in suspension failure/void the warranty.



**Figure 12.**  
**Narrow bushing tool #610044.**  
**The tapered cone expands the bushing during removal and compresses the bushing during installation.**

## 2540004 Air Ride Single Point Suspension – Wide Bushing Replacement/Torque Specifications

Part Number (Component)	Item Description	Size	Torque Values (foot-pound Newton-meter)	
<b>6040098-Bushing Kit</b> <b>6100051-Wide Tool</b>	<b>Pivot Bolt/Nut - (Shear-Type Bolt/Locknut)</b> <i>Requires E-20 Torx® socket (RW #6100054)</i>	7/8"-9NC	<i>Do not lubricate bolt/nut threads. Use 1"-drive impact wrench to tighten until Torx® head shears off.</i>	
<b>Fasteners</b>	<b>Shock Absorber Bolt/Nut</b>	3/4"- 10NC	200-230 ft-lb	271-312 N-m
	<b>Air Spring Bolt - Upper; Lower</b>	3/8"- 16NC	20-25 ft-lb	27-34 N-m
	<b>Trunnion Bushing Bolt</b>	1 1/8"- 12NC	500 ft-lb	678 N-m

Torque values reflect a lubricated thread condition (Nuts are pre-lubed). Do not overtorque.

**CAUTION** Suspension is shipped with minimal torque applied to fasteners. All fasteners must be re-torqued after first 6,000 miles of operation. Failure to install and maintain fasteners at torque specifications could result in suspension failure and void the warranty.

### Vehicle Preparation

Park the vehicle on a level surface. Chock wheels. Raise vehicle to a height that removes the load from the suspension. Support with jack stands.

Disconnect the linkage from the height control valve(s), if equipped. Exhaust all air from the system.

**CAUTION** Failure to properly chock wheels, exhaust the air system and safely support the vehicle could allow vehicle movement that results in serious injury.

### Disassemble the suspension

Remove wheels/tires. Remove shock absorbers.

Take the pivot connections apart. Remove and discard pivot bolt, flat washer and pivot nut.

Inspect the adjuster plate and the alignment washer for wear/damage. Replace if necessary.

**CAUTION** Do not reuse pivot hardware.

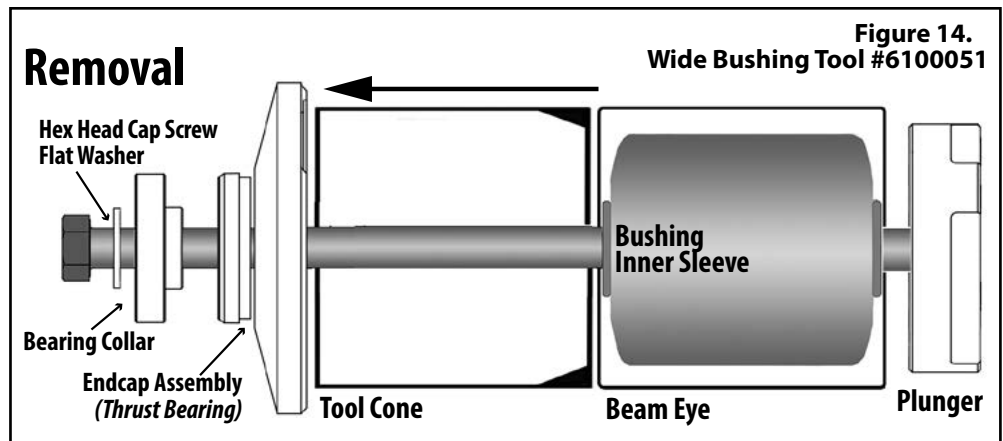
Rotate beams out of the hangers. Inspect pivot-bolt holes and hanger surfaces for unusual wear/damage. Repair or replace suspension components as needed.

### Tool Assembly

Make sure thrust washer is seated firmly in flat (outside) edge of the endcap. Examine the tool cone tapered insert and large end for damage/out-of-round. Repair or replace as necessary (Fig 14).

### Bushing Removal

1. Draw/scribe line on the beam using the locator mark on installed bushing as the reference (Figure 13).
2. Lubricate HHCS threads and thrust washer bearings with Extreme Pressure Lube (P/N 1980014).  
NOTE: Failure to apply lubricant could result in decreased performance and reduced tool life.
3. Place flat washer onto HHCS, followed by the bearing collar and endcap assembly.



**Figure 14.**

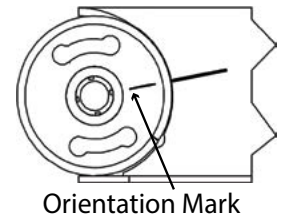
**Wide Bushing Tool #6100051**

4. The bushing tool cone is tapered inside to a smaller opening on one end. Place the larger opening of the cone onto the endcap. NOTE: The tapered end of tool cone is placed on the eye of the beam for removal/installation.

**Figure 13.**

### (Wide) Bushing Orientation

Draw Reference Line on Beam Before Bushing is Removed



5. Insert the end of the hex bolt through the bushing sleeve into the center opening of plunger. Center cone on the beam eye. Tighten the hex bolt until plunger is held firmly against the bushing.
6. Use a 1 5/16" socket on a 3/4"-drive impact wrench (1"-drive impact wrench recommended) to rotate hex bolt and press bushing out of the beam eye into the tool cone.  
NOTE: In some cases, a small amount of heat may be required to break the bond between the bushing and the beam eye. Do not overheat. Allow the beam to cool before installing replacement bushing.
7. Disassemble the bushing tool. Remove the old bushing from the bushing tool cone and discard.

*continued on next page*

## Replacement Procedure with Wide Bushing Tool #610051 (continued)

### Tool Assembly-Installation

Place flat washer, the bearing collar, and the end-cap assembly on the hex-head bolt.

Insert the smooth end of each Cavity Alignment Stud (Socket Head Cap Screw-SHCS) into the four holes on the outside edge of the bushing tool plunger.

Tighten the alignment stud(s) until the socket head is flush with the edge of the plunger.

NOTE: The smooth ends of the studs should extend beyond the inside edge of the plunger (Figure 15).

### Bushing Installation

1. Use a wire brush to clean foreign debris and corrosion out of the beam eye.
2. Coat the inside of the beam eye, the outside of the bushing and the inside of the tool cone with S.G. Type "M" Rubber Assembly Oil.  
NOTE: Do not substitute lubricant. Type "M" Oil included with all bushing replacement kits.
3. Insert the replacement bushing into the large end of the tool cone. Make sure the locator mark on the new bushing is visible.
4. Line up locator mark on tool plunger with the locator mark on the bushing. Insert the four cavity alignment studs into the bushing cavity holes and press plunger firmly against the end of the bushing.  
NOTE: The stud threads should NOT touch the bushing. Reinstall studs if necessary (Figure 15).
5. Align plunger locator mark with the line drawn on the beam. Place the plunger/cone/bushing assembly onto the beam eye.
6. Insert the hex-head bolt assembly through the beam eye. Thread the hex bolt into the plunger until the endcap rests against the beam.

7. Center the bushing tool cone on the beam eye. Use a 1 5/16" socket and 3/4-drive impact wrench (1"-drive impact wrench recommended) to rotate the hex-head cap screw and press bushing into the beam eye.
8. Disassemble and remove the bushing replacement tool. Check placement to make sure bushing is centered in the beam.
9. Check bushing locator mark against the line drawn on beam to make sure new bushing is properly oriented.

### Reassemble suspension

Rotate the beams into hangers. Assemble pivot connection—alignment washer, adjuster plate, wear washers, shear-type pivot bolt, flat washer and locknut.

NOTE: Do not lubricate pivot bolt/nut. Tighten flanged locknut until adjuster plate pin is engaged and pivot connection hardware is snug against hanger. Do not apply final torque until axle alignment has been checked.

Connect height control valve linkage (if linkage has been disconnected). Inflate air springs.

Install wheels and tires (if removed). Raise vehicle and remove support stands. Lower vehicle to ground. Verify suspension ride height. Check axle alignment. Realign if necessary (Page 15).

Tighten pivot bolt with a 1" drive impact wrench and E-20 Torx® socket (Ridewell tool #6100054) until Torx® head is sheared off.

Install shock absorbers.

**CAUTION** Failure to torque hardware to specifications can result in suspension failure and void the warranty.

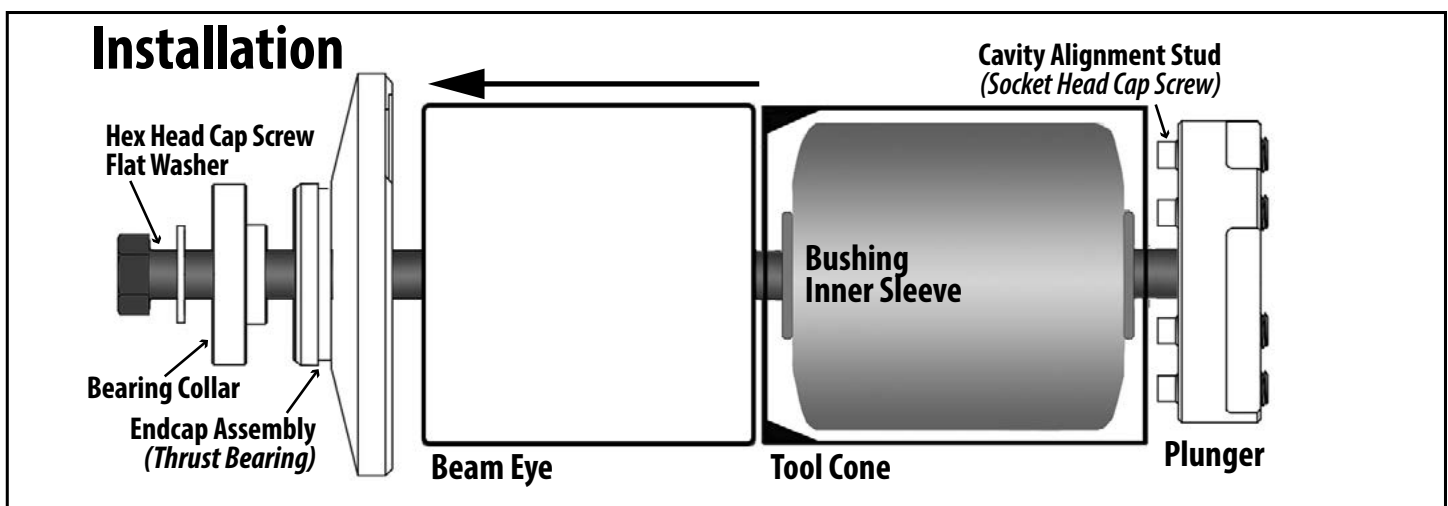


Figure 15.

Wide Bushing Tool #610051. Tapered end of tool cone placed against the beam eye for installation.



Part No.	Item Description	Torque Values – foot-pound; Newton-meter	
<b>1120049</b>	<b>Trunnion-Center Bushing</b>	<b>Narrow Bushing Suspension</b>	
<b>1143773B105</b>	Trunnion Shaft Bolt (HHCS) 1-1/8" -12NF (Grade 5)	500 ft-lb	678 N-m
<b>1130048</b> <b>1150067</b>	Pivot Bolt - Shear-Type Pivot Nut (Flanged Locknut)	<i>Do not lubricate bolt/nut threads. Use 1"-drive impact wrench to tighten until Torx® head shears.</i>	
<b>1120048</b>	<b>Trunnion-Center Bushing</b>	<b>Wide Bushing Suspension</b>	
<b>1143773B105</b>	Trunnion Shaft Bolt (HHCS) 1-1/8" -12NF (Grade 5)	500 ft-lb	678 N-m
<b>1130031</b> <b>1150067</b>	Pivot Bolt - Shear-Type Pivot Nut (Flanged Locknut)	<i>Do not lubricate bolt/nut threads. Use 1"-drive impact wrench to tighten until Torx® head shears.</i>	

**CAUTION** Failure to install and maintain fasteners at torque specifications could result in suspension failure and void the warranty. Refer to the suspension model engineering drawing for torque values.

## Vehicle Preparation

Park the vehicle on a level surface. Chock wheels to keep vehicle from moving.

Raise vehicle to height that removes load from suspension and support with jack stands.

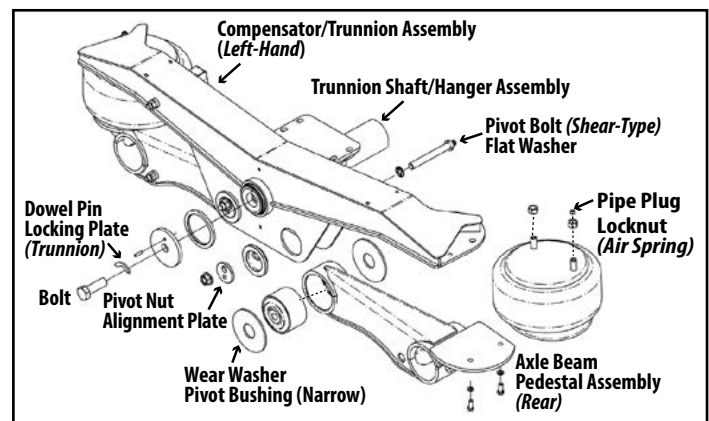
Exhaust all the air from the air system before disassembling the suspension.

**CAUTION** Failure to properly chock wheels and exhaust the air system could allow vehicle movement that could result in serious injury.

## Disassemble Suspension

1. Disconnect and remove the air springs. Remove the shock absorber assemblies.
2. Disconnect and remove the height control valve. Loosen clamp on P-Connector and remove height control valve and linkage.  
NOTE: Do not loosen or remove axle band-clamp.
3. Remove pivot bolts and lower the beam assembly from the compensator/trunnion assembly.  
**CAUTION** Do not reuse shear-type pivot bolts.
4. Grind off weld on locking plate over the trunnion shaft bolt.  
Remove the locking plate, dowel pin, trunnion shaft bolt, end cap and the thrust washer (Fig 16).  
NOTE: Dowel pin required for reassembly.
5. Support compensator/trunnion assembly by wrapping chains around the assembly as close to the trunnion shaft as possible.  
Place a portable hydraulic power unit between the end of the trunnion hanger shaft and the chains wrapped around compensator assembly.  
NOTE: Portable power unit should not press against internal threaded area of trunnion shaft.
6. Remove compensator/trunnion assembly from the trunnion hanger/shaft assembly. Press the center bushing out of the trunnion assembly.
7. Lubricate the opening with silicon spray.  
**CAUTION** Do not use solvent-based lubricants.
8. Place new bushing so that the end number (RW60000-Narrow; 1120048-Wide) faces the center of the trailer. Press bushing into place, making sure it is centered in trunnion opening.
9. Manually dress the outside of the shaft of the trunnion hanger/shaft assembly with emery cloth. Lubricate the outside of the shaft and inside the center bushing with silicon spray.
10. Place thrust washer on trunnion hanger/shaft assembly. Install the trunnion assembly.
11. Install thrust washer, endcap, dowel pin and trunnion shaft bolt onto installed trunnion assembly. Torque shaft bolt to 500 ft-lb.
12. Place locking plate on shaft bolt head to cover the dowel pin and weld in place.

*continued on next page*



**Figure 16.** Remove the front- and rear-axle beam pedestal assemblies before separating compensator assembly from trunnion hanger/shaft assembly.

## Trunnion - Center Bushing Replacement Procedure (Continued)

### Reassemble suspension

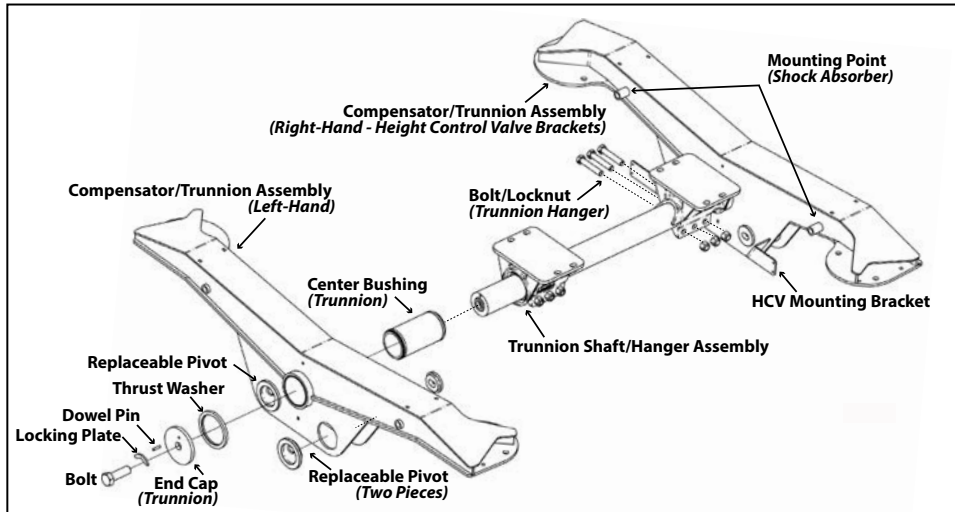
Install axle beam assemblies with one wear washer on each side of pivot bushing. Torque pivot bolt to specifications (Chart-Page 13).

Install and reconnect the height control valve and linkage assemblies.

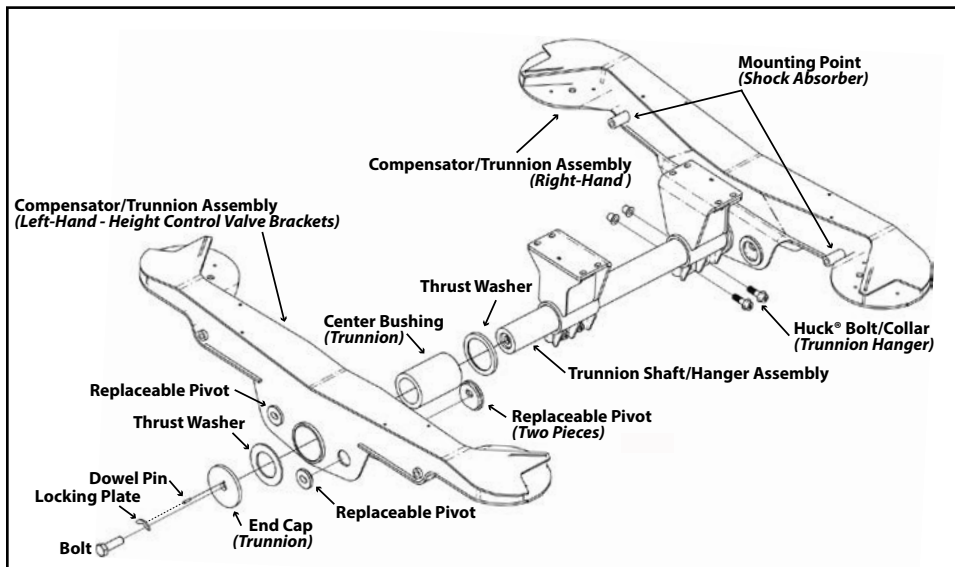
Install air springs. Install shock absorber assemblies.  
NOTE: Check air system after installation for leaks.

Replace wheels and tires. Remove jack stands and lower suspension to ground.

Check installed ride height; adjust if necessary.



**Figure 17.**  
**Narrow Bushing - Compensator/Trunnion Components**  
(see 6110039/610042 drawing)

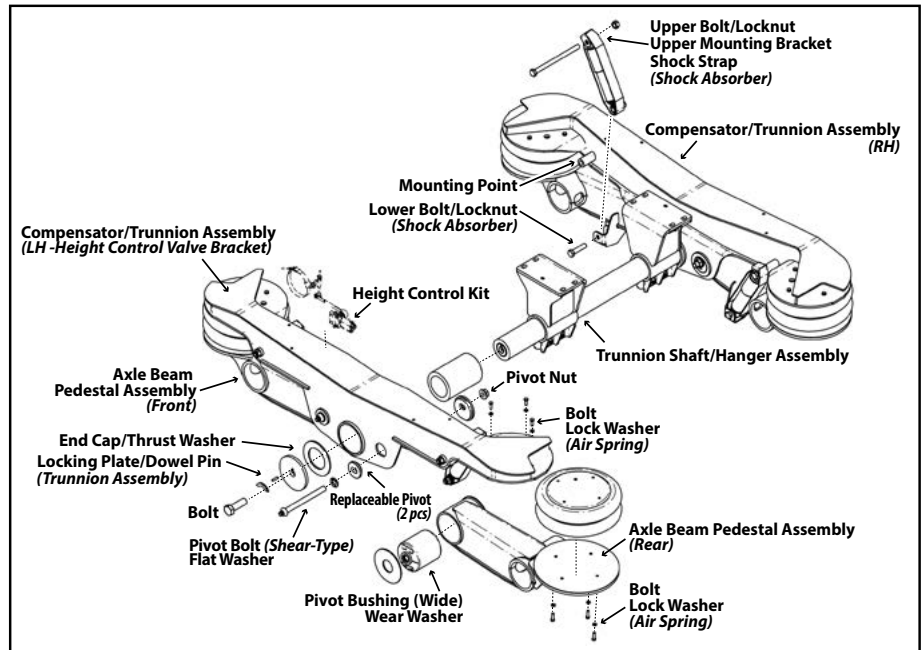


**Figure 18.**  
**Wide Bushing - Compensator/Trunnion Components**  
(see 6110043 drawing)

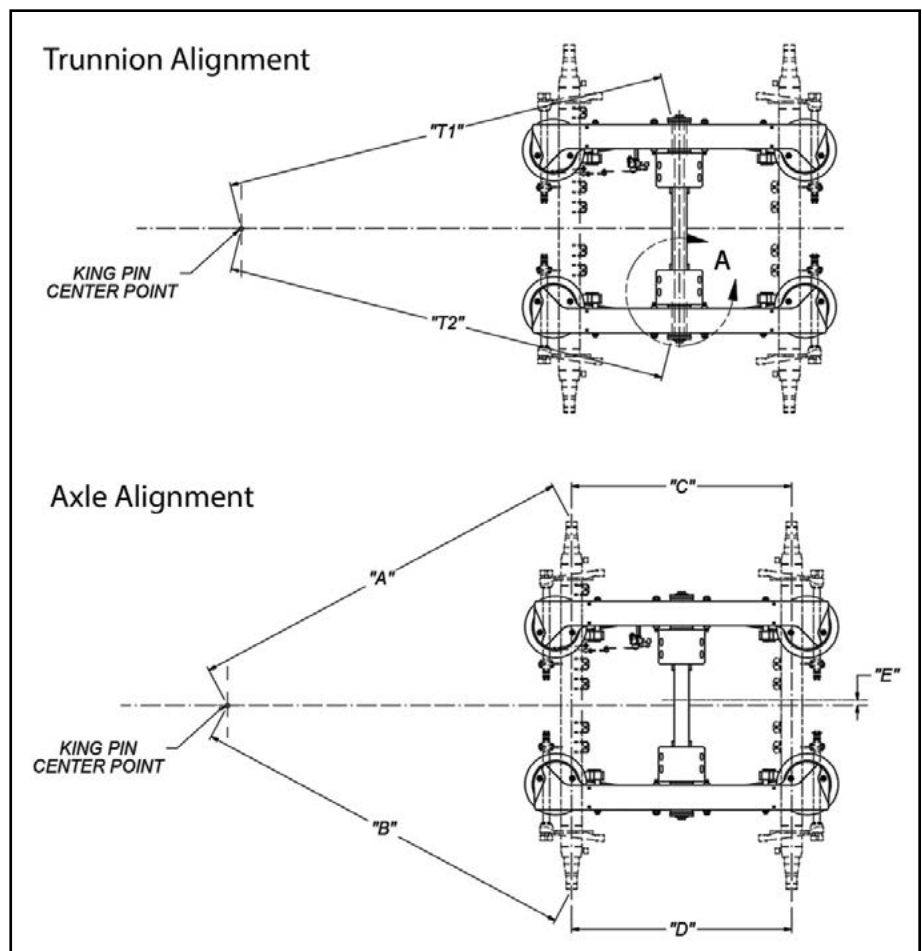
Axle alignment should be performed on a level surface with the suspension installed at the desired ride height.

Front axle alignment should be performed in accordance with SAE or TMC recommended standards.

- Loosen the pivot nut (Figure 19).  
**CAUTION** Do not reuse pivot hardware if Torx® head is damaged or missing. A new shear-type pivot bolt, flat washer and locknut must be installed and the Torx head sheared off to complete the alignment.
- Using 1/2" drive breaker bar, rotate front axle beam alignment plate opposite the direction of desired axle movement.  
 NOTE: It is important that the pivot bushing is not skewed in the hanger prior to tightening.
- Measure from the kingpin center point (Figure 20).  
 Check that dimension "A" and "B" are equal within +/- 1/8". Snug pivot fasteners and recheck axle alignment.
- Repeat alignment process on the rear axle to make sure that "C" and "D" dimensions are equal within +/- 1/16".
- Check the lateral centerline relationship of trailer body and axles (Dimension "E"). Lateral centerline relationship must not exceed 1/4 of an inch.
- Recheck the alignment of the front axle with the kingpin. Check alignment of the rear axle with the front axle.
- Torque all four pivot bolts using a 1" drive impact wrench and #610054 E-20 Torx socket (or equivalent) until the Torx head shears off from the bolt. Welding the alignment plates/washers to the hanger sidewalls is not required or recommended.



**Figure 19.**  
**Trunnion/pivot connections hardware (254-Wide Bushing shown)**



**Figure 20.**  
**Kingpin measurements - trunnion and axle alignment.**

**Terms and coverage in this warranty apply only to the United States and Canada.**

Ridewell Suspensions warrants the suspension systems manufactured by it to be free of defects in material and workmanship. Warranty coverage applies only to suspensions that have been properly installed, maintained and operated within the rated capacity and recommended application of the suspension. The responsibility for warranty coverage is limited to the repair/replacement of suspension parts. The liability for coverage of purchased components is limited to the original warranty coverage extended by the manufacturer of the purchased part.

All work under warranty must have prior written approval from the Ridewell warranty department. Ridewell has the sole discretion and authority to approve or deny a claim and authorize the repair or replacement of suspension parts. All parts must be held until the warranty claim is closed.

Parts that need to be returned for warranty evaluation will be issued a Returned Materials Authorization (RMA). Parts must be returned to Ridewell with the transportation charges prepaid. The transportation charges will be reimbursed if the warranty claim is approved.

This non-transferable warranty is in lieu of all other expressed or implied warranties or representations, including any implied warranties of merchantability or fitness or any obligations on the part of Ridewell. Ridewell will not be liable for any business interruptions, loss of profits, personal injury, any costs of travel delays or for any other special, indirect, incidental or consequential losses, costs or damages.

**Contact the Ridewell Warranty Dept. at 417.833.4565 - Ext. 135, for complete warranty information.**