

RAR-260

Trailer Air-Ride Suspension

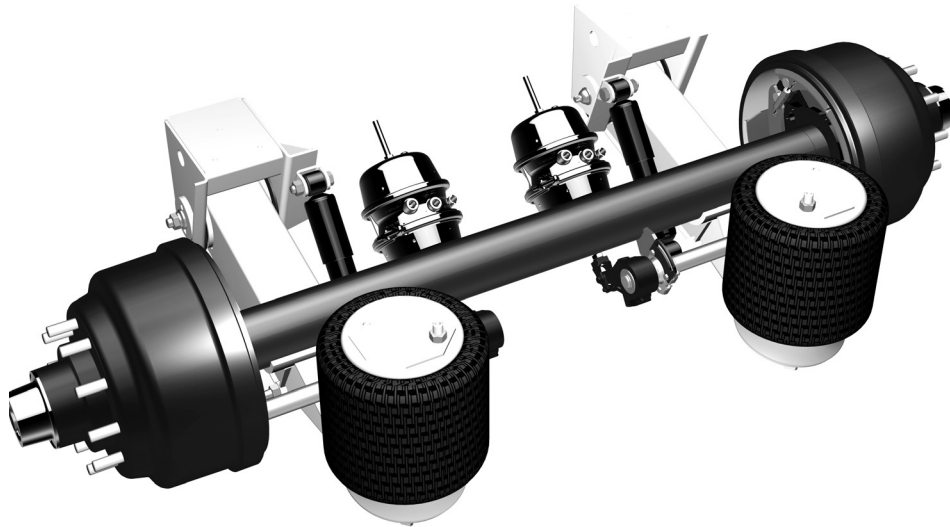

Installation and Service Manual

Suspension Identification 2

Suspension System/Axle Serial Tag

Installation 3

Prior to Installation

Axle Integration

Axle Weld Standards

Suspension Mounting

Troubleshooting - HCV Installation

Maintenance 8

Recommended Service Intervals

Parts Illustrations

25K - Overslung Suspension

30K - Overslung Suspension

15K - Underslung Suspension

25K/30K - Underslung Suspension

25K - Yoke Mount Suspension

(Wide) Bushing Replacement Tool 6100051

Bushing Replacement Kits/Re-Bushing Procedure

Appendix 14

Torque Specifications

Axle Alignment

Warranty 16



Part No.: 9710104

Doc: 260-Trailer-ISM-RevH-09-11-19

SUSPENSION IDENTIFICATION

Introduction

The Ridewell Air Ride (RAR) 260 Trailer Suspension is available in an overslung, underslung or yoke mount configuration. The suspension can be purchased with or without an integrated axle.

Refer to the engineering drawing for detailed information on the suspension system components and operating parameters.

Suspension Identification Tag

A (606-) **Installation/Assembly Number** will be listed as the **Part Number** when other system components are factory installed with the suspension (Figure 1).

The **Suspension Number** and **Serial Number** on the Suspension ID Tag refer to the model and the date of manufacture of an individual suspension system.

Please refer to the suspension number/part number and serial number on the Suspension Identification Tag when contacting Ridewell for customer service, replacement parts and warranty information.

Axle-Body Identification Tag

The **Base-Axle Part Number (165-)** and the **Serial Number** of the axle tube are listed on the Axle-Body ID Tag of Ridewell-branded round axles (Figure 2).

The **Base-Axle Part Number** refers to Ridewell-branded round axles manufactured in various axle wall thicknesses and widths.

More information on Ridewell-branded axles can be found in the "Trailer Axle Parts Guide" (9710029).

Notes and Cautions

All work should be completed by a properly trained technician using the proper/special tools and safe work procedures.

Read through the entire Installation and Service Manual (ISM) before performing any installation or maintenance procedures.

The ISM uses two types of service notes to provide important safety guidelines, prevent equipment damage and make sure that the suspension system operates correctly. The service notes are defined as:

"NOTE": Provides additional instructions or procedures to complete tasks and make sure that the suspension functions properly.

CAUTION Indicates a hazardous situation or unsafe practice that, if not avoided, could result in equipment damage and serious injury.

 RIDEWELL SUSPENSIONS The Engineered Suspension Company	
PART NO:	
SUSP. NO:	
SERIAL NO:	
GROSS AXLE WEIGHT RATING CERTIFICATION IS PER THE FINAL STAGE MANUFACTURER OR ALTERER.	
THIS PRODUCT MAY BE COVERED UNDER ONE OR MORE PATENTS, ADDITIONAL PATENTS MAY BE PENDING.	
www.ridewellcorp.com	(800) 641-4122

Figure 1.
The Suspension Model (Suspension Number) and date of manufacture (Serial Number) are listed on the Suspension Identification Tag.

 RIDEWELL SUSPENSIONS			
MODEL:		PART NO.	
SERIAL NO.		CAPACITY	TON

Figure 2.
The Base-Axle Part Number (165-) and the Serial Number assigned to the axle tube are listed on the Axle-Body Serial Identification Tag.

Prior to Installation

Refer to the engineering drawing to confirm dimensional requirements and the range of ride heights available.

The suspension is designed to fit up onto standard I-beam trailer frames at beam centers that correspond to standard axle track widths (Figure 3).

Installation at wider beam centers will reduce suspension clearances. Installation at narrower beam centers will de-rate the axle beam capacity. NOTE: For non-standard beam centers, frames, frame centers, axle track widths and wheel-end equipment, the installer is responsible for verifying clearances, axle capacity, proper fit-up, and any additional required support structure.

Installations can vary and procedures should be adapted for different vehicles, as needed.

- The Gross Axle Weight Rating (GAWR) is determined by the system component with the lowest load rating. Please consult with tire, wheel, axle and brake manufacturers before installation to determine the GAWR.
- If vehicle chassis modifications are required, consult with the vehicle manufacturer to ensure that such changes are permitted.
- Welding or altering suspension components is not permitted without the express written permission of Ridewell Suspensions.

Installer Responsibilities

The installer of the suspension has the sole responsibility for proper attachment of the suspension system to the vehicle chassis.

- The installer is responsible for locating the suspension system on the vehicle to provide the proper load distribution.
- The installer must verify that vehicle crossmembers are positioned to support the suspension at the installing location.
- It is the installer's responsibility to determine that axle spacing conforms to any applicable federal and local bridge laws.
- The installer must verify that air reservoir volume requirements are met after suspension installation. Consult the vehicle manufacturer or Federal Motor Vehicle Safety Standards (FMVSS) 121 for more information.
- The installer must verify there is sufficient clearance for proper functioning of the suspension, air springs, brake chambers, axle and tires.

Figure 3. Standard Trailer Dimensions

Trailer Width	Axle Track Width	Frame Center	Beam Center	Air Spring Center
96"	71.5"	38"	35"	31"
102"	77.5"	44"	41"	37"

Axle Integration

Suspension systems are available with and without a factory integrated axle. Customer-supplied axle assemblies must be positioned and oriented (rotated) properly before welding the axle to the axle seats.

Use the top-center mark on the axle, if available, to identify the center of the axle and orient the axle assembly on the suspension. The axle assembly should be installed so that the camshafts, when activated, rotate in the same direction as the wheels.

CAUTION Failure to follow procedures and design specifications could result in injury, damage to the axle or suspension and void the warranty.

Weld Preparation

The joint to be welded should be positioned in the flat or horizontal position. All grease, dirt, paint, slag or other contaminants must be removed from the weld joint.

The axle and suspension components should be at a minimum temperature of 60°F (15.5°C). Pre-heat the weld zone to the axle manufacturer's recommended pre-heat temperature, if required.

Weld Procedure

Ridewell recommends supporting the axle and suspension with a weld fixture during axle integration. Contact Ridewell Customer Service for the correct weld fixture for your suspension model.

1. Center the axle assembly on the beam centers (Figure 4).
2. Check the engineering drawing for the brake component orientation (rotation) before clamping into place and making the final welds.
 - 2.1 Drum brake camshafts are spaced off the tail of the trailing arm beam. Make sure the brake chamber brackets are oriented properly and clamp the axle assembly into place.
 - 2.2 Disc brake assemblies have a right- and left-hand caliper assembly. Make sure the callipers are located on the correct side and rotated to the proper position before clamping the axle assembly into place.
3. Check the gap between the axle and the axle seats before welding (Figure 5). Side gaps should be no greater than 1/8". The gap at the bottom of the axle seat should be no greater than 1/16".
4. Weld the axle to the seat according to Ridewell Weld Process #1 (Page 5).

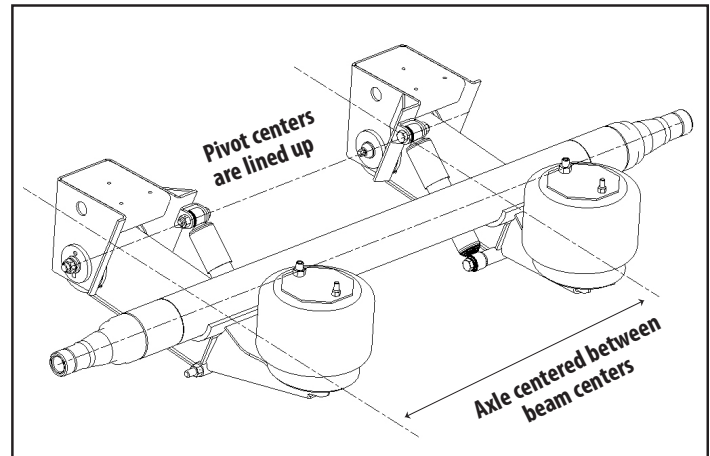

Figure 4. Axle should be centered between beams with beams and axle perpendicular to each other. Refer to the engineering drawing for measurements.

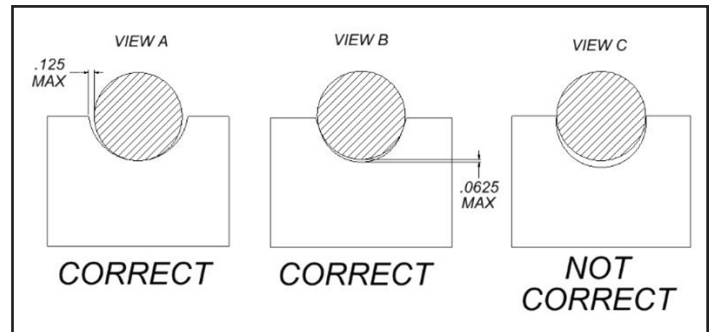
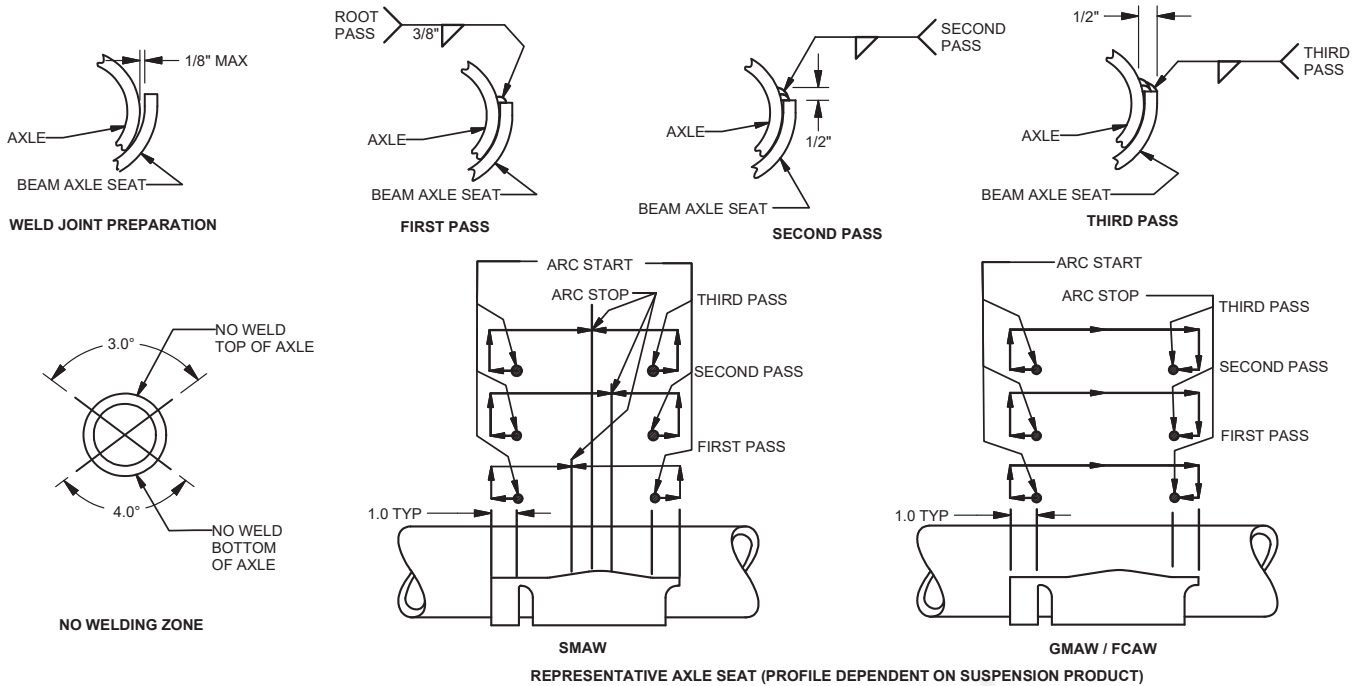
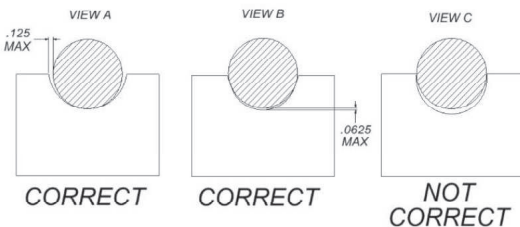

Figure 5. Correct axle tube seating for welding.



- 1 - CAUTION: All welds must be kept away from the top and bottom of the axle where maximum stresses occur (see "NO WELDING ZONE" illustration above). Do not test-weld the arc on any part of the axle tube.
- 2 - All welders and welding operators should be certified as per the requirements of the American Welding Society (AWS) or equivalent. All electrodes used should meet the AWS specifications and classifications for welding carbon and low-alloy steels.
- 3 - Recommended Welding Methods: Shielded Metal Arc Welding (SMAW), Gas Metal Arc Welding (GMAW) or Flux Cored Arc Welding (FCAW). The welding method used and the electrode selected must develop a minimum weld tensile strength of 70,000 psi per AWS specifications. The best fusion and mechanical properties will be obtained by using the voltage, current, and shielding medium recommended by the electrode manufacturer. If the SMAW method is used, the stick electrodes must be new, dry, free of contaminants and stored per AWS specifications.
- 4 - Weld Joint Preparation: The joint to be welded should be positioned in the flat or horizontal position. All grease, dirt, paint, slag or other contaminants must be removed from the weld joint without gouging the axle tube. CAUTION: Never weld when the axle is cold. The axle and beam assemblies to be welded should be at a temperature of at least 60°F (15°C). Pre-heat the weld zone to the axle manufacturer's recommended pre-heat temperature, if required. This will reduce the chance of an area of brittle material forming adjacent to the weld.
- 5 - The axle should fit into the beam assembly with a maximum root gap of 1/8-inch between the axle and the beam axle seat (see "WELD JOINT PREPARATION" illustration above).
- 6 - NOTE: Clamp the axle to the beam axle seat with a C-clamp prior to welding to make sure that proper contact occurs (see "CORRECT" illustration below).
- 7 - Ground the axle to one of the attached axle parts such as the brake chamber brackets, cam brackets or brake spider. Never ground the axle to a wheel or a hub as the spindle bearing may sustain damage.
- 8 - Multiple pass welding should be used on the beam/axle connection using the following guidelines: 8.1-Total fillet weld size should be 1/2-inch. 8.2-Weld pass starts and stops should be performed as illustrated above. 8.3-Never start or stop welds at the end of the weld joint. 8.4-Each pass must be accomplished in one or two segments. 8.5-Start welds at least 1-inch from the end and backweld over the start. Backstep fill all craters. 8.6-If process is not GMAW all slag must be removed between passes. 8.7-Welds must go to within 1/8-inch +/- 1/16-inch of the ends of the axle seat and must not go beyond or around the ends of the axle seat. 8.8-Post-weld peening is recommended, but not required: Needle peen the entire toe of the second pass, including around the ends of the axle seat. Hold the needles perpendicular to the axle. A uniform dimpled pattern will appear when properly peened.



F	16101	ADDED MAXIMUM TO 5, ADDED GMAW NOTE TO 8.6 UPDATED CORRECT VIEWS	2/10/2016	G.H.	B.B.	CJB
E	15101	REVISED TEXT. REMOVED LIST OF MODELS.	6/30/15	G.H.	MDJ	CJB
REV	PROJECT	DESCRIPTION	DATE	BY	CHK	APPD
DRAWN BY:	CBC	2/1/2016	RIDEWELL CORPORATION PO BOX 4586 SPRINGFIELD, MISSOURI 65808			
CHECKED:	MDJ	2/21/2003				
APPROVED:	CJB	2/21/2003				
PROJECT NO:	03103	SCALE: A-SIZE: NTS	TITLE: RIDEWELL WELD PROCESS #1, 5" DIA. AXLE, 3 PASS WELD			
MATERIAL:	-	WEIGHT:	-	SHEET 1 OF 1		PART NO: WELD PROCESS #1
						REV: F

Mounting the suspension to the frame

Refer to the engineering drawing for the range of ride heights available, torque values, spacing and clearance requirements of the suspension.

Recommended locations of customer-furnished filler plates and supporting crossmembers for the suspension hangers and air spring mounting plates are shown on the engineering drawing.

The suspension installer has the final responsibility of attaching the suspension to the vehicle frame.

Weld-On Installation Procedure

⚠CAUTION Welding method must use a minimum weld tensile strength of 70,000 psi, per AWS specifications.

1. Mark the desired location of the hangers and filler plates on the vehicle frame. Hangers must be installed parallel to each other for proper axle alignment.
2. Mark the desired location of the air spring mounting plates and filler plates on the frame.
3. Install filler plates for the hangers and air spring mounting plates on the frame. Weld filler plates to crossmembers with 1/4" fillet welds down the length of the crossmember.
4. Weld the hangers to the frame/filler plates with 1/4" fillet welds completely around the hangers. Stop the welds 1/2" from the corners and edges.
 - 4.1 For hangers with wing gussets, the wing gussets must be welded to a crossmember or other supporting structure.
 - 4.2 A length of 1 1/2"-diameter pipe can be placed through the holes in the two hangers to help with stabilization and alignment.
5. Weld the air spring mounting plates to the frame/filler plates with 3/16" fillet welds.
6. Attach a crossmember or diagonal brace to the front of the hangers with 1/4" fillet welds.

Bolt-On Installation

Before installation, check to make sure that wires, hoses or other components will not be affected by drilling into the frame rail.

- Bolts/nuts for attaching the suspension to the vehicle are supplied by the installer. Grade 8 bolts and flanged lock nuts or lock nuts with hardened washers are recommended.
- Bolt holes are not provided in the air spring mounting plates. Clamp mounting plates and filler plates (if necessary) in place before drilling.

Final Assembly and Inspection

- Verify the welds of the hanger and air spring mounting plates.
- Check the location for sufficient clearances of suspension components.
- Attach beam and axle assemblies to hangers. Note: Do not fully torque pivot hardware until axle alignment is completed.
- Complete assembly and installation of air springs as shown on the engineering drawing. Torque to specifications (Appendix).
- Install shock absorbers. NOTE: If the suspension is painted after shocks are installed, make sure paint overspray does not get under the shock absorber dust covers.
- Install/connect the height control valve (HCV), if applicable (Page 7). Check the air system tubing and fittings after installation for leaks.
- Verify the suspension ride height is adjusted within the range shown on the engineering drawing and complete axle alignment procedure (Appendix).

⚠CAUTION Failure to torque bolts/nuts of suspension components to specifications can result in failure of the suspension and void the warranty.

Install the height control valve

The Ridewell Extreme Air® Height Control Kit (HCK) automatically adds and exhausts air from the air suspension to maintain the vehicle ride height as loads increase and decrease. The (HCK) assembly consists of a lever arm connected to the height control valve (HCV) and a vertical rod arm (vertical linkage) connected to the suspension/axle (Figure 6).

Refer to the Extreme Air® installation guide for installation procedures. Be sure to check the air system after installation for leakage. **CAUTION** The installer is responsible for making sure that air system requirements comply with the appropriate Federal Motor Vehicle Safety Standards.

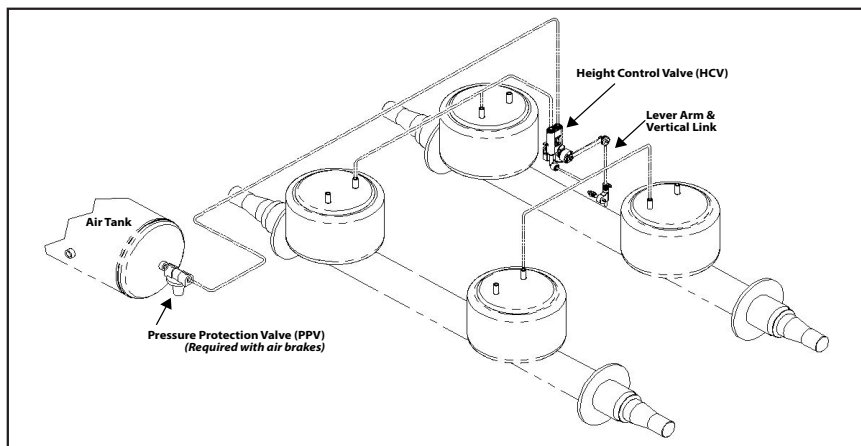
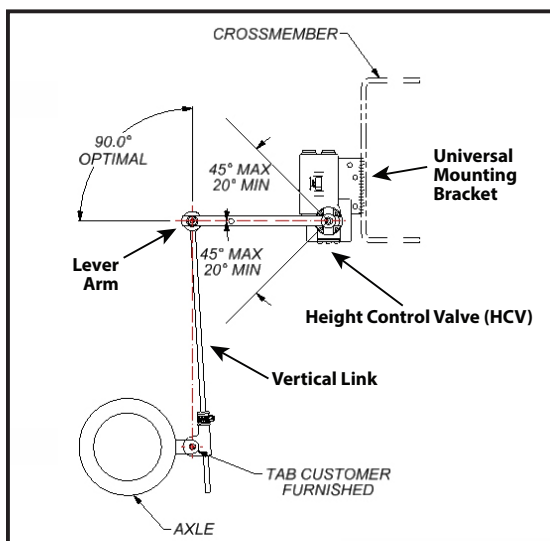

Figure 6. Example of single Height Control Valve (HCV) installation on vehicle frame with linkage attached to the axle.

Troubleshooting – Height Control Valve Installation

Problem	Possible Cause	Corrective Action
HCV is not receiving air/ HCV is not delivering air to the air springs.	<ul style="list-style-type: none"> Blocked air supply line. Air tank is not filling/reaching set pressure. Pressure Protection Valve (PPV) not working correctly. Pilot port is not plumbed or is plumbed incorrectly. 	<ul style="list-style-type: none"> Verify air lines are pressurized by removing supply line at HCV. Check for pinched lines. Verify air tank pressure with manual/in-line pressure gauge. Check PPV operation by making sure that valve opens when system reaches the desired pressure setpoint (<i>usually greater than 70 psi</i>). Check HCV configuration – Non-Dump; Pressure-Dump (Normally Open); Zero-Pressure Dump (Normally Closed). Reinstall, if necessary.
Air springs fill but do not exhaust.	<ul style="list-style-type: none"> Obstructed air line. HCV installed backwards. Supply line installed in suspension port 	<ul style="list-style-type: none"> Disconnect linkage and rotate actuating lever to down position (exhaust). If springs remain inflated, check for pinched/blocked lines. Check installation. Reinstall, if necessary. Move air supply line to HCV supply port.
Air system leaks down in a short period of time.	<ul style="list-style-type: none"> HCV installed backwards. Leak in air system beyond accepted standards. 	<ul style="list-style-type: none"> Disconnect HCV linkage and rotate actuating lever to the up position (fill). If air springs do not inflate, reinstall HCV. To find leak in the HCV area, pressurize system and spray soapy water solution onto the valve and lines. Check for bubbles (leaks): No leak found – Do not remove valve, check the rest of the system for leaks. Check that tubing cuts are straight and smooth. Re-cut and reassemble if necessary.

MAINTENANCE

A visual inspection of the suspension structure should be performed during each pre-trip/safety inspection. Ridewell Suspensions recommends the following minimum service intervals for standard duty, on-highway usage applications. More frequent intervals are recommended for heavier duty applications.

Daily/Pre-Trip Inspections

- ___ Check tires for proper inflation, damage or excessive wear.
- ___ Check wheel-ends for obvious signs of lubricant leakage. Check for missing components.
- ___ Check axle assemblies for damage or loose components.
- ___ Visually inspect suspension structure for signs of damage or excessive wear.
- ___ Check for loose or missing bolts/nuts. Check for irregular movement in suspension components.
- ___ Make sure air controls are operating properly. Drain all moisture from air reservoirs.

First 6,000 miles of use

- ___ Torque all suspension component bolts/nuts to specifications (Appendix/Engineering drawing).
- ___ Verify that the suspension is operating at the installed ride height.

Refer to the following Technology & Maintenance Council (TMC) publications for additional maintenance information:

TMC RP 609	Self-Adjusting and Manual Brake Adjuster Removal, Installation and Maintenance
TMC RP 618	Wheel Bearing Adjustment Procedure
TMC RP 619	Air System Inspection Procedure
TMC RP 622	Wheel Seal and Bearing Removal, Installation, and Maintenance
TMC RP 631	Recommendations for Wheel End Lubrication
TMC RP 643	Air Ride Suspension Maintenance Guidelines
TMC RP 728	Trailer Axle Maintenance

Every 12,000 miles of use

- ___ Inspect air springs for any damage or excessive wear. Torque air spring bolts/nuts to specifications (Appendix/Engineering drawing).
- ___ Check air lines and connections for leaks.

Every 50,000 miles of use

- ___ Torque all suspension component bolts/nuts to specifications (Appendix/Engineering drawing).

Annually/100,000 miles of use

- ___ Inspect pivot connection for worn pivot bushing and wear washers. Replace components, if necessary. Torque suspension component bolts/nuts to specifications (Appendix/Engineering drawing).
- ___ Check arm beam-to-axle connection welds.
- ___ Check lubrication level in wheel ends:
 - 1) Oil-Filled Wheel Ends:
Refill/Replace lubricant as needed (Refer to TMC RP 631 "100K/Annual Inspection").
 - 2) Semi-Fluid Grease:
Pull outer bearing and visually inspect lubrication level. Refill/Replace as needed (Refer to TMC RP 631 "Level 3 Lubrication Level Inspection" and TMC RP 618 "Wheel Bearing Adjustment Procedure").
- ___ Check air lines and connections for leaks.
- ___ Test air control system pressure protection valve (PPV), if equipped.
- ___ Check height control valve (HCV) adjustment.
- ___ Verify that the suspension is operating at the installed ride height.

CAUTION Failure to torque the bolts/nuts of suspension components to specifications can result in failure of the suspension and voiding of the warranty.

Pivot Bushing Inspection Procedure

Park the unloaded trailer on a level surface. Set the brakes and chock the tires so vehicle cannot move during inspection.

Insert the flat end of a pry-bar between one side of the hanger sidewall and the wear washers. Move the pry-bar back-and-forth and look for excessive movement of the beam (NOTE: A small amount of beam

movement because of the rubber flexing is normal). Inspect the wear washers for excessive wear/damage.

Repeat the pry-bar process and wear washer inspection on the other side of the hanger. If any large/easy movement or damaged wear washers is observed, drop the beams for further inspection. Replace components as necessary.

Figure 7.
RAR-260 - 25K
Trailer - Overslung

Refer to the engineering drawing for the individual component part number.

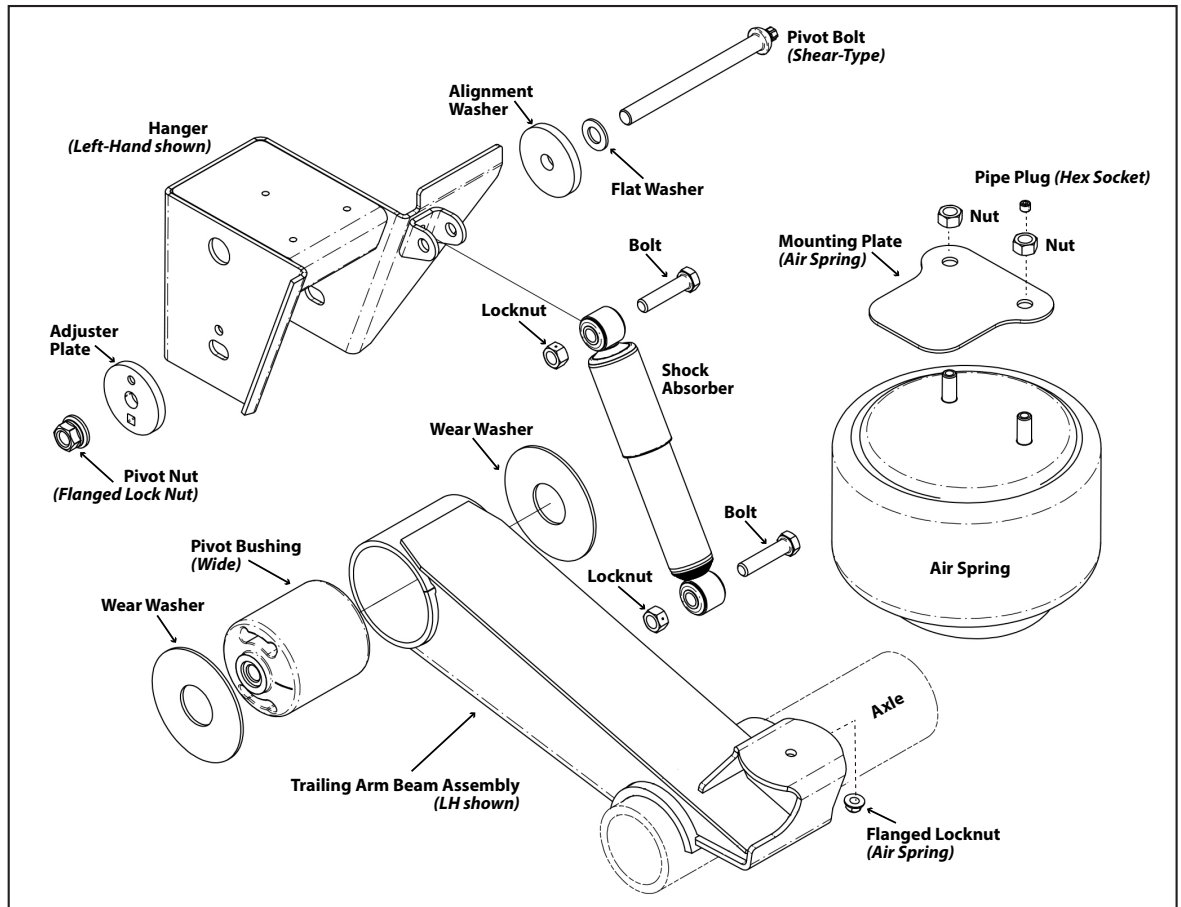
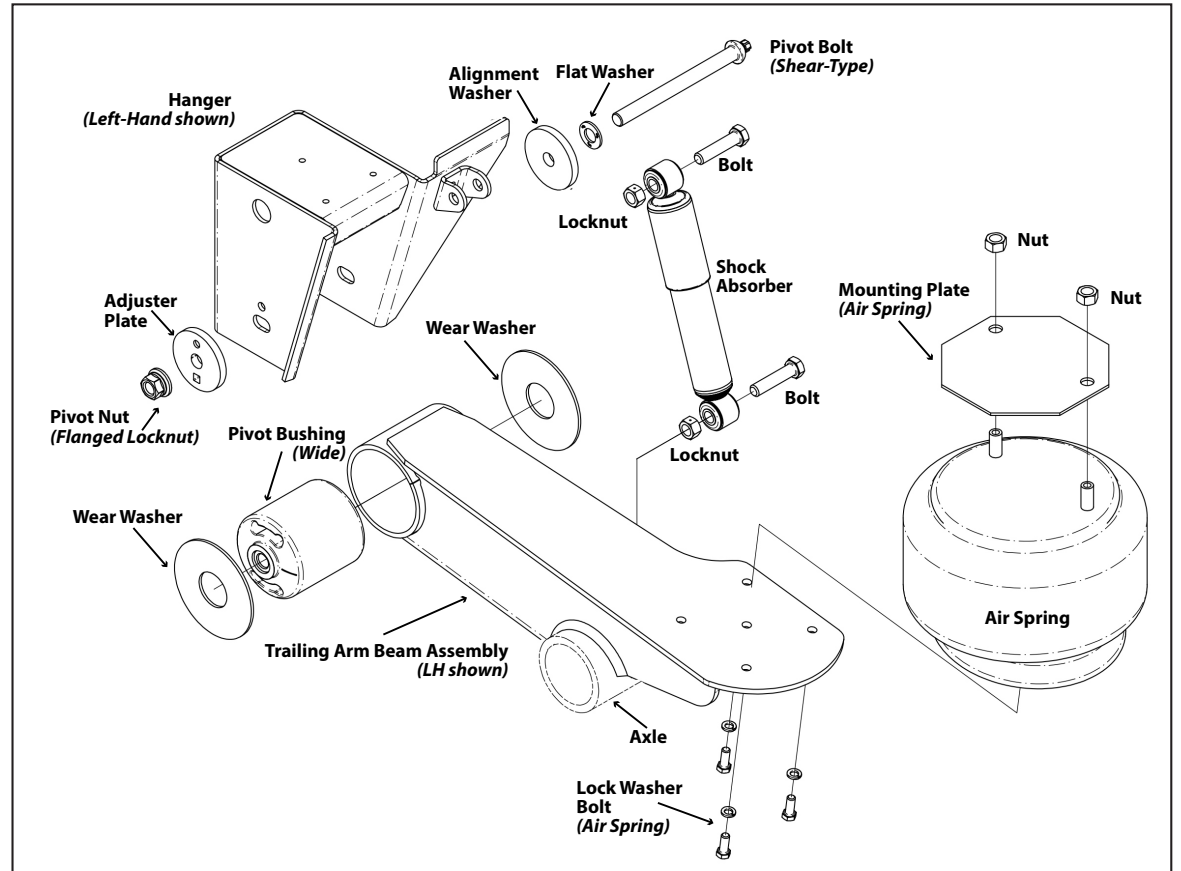

Figure 8.
RAR-260 - 30K
Trailer - Overslung

Refer to the engineering drawing for the individual component part number.



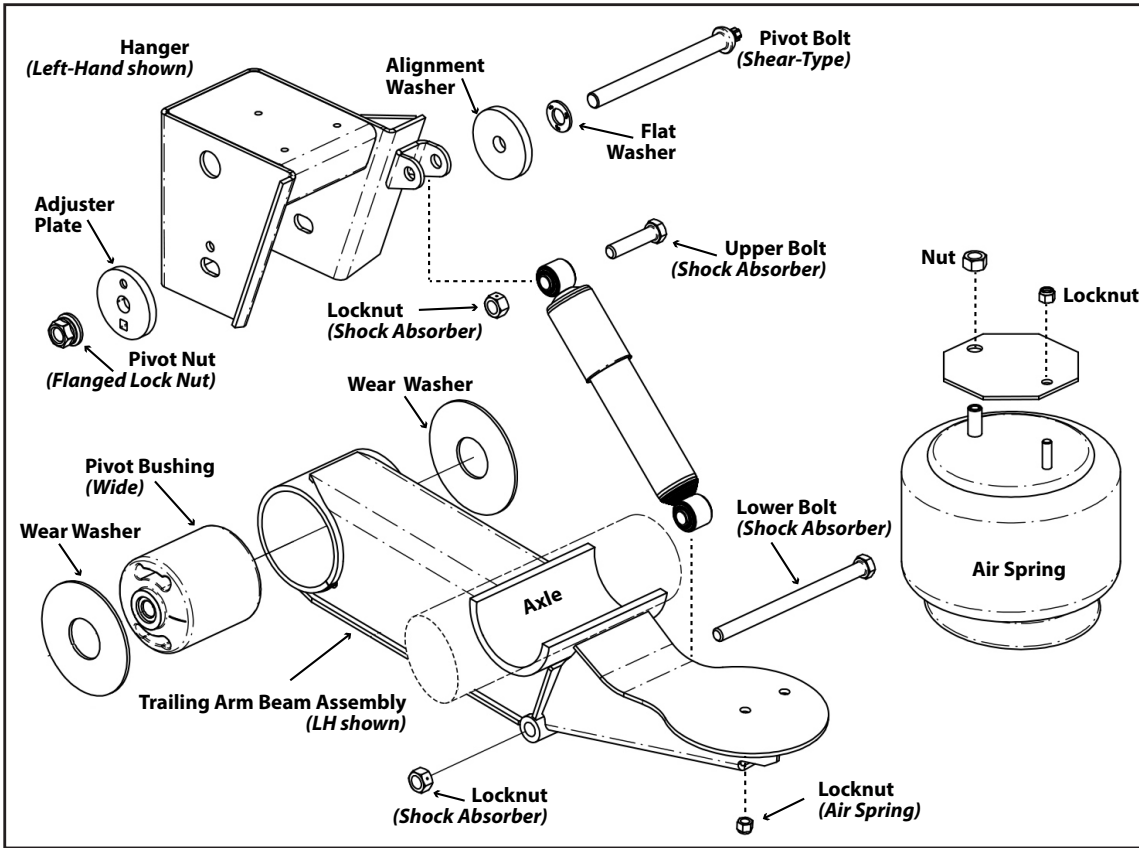

Figure 9.
RAR-260 - 15K
Trailer - Underslung

Refer to the engineering drawing for the individual component part number.

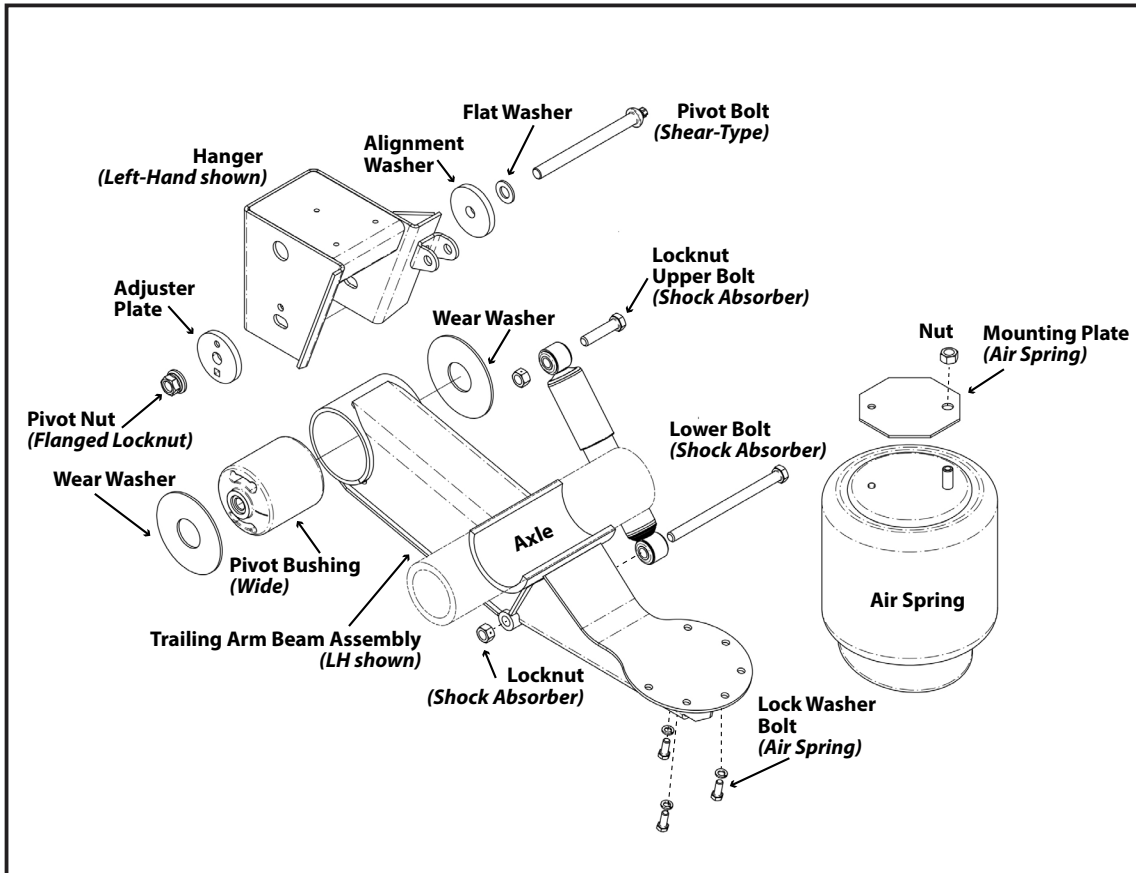

Figure 10.
RAR-260 - 25K/30K
Trailer - Underslung

Refer to the engineering drawing for the individual component part number.

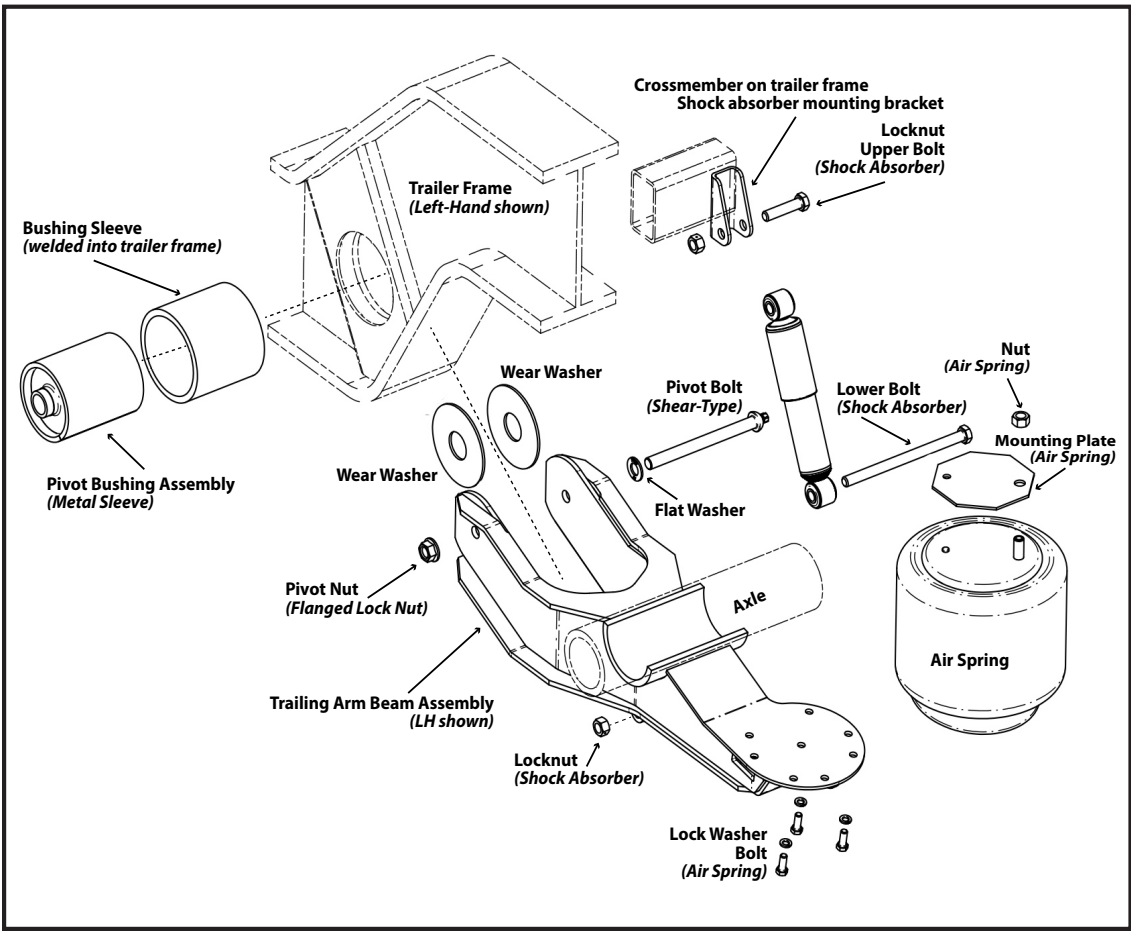

Figure 11.
RAR-260 - 25K Trailer
Yoke Mount
 Refer to engineering drawing for the individual component part number.

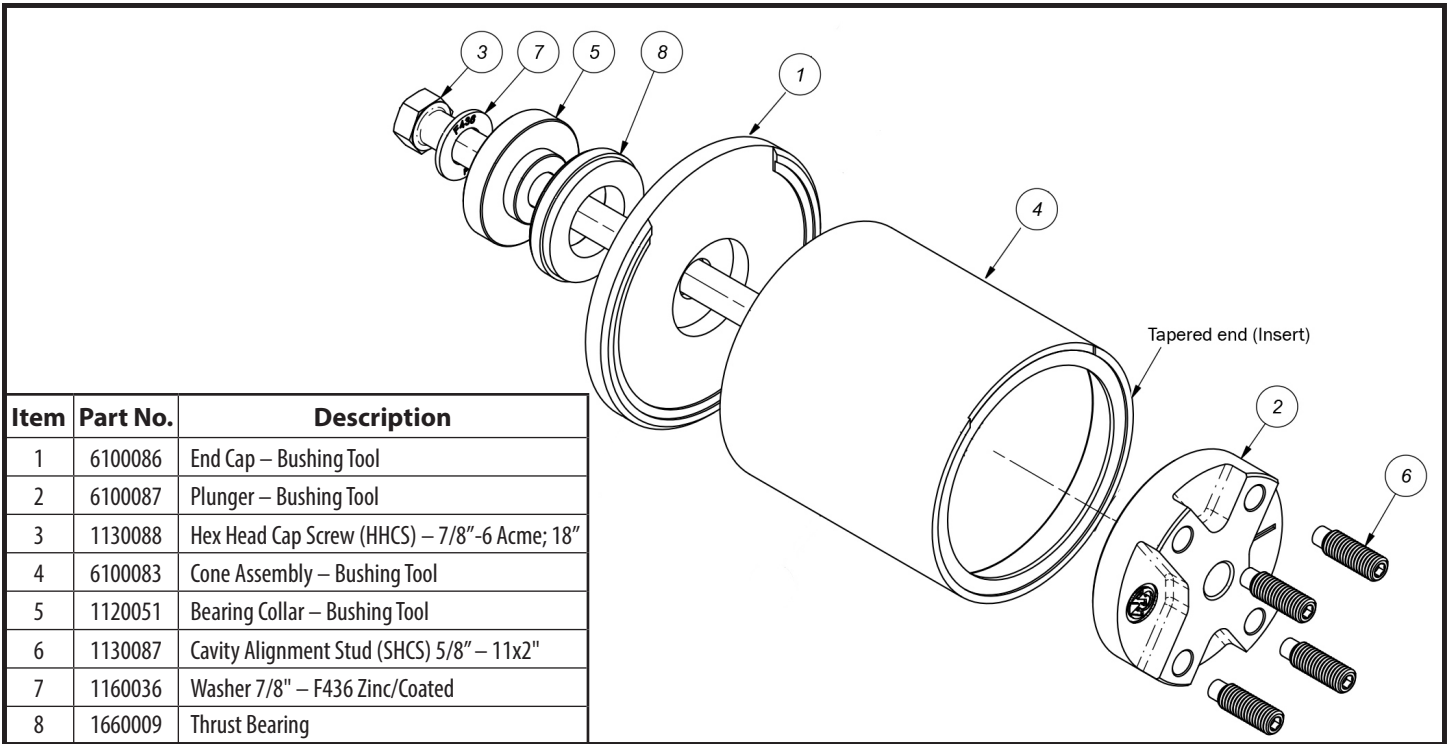

Figure 12. Bushing Replacement Tool #6100051.
 The bushing tool is used to remove/install wide (6 3/4") bushings in RAR-260 Hanger Mount Suspensions.

RAR-260 Trailer Suspension – Bushing Replacement Kit

Suspension Type	REPL Kit P/N	REPL Tool P/N	Pivot Bolt	Torque Specification
Overslung/Underslung	6040098	6100051	Shear-Type	Do not lubricate bolt/nut threads. Use a 1" drive impact wrench to tighten pivot bolt until the Torx® head is sheared off.
Yoke Mount	6040099	—	Shear-Type	

CAUTION Failure to install and maintain pivot hardware at torque specification could result in suspension failure and void the warranty. Refer to the engineering drawing for torque values.

Overslung/Underslung Suspension Re-Bushing Procedure – Bushing Tool 6100051

Park vehicle on a level surface. Chock wheels to keep vehicle from moving. Raise vehicle to height that removes load from suspension and support with jack stands. Disconnect height control valve(s) linkage, if necessary, and exhaust all air from system. **CAUTION** Failure to properly chock wheels, exhaust air system, raise, and safely support the vehicle could allow vehicle/suspension movement that could result in serious injury.

Tool Assembly

Make sure that thrust washer is seated firmly in the flat (outside) edge of the end cap. Examine the tool cone tapered insert and large end for damage/out-of-round. Repair or replace, if necessary.

Bushing Removal

1. Draw/scribe a line on the trailing arm beam using the locator mark on the installed bushing as reference (Fig 14).
2. Lubricate the hex-head bolt threads and the thrust washer bearings with Extreme Pressure Lube (P/N 1980014). NOTE: Failure to apply lubricant could result in decreased performance and reduced tool life.
3. Place the flat washer onto the hex-head bolt, followed by the bearing collar, then the end cap assembly.
4. The bushing tool cone is tapered inside

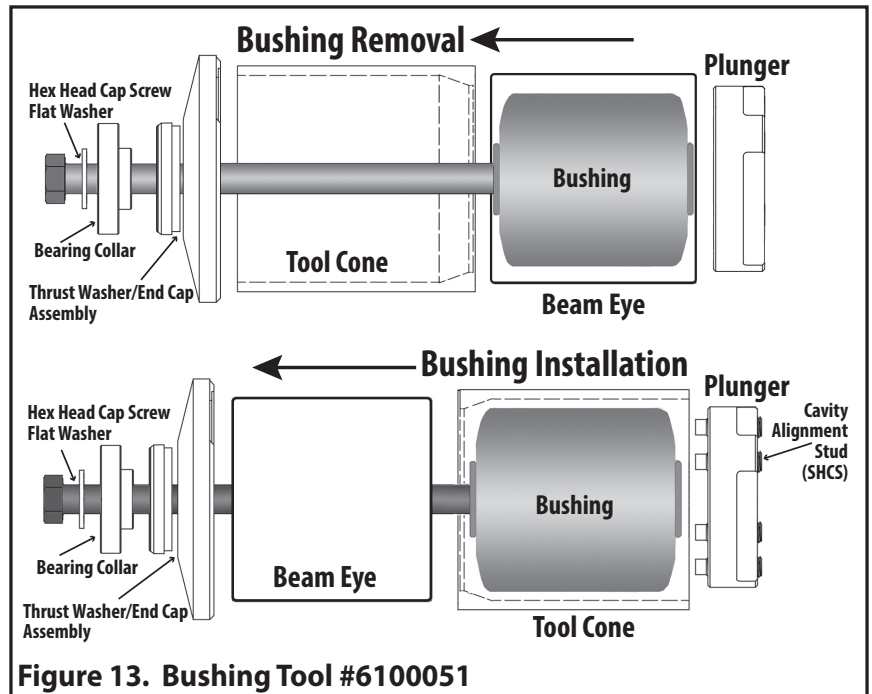
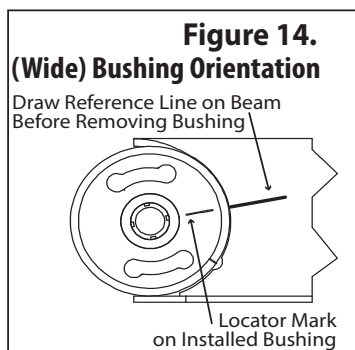

Figure 13. Bushing Tool #6100051



5. Insert the end of the hex bolt through bushing sleeve into the center opening of plunger. Make sure the cone is centered on the beam eye and tighten the hex bolt until the plunger is held firmly against the bushing.
6. Use a 1 1/4" socket on a 3/4" drive impact wrench (1" recommended) to rotate the hex bolt and press the bushing out of the beam eye into the cone. NOTE: In some cases, a small amount of

heat may be required to break the bond between the bushing and the beam eye. Do not overheat. Allow beam to cool before installing bushing.

7. Disassemble the bushing tool. Remove the old bushing from the bushing tool cone and discard.

Tool Assembly-Installation

Place the flat washer, the bearing collar, and the end-cap assembly on the hex-head bolt. Insert the smooth end of each Cavity Alignment Stud (Socket Head Cap Screw- SHCS) into the four holes on the outside edge of the bushing tool plunger.

Tighten alignment stud (SHCS) until the socket head(s) is flush with the edge of the plunger. Smooth end(s) of the stud should extend beyond the inside edge of plunger (Figure 13).

Bushing Installation

1. Use wire brush to clean debris and corrosion out of the beam eye.

Bushing Installation (continued)

- Coat inside of beam eye, outside of the bushing and inside of tool cone with S.G. Type "M" Rubber Assembly Oil. NOTE: Do not substitute; Type "M" Oil included with the bushing replacement kit.
- Insert new bushing into the large end of the tool cone. Make sure locator mark on bushing is visible.
- Line up locator mark on plunger with the locator mark on the bushing. Insert the four cavity alignment studs into the bushing cavity holes and press the plunger firmly against the end of the bushing. NOTE: SHCS threads should NOT touch the bushing (Figure 13).
- Align plunger locator mark with the line drawn/ scribed on the beam. Place the plunger/cone/bushing assembly on the beam eye.
- Insert the hex-head bolt assembly through the beam eye. Thread the hex bolt into the plunger until the end-cap rests against the beam.
- Center the bushing tool cone on the beam eye. Attach a 1 1/4" socket to a 3/4" drive impact wrench (1" impact wrench recommended) to rotate the hex bolt and press the bushing into the beam eye.

- Disassemble and remove the bushing replacement tool. Check placement to make sure bushing is centered in the beam.
- Check the bushing locator mark against line drawn on the beam to make sure bushing is properly oriented.

Reassemble suspension

Rotate trailing arm beams into hangers. Install pivot connection hardware – alignment washers, adjuster plates, wear washers, shear-type pivot bolt, flat washer and flanged lock nut. NOTE: Do not lubricate pivot bolt/nut. Tighten flanged lock nut until adjuster plate pin is engaged and pivot hardware is snug against hanger. Do not apply final torque until axle alignment has been checked.

Install shock absorbers. Connect height control valve linkage (if disconnected) and inflate air springs. Install wheels and tires (if removed).

Raise vehicle and remove support stands. Lower vehicle. Check axle alignment. Realign, if necessary. Tighten pivot bolt with a 1" drive impact wrench and E-20 Torx® socket (Ridewell tool #6100054) until Torx® head is sheared off.

CAUTION Failure to torque hardware to specifications can result in failure of the suspension and void the warranty.

Yoke Mount Suspension Re-Bushing Procedure

Chock wheels. Raise vehicle to height that removes load from suspension and support with jack stands. Disconnect height control valve(s) linkage, if necessary, and exhaust all air from the air springs.

CAUTION Failure to properly chock wheels, exhaust air system, raise and safely support vehicle could allow movement that could result in serious injury.

Disassemble Suspension

Remove wheels and tires, if necessary. Remove shock absorbers. Remove pivot hardware and discard (new hardware included in bushing replacement kit).

Rotate trailing arm beams down and away from frame. Inspect the pivot bolt holes and wear washers for unusual wear or damage. Repair or replace components, as needed.

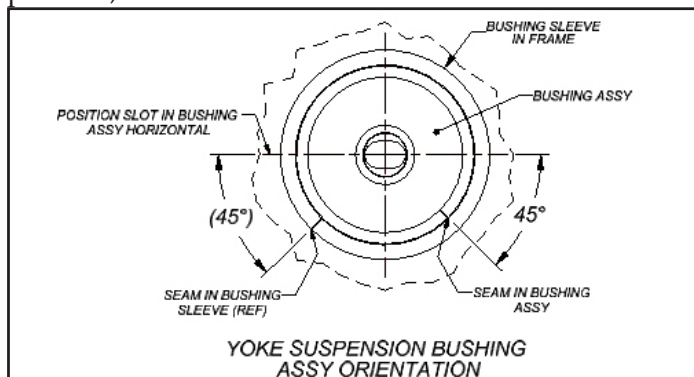

Figure 15. RAR-260 Yoke Mount

Bushing Removal and Installation

- Remove bushing assembly from the bushing sleeve welded to the frame by grinding away the four (4) welds on each side of the bushing sleeve/frame bushing sleeve assembly.
- Position (center) new bushing in the bushing sleeve welded to frame. Align the bushing assembly center slot and seam (Figure 15).
- Attach bushing to the frame bushing sleeve with four (4) one-inch welds on each side. NOTE: Excessive heat and distortion can damage the bond between the rubber bushing and steel sleeve of the bushing assembly. Welds should be staggered and the steel allowed to cool between welds.

Weld the top of the bushing sleeve at the outboard side of frame, then the bottom of the sleeve at the inboard side of frame and move the welds around the sleeve in 90° increments.

Reassemble suspension

Rotate beams up onto frame. NOTE: Do not lubricate pivot bolt/nut. Install new pivot hardware and wear washers. Do not apply final torque.

Install shock absorbers. Install wheels and tires (if removed). Raise vehicle and remove support stands. Lower vehicle to ground. Connect HCV linkage (if disconnected) and adjust ride height. Check alignment and realign (Appendix).

Tighten pivot bolt with a 1" drive impact wrench and E-20 Torx® socket (Ridewell tool #6100054) until the Torx® head is sheared off.

APPENDIX

RAR-260 Trailer Suspension - Torque Specifications

Fastener Type	Size	Torque Values	
		foot-pound	Newton-meter
Pivot Bolt - (Shear-Type) Pivot Nut - (Locknut) <i>Requires E-20 Torx® socket (RW #6100054)</i>	7/8" - 9NC	Do not lubricate bolt/nut threads. Use a 1" drive impact wrench to tighten the pivot bolt until the Torx® head is sheared off.	
Locknut - (Shock Absorber)	3/4"-10NC	200-230 ft-lb	271-312 N-m
Nut - (Air Spring)	3/4"-16NF	45-50 ft-lb	61-68 N-m
Locknut - (Air Spring)	1/2"-13NC	20-25 ft-lb	27-34 N-m
Locknut - (Air Spring - 25K O/S)	1/2"-13NC	45-50 ft-lb	61-68 N-m
Bolt - (Air Spring)	1/2"-13NC	20-25 ft-lb	27-34 N-m
<p><i>Refer to the engineering drawing for component torque value. Torque values reflect a lubricated thread condition (Nuts are pre-lubed). Do not overtorque.</i></p> <p>⚠ CAUTION <i>Suspension is shipped with minimal torque applied to fasteners. It is the installer's responsibility to apply the proper torque values. All fasteners, except for shear-type pivot bolt, must be re-torqued after the first 6,000 miles of operation. Failure to install and maintain suspension component fasteners at torque specifications could result in suspension failure and void the warranty.</i></p>			

Axle Alignment

Alignment should be performed on a level surface with the suspension at the desired ride height.

Align the suspension per TMC or SAE recommended standards. On a multiple-axle vehicle, the forward axle is moved into the proper alignment, then the remaining axles are positioned so that they are parallel to the forward axle. A maximum tolerance of 1/8-inch difference from side-to-side of the forward axle and 1/16-inch difference from side-to-side for the aft axles is acceptable (Figure 14).

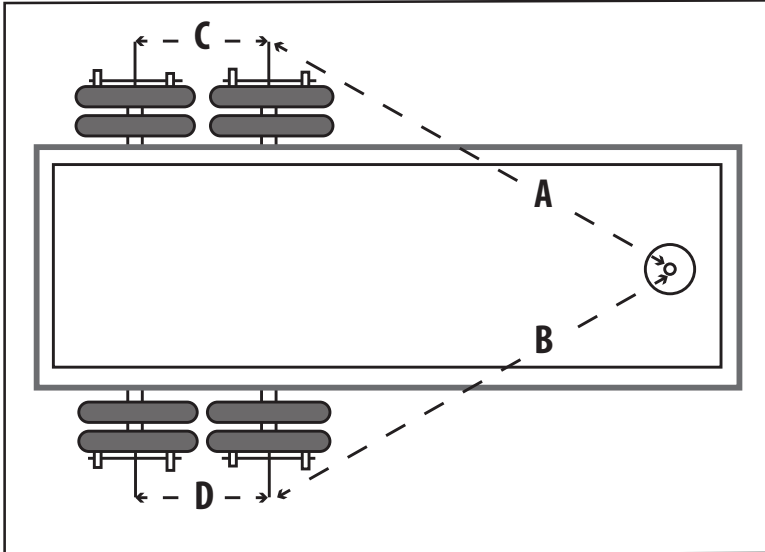

Figure 16.
Kingpin measurement for axle alignment.

Check the forward axle alignment by measuring from the kingpin to both ends of the axle centers. If the difference between the “A” measurement and the “B” measurement is greater than 1/8-inch, the forward axle needs to be aligned. If the difference between the “C” measurement and the “D” measurement is greater than 1/16-inch, the aft axle needs adjustment.

Speed Set® Alignment

The RAR-260 Trailer Suspension is equipped with the Ridewell Speed Set® alignment feature for simple, manual alignment of the axle.

Axle alignment procedure

1. Loosen the pivot nut enough for beam to move.
2. Locate the adjuster plate at the pivot connection. Insert a 1/2”-shank breaker bar into the square hole of the adjuster plate. Move the arm beam forward or backward until the axle reaches alignment (Figure 15). NOTE: Check to make sure that the pivot bushing is not wedged sideways during

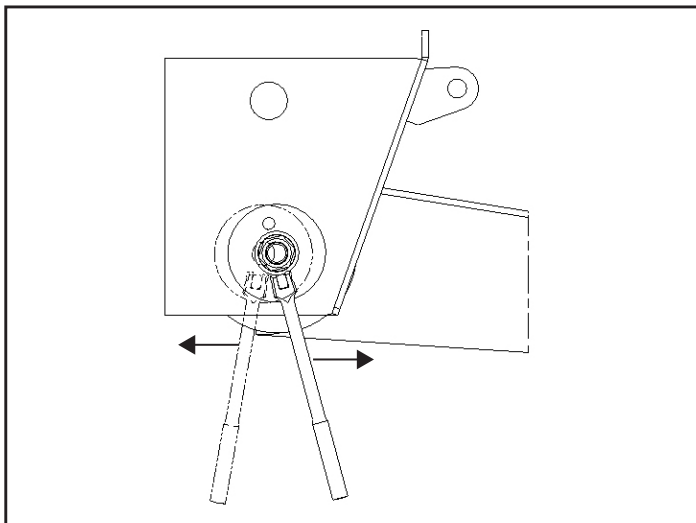

beam movement. The adjuster plate and alignment washer on the two sides of the hanger should move in unison with the beam.

3. Tighten the pivot nut so that beam can no longer move. Re-check alignment measurements and adjust, if necessary. NOTE: Check to make sure that both the adjuster plate and alignment washer are flat against the hanger before final torque is applied.
4. Use a 1” drive impact wrench with an E-20 Torx® socket to tighten the pivot bolt until the Torx head is sheared off.

CAUTION Failure to properly torque pivot hardware could result in catastrophic suspension failure and void the warranty

Figure 17.
Move beam back-and-forth using adjuster plate until axle reaches desired position.

WARRANTY

Terms and coverage in this warranty apply only to the United States and Canada.

Ridewell Suspensions warrants the suspension systems manufactured by it to be free of defects in material and workmanship. Warranty coverage applies only to suspensions that have been properly installed, maintained and operated within the rated capacity and recommended application of the suspension. The responsibility for warranty coverage is limited to the repair/replacement of suspension parts. The liability for coverage of purchased components is limited to the original warranty coverage extended by the manufacturer of the purchased part.

All work under warranty must have prior written approval from the Ridewell warranty department. Ridewell has the sole discretion and authority to approve or deny a claim and authorize the repair or replacement of suspension parts. All parts must be held until the warranty claim is closed.

Parts that need to be returned for warranty evaluation will be issued a Returned Materials Authorization (RMA). Parts must be returned to Ridewell with the transportation charges prepaid. The transportation charges will be reimbursed if the warranty claim is approved.

This non-transferable warranty is in lieu of all other expressed or implied warranties or representations, including any implied warranties of merchantability or fitness or any obligations on the part of Ridewell. Ridewell will not be liable for any business interruptions, loss of profits, personal injury, any costs of travel delays or for any other special, indirect, incidental or consequential losses, costs or damages.

Contact the Ridewell Warranty Dept. at 417.833.4565 - Ext. 135, for complete warranty information.