

RAR-260

Trailer Air-Ride Suspension

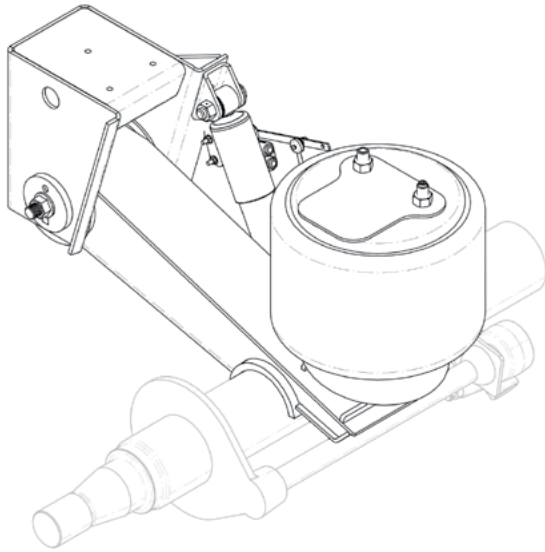

Installation and Service Manual

Suspension Identification	2
Prior to Installation	3
Axle Integration	4
Suspension Mounting	6
Height Control Kit Installation – Troubleshooting	7
Maintenance	
Recommended Service Intervals	8
Suspension Components	
25K Overslung Suspension Components	
30K Overslung Suspension Components	9
15K Underslung Suspension Components	
25/30K Underslung Suspension Components	10
25K Underslung Suspension with integrated lift	
25K Yoke-Mount Suspension	11
Hanger Mount Suspension – Bushing Replacement	12
Yoke-Mount Suspension – Bushing Replacement	14
Axle Alignment	15
Warranty	16



SUSPENSION IDENTIFICATION

Introduction

The Ridewell Air Ride (RAR) 260 Trailer Suspension System is available in overslung, underslung or yoke-mount configurations.

The suspension system can be purchased with or without an integrated axle.

Suspension Identification Tag

The **Part Number** is listed as a (606-) Installation/ Assembly Number when an axle and other system components are factory installed onto the suspension.

The **Suspension Number** and **Serial Number** lists the suspension model and date of manufacture.

Please refer to the suspension number/part number and serial number on the Suspension Identification Tag when contacting Ridewell for customer service, replacement parts and warranty information.

Axle-Body Identification Tag

The **Base-Axle Part Number (165-)** and the **Serial Number** identifies Ridewell-branded round axles manufactured in various axle-wall thicknesses and track widths.

More information on Ridewell-branded axles can be found in the "Trailer Axle Parts Guide" (9710029).

Notes and Cautions

All work should be completed by a trained technician using proper/special tools and safe work procedures. Read through the entire Installation and Service Manual (ISM) before performing any procedure.

The ISM uses two types of service notes to provide important safety guidelines, prevent equipment damage and ensure the suspension system operates correctly.

The service notes are defined as:

"NOTE": Provides additional instructions or work procedures to complete tasks and ensure suspension components function properly.

CAUTION Indicates a hazardous situation or unsafe practice that, if not avoided, could result in equipment damage and serious injury.

 RIDEWELL SUSPENSIONS The Engineered Suspension Company	
PART NO:	
SUSP. NO:	
SERIAL NO:	
GROSS AXLE WEIGHT RATING CERTIFICATION IS PER THE FINAL STAGE MANUFACTURER OR ALTERER.	
THIS PRODUCT MAY BE COVERED UNDER ONE OR MORE PATENTS, ADDITIONAL PATENTS MAY BE PENDING.	
www.ridewellcorp.com	(800) 641-4122

The Suspension Model (Suspension Number) and date of manufacture (Serial Number) are listed on the Suspension Identification Tag.

 RIDEWELL SUSPENSIONS			
MODEL:		PART NO.	
SERIAL NO.		CAPACITY	TON

The Base-Axle Part Number (165-) and the Serial Number assigned to the axle tube are listed on the Axle-Body Serial Identification Tag.

Standard Trailer Dimensions				
Trailer	Track Width	Frame Center	Beam Center	Air Spring Center
96"	71.5"	38"	35"	31"
102"	77.5"	44"	41"	37"

Prior to Installation

Refer to the suspension model engineering drawing for system components details; available ride heights; dimensional requirements; and, operating parameters. The suspension fits onto I-beam trailer frames on beam centers at standard axle track widths (Chart).

Installation at wider beam centers will reduce suspension clearances. Installation at narrower beam centers will de-rate the axle beam capacity.

The installer is responsible for verifying clearances, axle capacity, proper fit-up, and additional required support structure for non-standard beam centers, frames, frame centers, axle track widths and wheel-end equipment.

Installations can vary and should be adapted as needed.

- The Gross Axle Weight Rating (GAWR) is determined by the system component with the lowest load rating. Consult tire, wheel, axle and brake manufacturers to determine the GAWR.
- If vehicle chassis modifications are required, consult with the vehicle manufacturer to ensure that such changes are permitted.
- Welding or altering of suspension components is not permitted without the express written permission of Ridewell Suspensions.

Installer Responsibilities

The suspension installer has the sole responsibility for the proper attachment of the suspension system to the vehicle chassis.

- The installer is responsible for locating the suspension system on the vehicle to provide the proper load distribution.
- The installer must verify that vehicle crossmembers are positioned to support the suspension at the installing location.
- It is the installer's responsibility to determine that axle spacing conforms to any applicable federal and local bridge laws.
- The installer must verify that air reservoir volume requirements are met after installation. Consult the vehicle manufacturer or Federal Motor Vehicle Safety Standards (FMVSS) 121 for more information.
- The installer must verify there is sufficient clearance for proper functioning of the suspension, air springs, brake chambers, axle and tires.

Axle Integration

Suspension systems are available with and without a factory integrated axle. Customer-supplied axle assemblies must be positioned and oriented (rotated) properly before welding the axle to the axle seats.

Use the top-center mark on the axle, if available, to identify the center of the axle and orient the axle assembly on the suspension.

The axle assembly should be installed so that the camshafts, when activated, rotate in the same direction as the wheels.

CAUTION Failure to follow procedures and design specifications could result in injury, damage to the axle or suspension and void the warranty.

Weld Preparation

The joint to be welded should be positioned in the flat or horizontal position. All grease, dirt, paint, slag or other contaminants must be removed from the weld joint.

The axle and suspension components should be at a minimum temperature of 60°F (15.5°C). Pre-heat the weld zone to the axle manufacturer's recommended pre-heat temperature, if required.

Weld Procedure

Ridewell recommends supporting the axle and suspension with a weld fixture during axle integration. Contact Ridewell Customer Service for the correct weld fixture for your suspension model.

1. Center the axle assembly on the beam centers (Figure 1).
2. Check the engineering drawing for the brake component orientation (rotation) before clamping into place and making the final welds.
 - 2.1 Drum brake camshafts are spaced off the tail of the trailing arm beam. Make sure the brake chamber brackets are oriented properly and clamp the axle assembly into place.
 - 2.2 Disc brake assemblies have a right- and left-hand caliper assembly. Make sure the callipers are located on the correct side and rotated to the proper position before clamping the axle assembly into place.
3. Check the gap between the axle and the axle seats before welding. Side gaps should be no greater than 1/8". The gap at the bottom of the axle seat should be no greater than 1/16" (Figure 2).
4. Weld the axle to the seat according to Ridewell Weld Process #1 (Page 5).

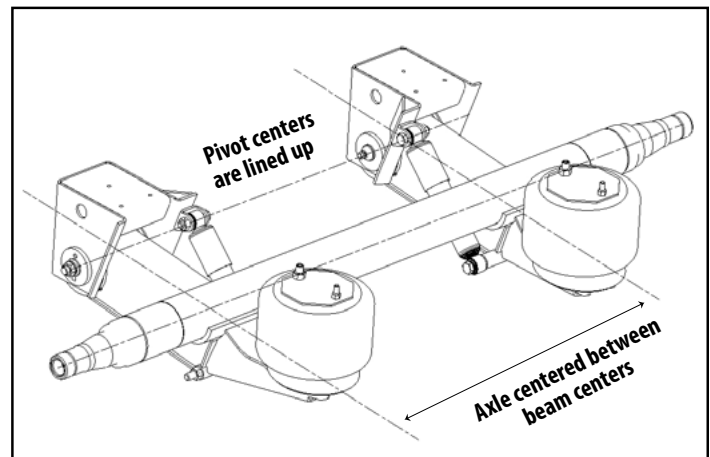

Figure 1.
Axle should be centered between beams with beams and axle perpendicular to each other. Refer to the engineering drawing for measurements.

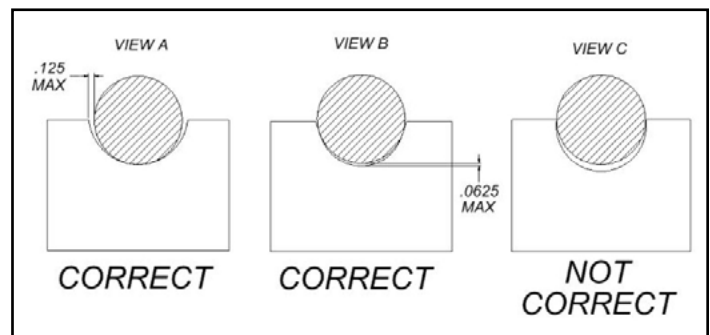
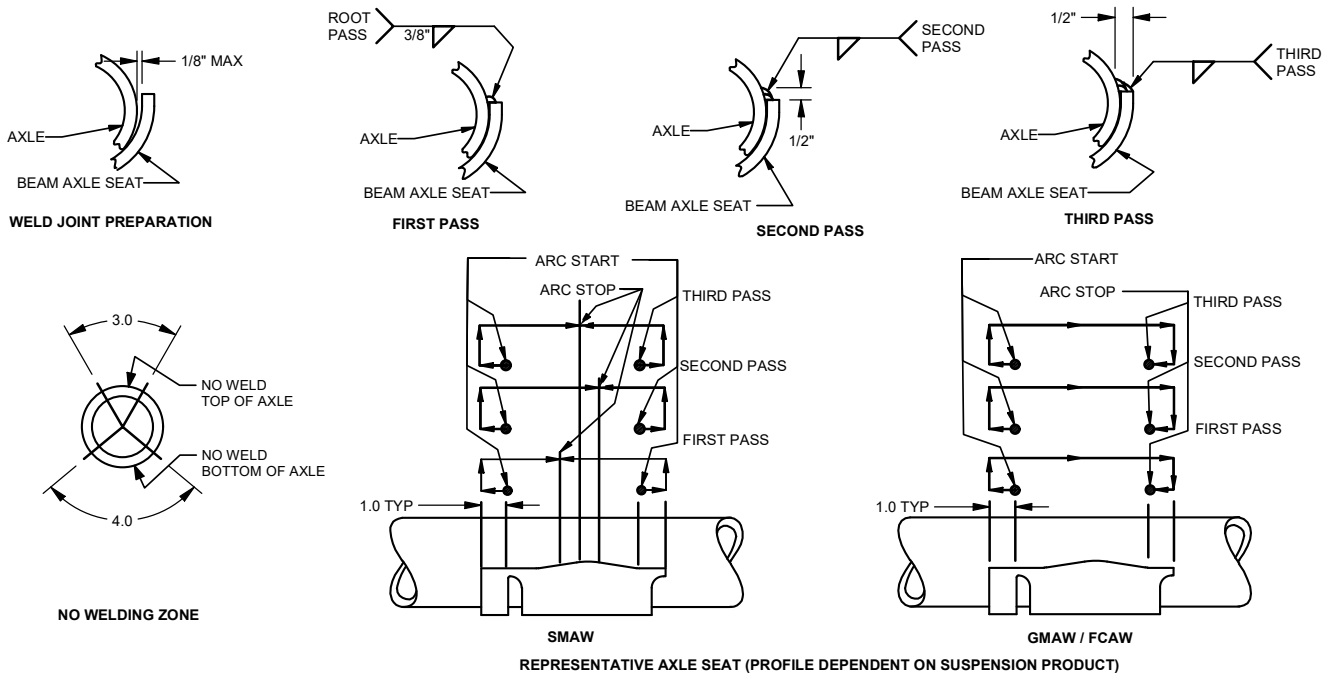
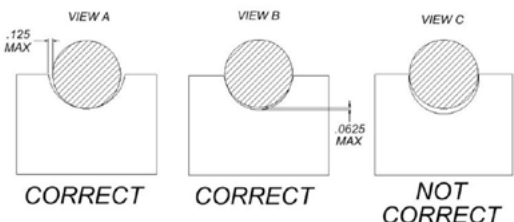

Figure 2.
Correct axle tube seating for welding.



- 1 - CAUTION: All welds must be kept away from the top and bottom of the axle where maximum stresses occur (see "NO WELDING ZONE" illustration above). Do not test-weld the arc on any part of the axle tube.
- 2 - All welders and welding operators should be certified as per the requirements of the American Welding Society (AWS) or equivalent. All electrodes used should meet the AWS specifications and classifications for welding carbon and low-alloy steels.
- 3 - Recommended Welding Methods: Shielded Metal Arc Welding (SMAW), Gas Metal Arc Welding (GMAW) or Flux Cored Arc Welding (FCAW). The welding method used and the electrode selected must develop a minimum weld tensile strength of 70,000 psi per AWS specifications. The best fusion and mechanical properties will be obtained by using the voltage, current, and shielding medium recommended by the electrode manufacturer. If the SMAW method is used, the stick electrodes must be new, dry, free of contaminants and stored per AWS specifications.
- 4 - Weld Joint Preparation: The joint to be welded should be positioned in the flat or horizontal position. All grease, dirt, paint, slag or other contaminants must be removed from the weld joint without gouging the axle tube. CAUTION: Never weld when the axle is cold. The axle and beam assemblies to be welded should be at a temperature of at least 60°F (15°C). Pre-heat the weld zone to the axle manufacturer's recommended pre-heat temperature, if required. This will reduce the chance of an area of brittle material forming adjacent to the weld.
- 5 - The axle should fit into the beam assembly with a maximum root gap of 1/8-inch between the axle and the beam axle seat (see "WELD JOINT PREPARATION" illustration above).
- 6 - NOTE: Clamp the axle to the beam axle seat with a C-clamp prior to welding to make sure that proper contact occurs (see "CORRECT" illustration below).
- 7 - Ground the axle to one of the attached axle parts such as the brake chamber brackets, cam brackets or brake spider. Never ground the axle to a wheel or a hub as the spindle bearing may sustain damage.
- 8 - Multiple pass welding should be used on the beam/axle connection using the following guidelines:
 - 8.1-Total fillet weld size should be 1/2-inch.
 - 8.2-Weld pass starts and stops should be performed as illustrated above.
 - 8.3-Never start or stop welds at the end of the weld joint.
 - 8.4-Each pass must be accomplished in one or two segments.
 - 8.5-Start welds at least 1-inch from the end and backweld over the start. Backstep fill all craters.
 - 8.6-If process is not GMAW all slag must be removed between passes.
 - 8.7-Welds must go to within 1/8-inch +/- 1/16-inch of the ends of the axle seat and must not go beyond or around the ends of the axle seat.
 - 8.8-Post-weld peening is recommended, but not required: Needle peen the entire toe of the second pass, including around the ends of the axle seat. Hold the needles perpendicular to the axle. A uniform dimpled pattern will appear when properly peened.



G	22101	REVISED "NO WELDING ZONE" DETAIL	11/7/22	AAS	BB	CJB
F	16101	ADDED MAXIMUM TO 5, ADDED GMAW NOTE TO 8.6 UPDATED CORRECT VIEWS	2/10/2016	G.H.	B.B.	CJB
REV	PROJ/ECR	DESCRIPTION	DATE	BY	CHK	APPD
DRAWN BY:	CBC	11/7/2022	RIDEWELL CORPORATION PO BOX 4586 SPRINGFIELD, MISSOURI 65808			
CHECKED:	MDJ	2/21/2003				
APPROVED:	CJB	2/21/2003				
PROJECT NO:	03103	SCALE: A-SIZE: NTS	TITLE: RIDEWELL WELD PROCESS #1, 5" DIA. AXLE, 3 PASS WELD			
MATERIAL:	-	WEIGHT:	-	SHEET 1 OF 1		REV: G
			PART NO: WELD PROCESS #1			

Suspension Mounting

Refer to the engineering drawing for available ride heights; the recommended locations of any customer-furnished filler plates and supporting crossmembers; the torque values; and the spacing and clearance requirements of suspension components.

The suspension installer has the final responsibility of attaching the suspension to the vehicle frame.

Weld-On Installation Procedure

CAUTION Welding method must use a minimum weld tensile strength of 70,000 psi, per AWS specifications.

1. Mark the desired location of the hangers and filler plates on the vehicle frame.
Hangers must be installed parallel to each other for proper axle alignment.
2. Mark the desired location of the air spring mounting plates and filler plates on the frame.
3. Install filler plates for the hangers and air spring mounting plates on the frame. Weld filler plates to crossmembers with 1/4" fillet welds down the length of the crossmember.
4. Weld the hangers to the frame/filler plates with 1/4" fillet welds completely around the hangers. Stop the welds 1/2" from the corners and edges.
 - 4.1 For hangers with wing gussets, the wing gussets must be welded to a crossmember or other supporting structure.
 - 4.2 A length of 1 1/2"-diameter pipe can be placed through the holes in the two hangers to help with stabilization and alignment.
5. Weld the air spring mounting plates to the frame/filler plates with 3/16" fillet welds.
6. Attach a crossmember or diagonal brace to the front of the hangers with 1/4" fillet welds.

Bolt-On Installation

Before installation, check to make sure that wires, hoses or other components will not be affected by drilling into the frame rail.

- Bolts/nuts for attaching the suspension to the vehicle are supplied by the installer. Grade 8 bolts and flanged locknuts or locknuts with hardened washers are recommended.
- Bolt holes are not provided in the air spring mounting plates. Clamp mounting plates and filler plates (if necessary) in place before drilling.

Final Assembly and Inspection

- Verify the welds of the hanger and air spring mounting plates.
- Check the location for sufficient clearances of suspension components.
- Attach beam and axle assemblies to hangers. Note: Do not fully torque pivot hardware until axle alignment is completed (pg 12).

CAUTION Do not apply undercoating; paint or other top coat to suspension; frame hangers; or pivot connection hardware until axle alignment procedure is completed.

NOTE: Areas where metal surfaces of alignment plates; washers; pivot bolts/nuts or pivot bushing (bushing sleeve) contact the frame hanger must be masked if applying under- or top coating prior to suspension assembly (Figure 3).

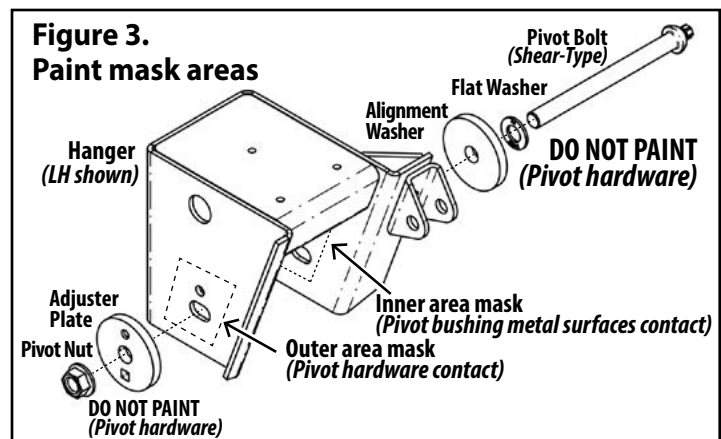

- Complete assembly and installation of air springs as shown on the engineering drawing. Torque to specifications (Page 12).
- Install/connect the height control valve (HCV), if applicable. Check the air system tubing and fittings after installation for leaks (Page 7).
- Verify suspension ride height is adjusted within range shown on engineering drawing. Complete axle alignment procedure (Page 15).
- Install shock absorbers.
NOTE: If the suspension is painted after shocks are installed, make sure paint overspray does not get under the shock absorber dust covers.

CAUTION Failure to torque suspension components to specifications can result in suspension failure and void the warranty.

The Ridewell Extreme Air® Height Control Kit (HCK) adds and exhausts air from the air springs to maintain vehicle ride height. The HCK assembly consists of one lever connected to the height control valve (HCV) with a rod arm (vertical link) connected to the lower mounting bracket (Figure 4).

Refer to Installation Guide 9710008 for installation procedures and HCK configurations for different suspension applications. The vehicle's entire air system should be checked for leaks after any height control kit installation.

CAUTION The installer is responsible for making sure that the air system requirements comply with all appropriate Federal Motor Vehicle Safety Standards.

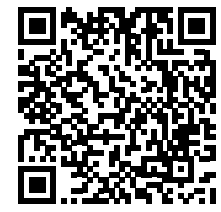
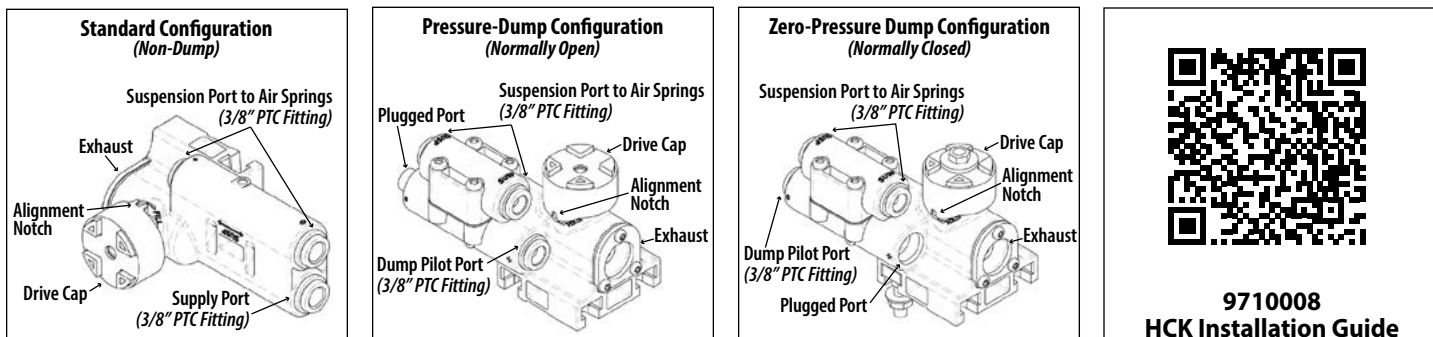

**9710008
HCK Installation Guide**

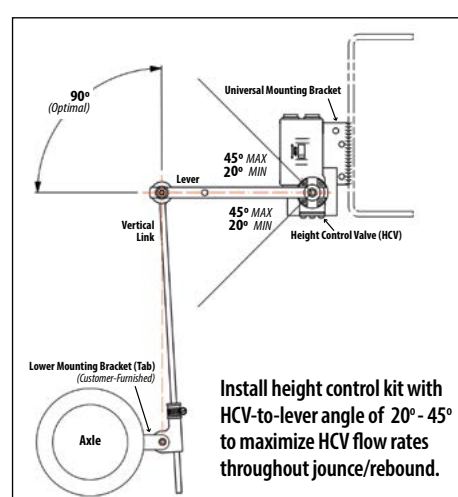
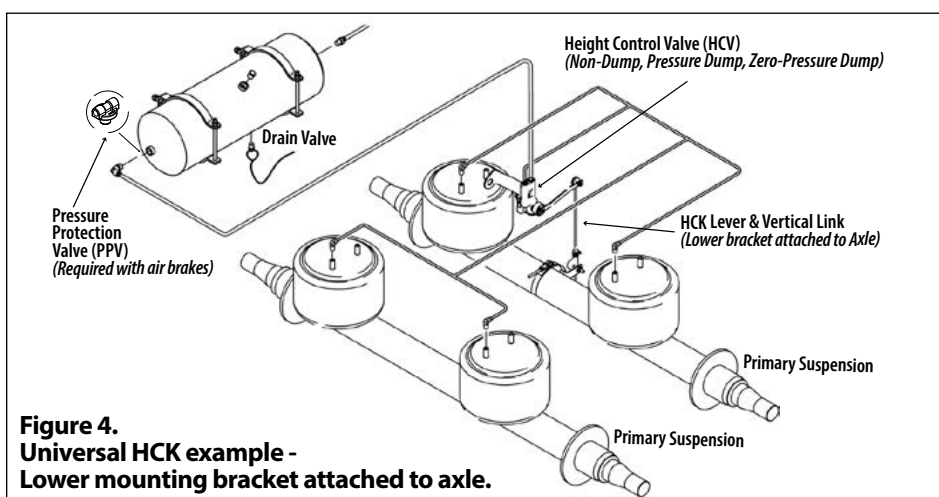

Install height control kit with HCV-to-lever angle of 20° - 45° to maximize HCV flow rates throughout jounce/rebound.

HEIGHT CONTROL KIT INSTALLATION – TROUBLESHOOTING

Problem	Possible Cause	Corrective Action
HCV is not receiving air.	<ul style="list-style-type: none"> Blocked air supply line. 	<ul style="list-style-type: none"> Verify air lines are pressurized by removing supply line at HCV. Check for pinched lines.
HCV is not delivering air to the air springs.	<ul style="list-style-type: none"> Air tank not filling/reaching set pressure. Pressure Protection Valve (PPV) not working correctly. Pilot port is not plumbed or is plumbed incorrectly. 	<ul style="list-style-type: none"> Verify air tank pressure with manual/in-line pressure gauge. Check PPV operation by making sure valve opens when system reaches the desired pressure setpoint (<i>usually greater than 70 psi</i>). Check HCV configuration and reinstall if necessary – Non-Dump; Pressure-Dump (Normally Open); Zero-Pressure Dump (Normally Closed).
Air springs fill but do not exhaust.	<ul style="list-style-type: none"> Obstructed air line. HCV installed backwards. Supply line installed to suspension port 	<ul style="list-style-type: none"> Disconnect linkage. Rotate lever to down position (exhaust). If springs remain inflated, check for pinched/blocked lines. Check installation. Reinstall, if necessary. Move air supply line to HCV supply port.
Air system leaks down in a short period of time.	<ul style="list-style-type: none"> HCV installed backwards. Leak in air system beyond accepted standards. 	<ul style="list-style-type: none"> Disconnect linkage to HCV. Turn lever to the up position (fill). If air springs do not inflate, reinstall height control valve. Check air system for leaks. To find leak in the HCV area, pressurize system and spray soapy water solution onto the valve and lines. Check for bubbles (leaks): <ul style="list-style-type: none"> No leak found – Do not remove valve, check rest of system for leaks. Check that tubing cuts are straight and smooth. Re-cut and reassemble if necessary.

Recommended Service Intervals

Ridewell Suspensions recommends the following minimum service intervals for standard duty, on-highway usage applications. More frequent intervals are recommended for heavier duty applications.

Daily/Pre-Trip Inspections

- ___ Check tires for proper inflation, damage or excessive wear.
- ___ Check wheel-ends for obvious signs of lubricant leakage. Check for missing components.
- ___ Check axle assemblies for damage or loose components.
- ___ Visually inspect suspension structure for signs of damage or excessive wear.
- ___ Check for loose or missing bolts/nuts. Check for irregular movement in suspension components.
- ___ Make sure air controls are operating properly. Drain all moisture from air reservoirs.

First 6,000 miles of use

- ___ Torque suspension components to specifications (Page 12/Engineering Drawing).
NOTE: Do not re-torque shear-type pivot bolt.
- ___ Verify that suspension is operating at the installed ride height.

Refer to these Technology & Maintenance Council (TMC) publications for additional information

RP 609	Self-Adjusting/Manual Brake Adjuster Removal, Installation and Maintenance
RP 618	Wheel Bearing Adjustment Procedure
RP 619	Air System Inspection Procedure
RP 622	Wheel Seal and Bearing Removal, Installation, and Maintenance
RP 631	Wheel End Lubrication Recommendations
RP 643	Air Ride Suspension Maintenance
RP 728	Trailer Axle Maintenance

Every 12,000 miles of use

- ___ Inspect air springs for damage/excessive wear. Torque air spring bolts/nuts to specifications (Page 12/Engineering Drawing).
- ___ Check air lines and connections for leaks.

Every 50,000 miles of use

- ___ Torque suspension components to specifications (Page 12/Engineering Drawing).
NOTE: Do not re-torque shear-type pivot bolt.

Annually/100,000 miles of use

- ___ Inspect pivot connection for worn pivot bushing and wear washers. Replace if necessary.
- ___ Torque component bolts/nuts to specifications (Page 12/Engineering Drawing).
- ___ Check arm beam-to-axle connection welds.

Check lubrication level in wheel ends:

- ___ **1) Oil-Filled Wheel Ends:**
Refill/Replace lubricant as needed
(TMC RP 631-“100K/Annual Inspection”).
- ___ **2) Semi-Fluid Grease:**
Pull outer bearing and visually inspect the lubrication level. Refill/Replace as needed
(TMC RP 631-“Level 3 Lubrication Level Inspection”) (TMC RP 618-“Wheel Bearing Adjustment Procedure”).
- ___ Check air lines and connections for leaks.
- ___ Test air control system pressure protection valve (PPV), if equipped.
- ___ Check height control valve (HCV) adjustment.
- ___ Verify suspension operating at installed ride height.

CAUTION Failure to torque suspension components to specifications can result in suspension failure and void the warranty.

Pivot Bushing Inspection Procedure

Park the unloaded trailer on a level surface. Set the brakes and chock the tires so vehicle cannot move during inspection.

Insert the flat end of a pry-bar between one side of the hanger sidewall and the wear washers. Move the pry-bar back-and-forth and look for excessive movement of the beam (NOTE: A small amount of beam

movement because of the rubber flexing is normal). Inspect the wear washers for excessive wear/damage.

Repeat the pry-bar process and wear washer inspection on the other side of the hanger. If any large/easy movement or damaged wear washers is observed, drop the beams for further inspection. Replace components as necessary.

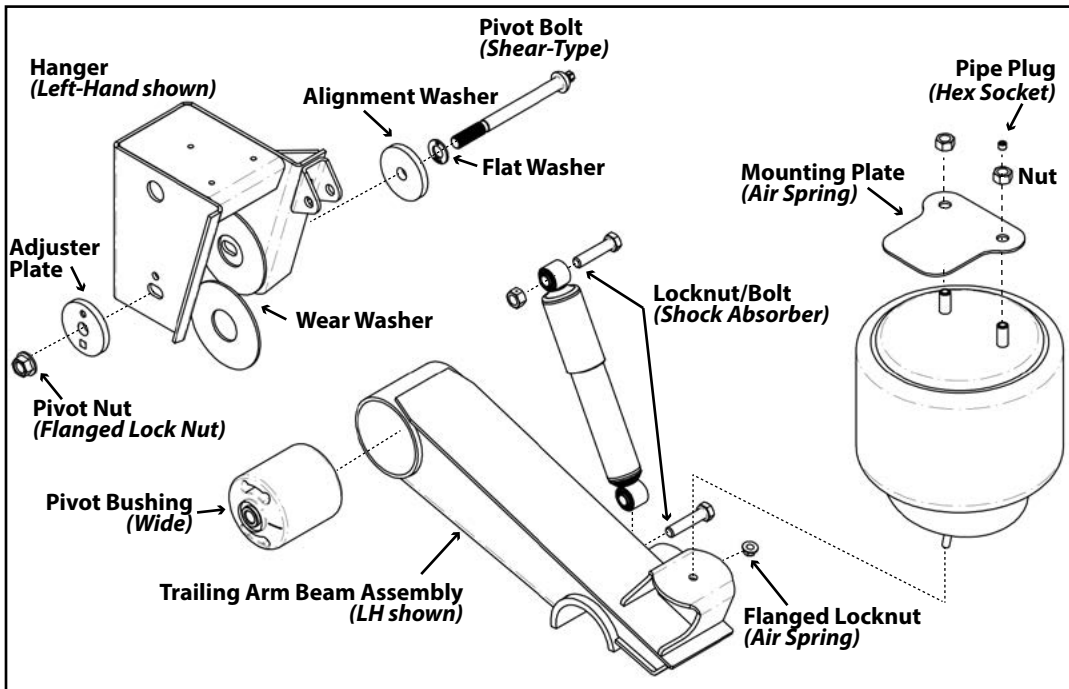

Figure 5.
260-25K
Overslung Suspension
 Refer to suspension model engineering drawing for component part number.

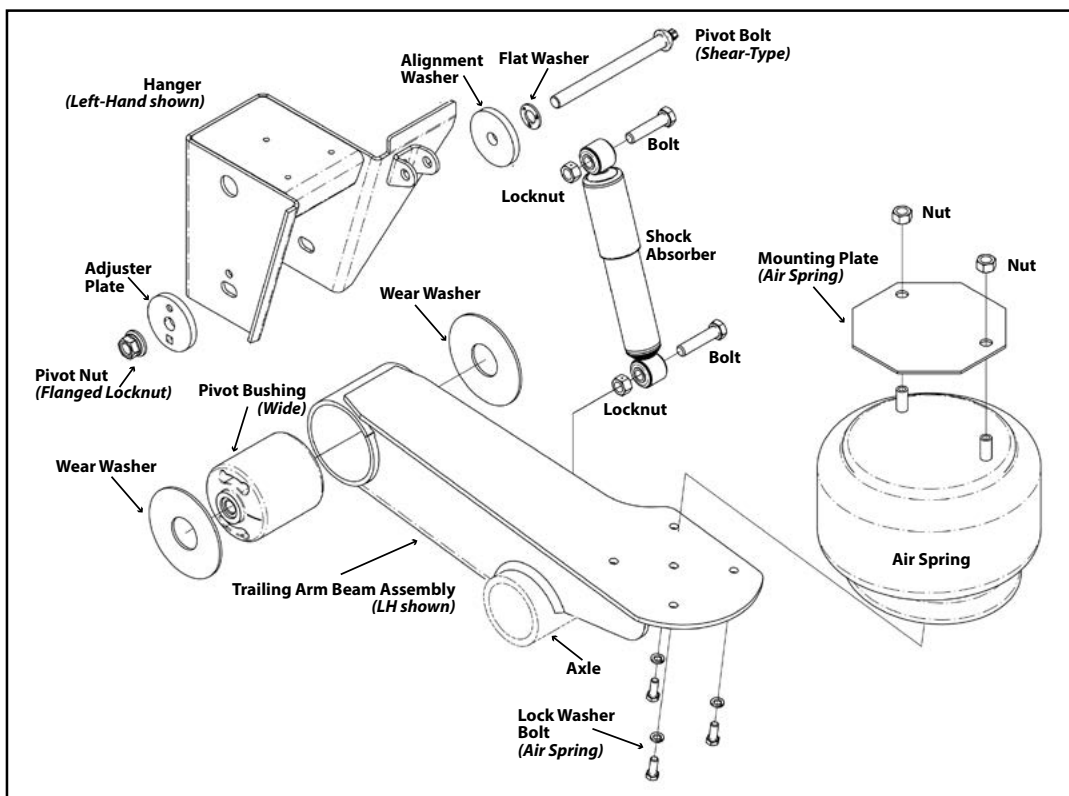

Figure 6.
260-30K
Overslung Suspension
 Refer to suspension model engineering drawing for component part number.

Figure 7.
260-15K
Underslung Suspension
 Refer to suspension model
 engineering drawing for
 component part numbers.

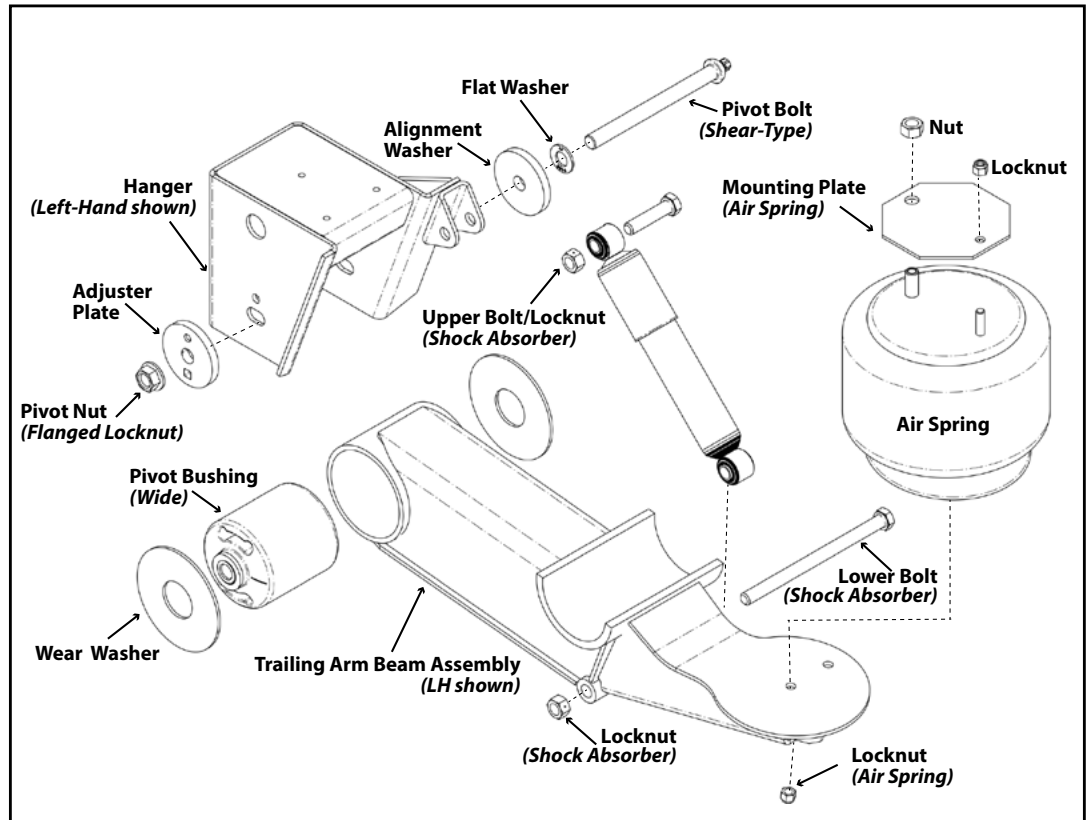
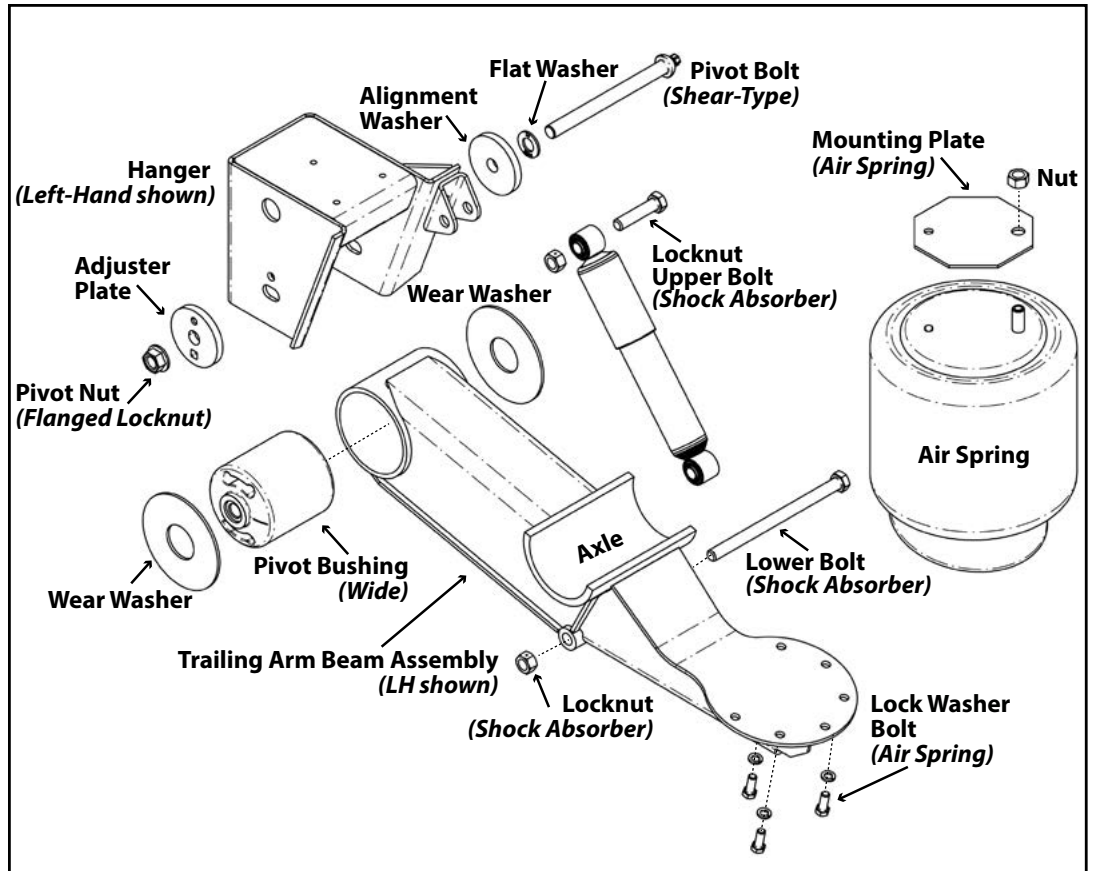

Figure 8.
260-25/30K
Underslung Suspension
 Refer to the suspension
 model engineering
 drawing for component
 part numbers.



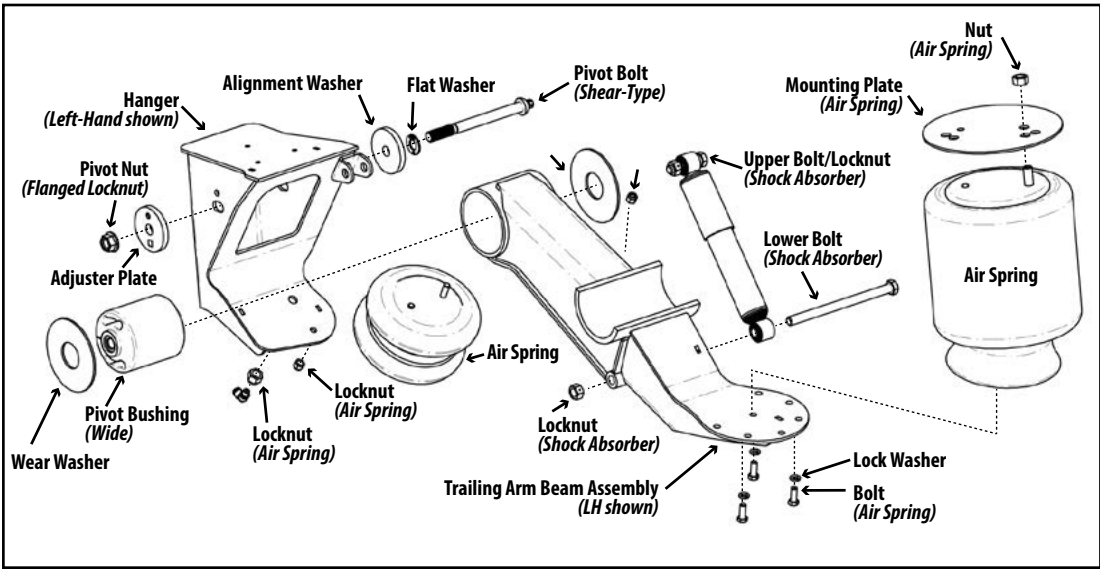

Figure 9.
RAR 260 25K
USW with integrated lift

Refer to the suspension
model engineering
drawing for component
part numbers.

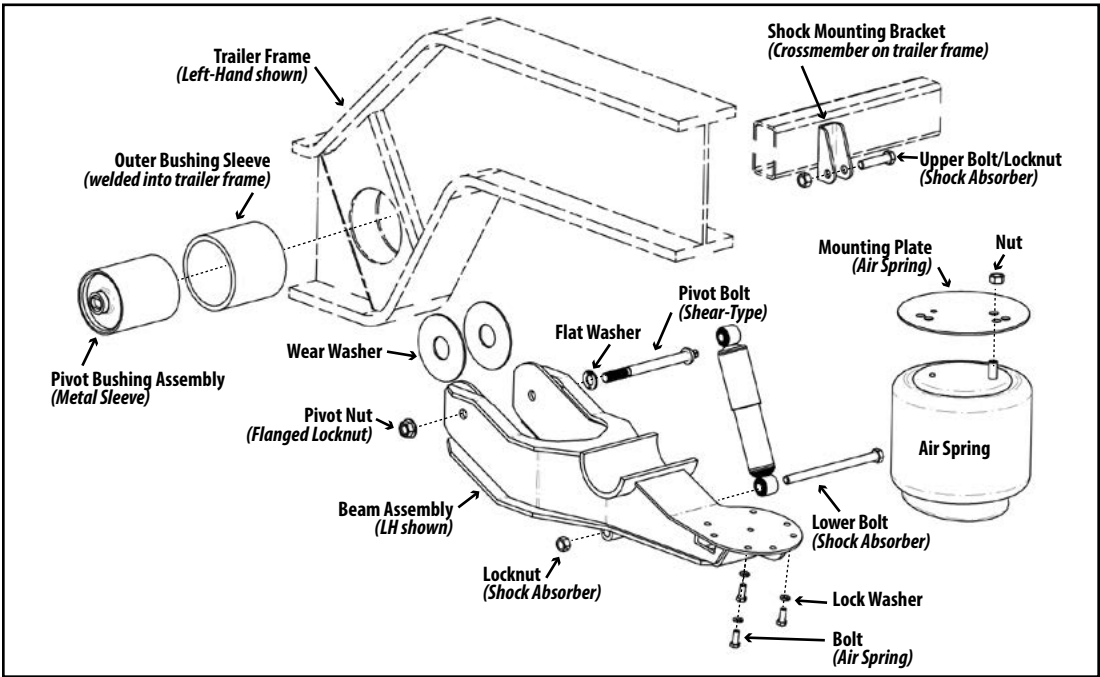

Figure 10.
260-25K
Yoke Mount Suspension

Refer to the suspension
model engineering
drawing for component
part numbers.

HANGER MOUNT SUSPENSION — BUSHING REPLACEMENT/TORQUE SPECIFICATIONS

Component P/N	Item Description	Size	Torque Values	
			foot-pound	Newton-meter
6040098-Bushing Kit 6100051-Wide Tool	Pivot Bolt/Nut-(Shear-Type Bolt/Locknut) <i>Requires E-20 Torx® socket (RW #6100054)</i>	7/8"-9NC	<i>Do not lubricate bolt/nut threads. Use 1"-drive impact wrench to tighten until Torx® head shears off.</i>	
Fasteners	Locknut - (Air Spring)	1/2"-13NC	20-25 ft-lb	27-34 N-m
	Bolt - (Air Spring)	1/2"-13NC	20-25 ft-lb	27-34 N-m
	Nut - (Air Spring)	3/4"-16NF	45-50 ft-lb	61-68 N-m
	Locknut - (Air Spring-25K O/S)	1/2"-13NC	45-50 ft-lb	61-68 N-m
	Locknut - (Shock Absorber)	3/4"-10NC	200-230 ft-lb	271-312 N-m

Torque values reflect a lubricated thread condition (Nuts are pre-lubed). Do not overtorque.

CAUTION Suspension is shipped with minimal torque applied to fasteners. All fasteners must be re-torqued after first 6,000 miles of operation. Failure to install and maintain fasteners at torque specifications could result in suspension failure and void the warranty.

Vehicle Preparation

Park the vehicle on a level surface. Chock wheels to keep vehicle from moving. Raise vehicle to a height that removes the load from the suspension. Support with jack stands.

Disconnect linkage from the height control valve(s), if equipped. Exhaust all air from the system.

CAUTION Failure to properly chock wheels, exhaust air system and safely support the vehicle could allow movement that could result in serious injury.

Disassemble the suspension

Remove wheels and tires, if necessary. Remove the shock absorbers.

Take pivot connections apart. Discard pivot bolt, flat washer and pivot nut. Inspect adjuster plate and alignment washer for wear/ damage. Replace if necessary.

CAUTION Do not reuse pivot hardware.

Rotate beams out of the hangers. Inspect pivot-bolt holes and hanger surfaces for unusual wear/damage. Repair or replace suspension components as needed.

Tool Assembly

Make sure thrust washer is seated firmly in the flat (outside) edge of the end cap.

Examine tapered insert and tool cone end for damage/ out-of-round. Repair/replace as need (Fig 12).

Bushing Removal

1. Draw/scribe line on the beam using locator mark on installed bushing as reference (Fig 11).

2. Lubricate the hex-head bolt threads and the thrust washer bearings with Extreme Pressure Lube (P/N 1980014).
NOTE: Failure to apply lubricant could result in decreased performance and reduced tool life.

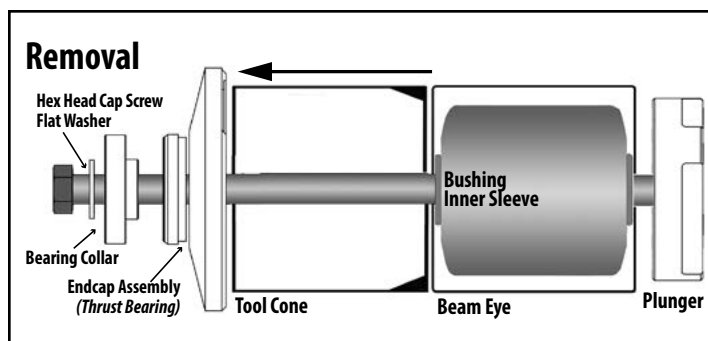
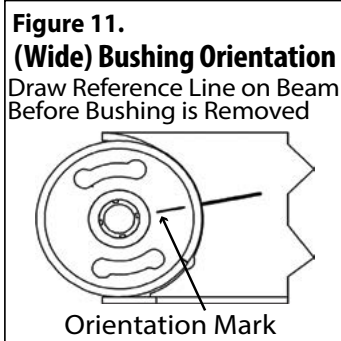

Figure 12.
Bushing Replacement Tool #6100051.

- Place flat washer onto the hex-head bolt, followed by the bearing collar, then the end cap assembly.
- The bushing tool cone is tapered inside to a smaller opening on one end. Place the larger opening of the cone onto the end cap.
NOTE: The tapered end of the cone is always placed on the eye of the beam.
- Insert the end of the hex bolt through bushing sleeve into the center opening of plunger. Center cone on the beam eye. Tighten the hex bolt until plunger is held firmly against the bushing.
- Use a 1 5/16" socket on a 3/4"-drive impact wrench (1"-drive impact wrench recommended) to rotate the hex bolt and press the bushing out of the beam eye into the cone.
NOTE: In some cases, a small amount of heat may be required to break the bond between the bushing and the beam eye. Do not overheat. Allow the beam to cool before installing replacement bushing.
- Disassemble the bushing tool. Remove bushing from the bushing tool cone and discard.

Tool Assembly-Installation

Place flat washer, bearing collar, and end-cap onto the hex-head bolt.

continued on next page

Replacement Procedure with Bushing Tool #610051 (continued)

Insert smooth end of each Cavity Alignment Stud (Socket Head Cap Screw-SHCS) into the four holes on the outside edge of the bushing tool plunger.

Tighten alignment stud (SHCS) until the socket head(s) is flush with the edge of the plunger.

NOTE: Smooth end(s) of the stud should extend beyond the inside edge of plunger (Figure 13).

Bushing Installation

1. Use wire brush to clean beam eye.
2. Coat inside of beam eye, the outside of bushing and inside the tool cone with S.G. Type "M" Rubber Assembly Oil.
NOTE: Do not substitute lubricant. Type "M" Oil included with all bushing replacement kits.
3. Insert replacement bushing into large end of tool cone. Make sure bushing locator-mark is visible.
4. Line up locator-mark on tool plunger with the bushing locator mark. Insert the four cavity alignment studs into bushing cavity holes and press the plunger firmly against the end of the bushing.
NOTE: The threads of the SHCS should NOT touch the bushing (Figure 13).
5. Align plunger locator mark with the line drawn/scribed on the beam. Place the plunger/cone/bushing assembly onto the beam eye.
6. Insert the hex-head bolt assembly through the beam eye. Thread the hex bolt into the plunger until the end-cap rests against the beam.
7. Center tool cone on the beam eye. Use a 1 5/16" socket and 3/4-drive impact wrench (1"-drive wrench recommended) to rotate the hex-head cap screw and press bushing into the beam eye.
8. Disassemble and remove bushing tool. Check placement to ensure bushing is centered in beam.
9. Check bushing locator-mark against line on the beam to ensure bushing is properly oriented.

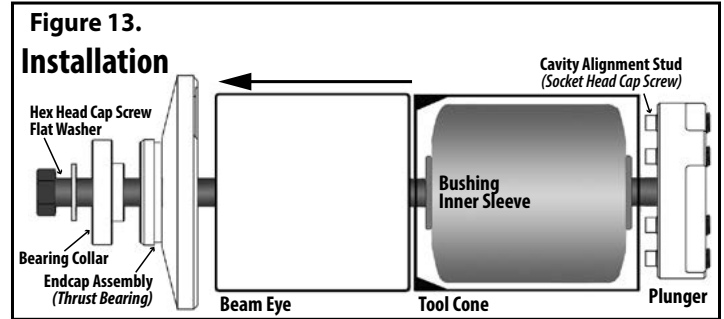

Reassemble suspension

Rotate the beams into hangers. Assemble pivot connection–alignment washer, adjuster plate, wear washers, shear-type pivot bolt, flat washer and locknut.
NOTE: Do not lubricate pivot bolt/nut. Tighten flanged locknut until adjuster plate pin is engaged and pivot connection hardware is snug against hanger. Do not apply final torque until axle alignment has been checked.

Connect height control valve linkage (if linkage has been disconnected). Inflate air springs.

Install wheels and tires (if removed). Raise vehicle and remove support stands. Lower vehicle to ground.

Verify suspension ride height. Check axle alignment. Realign if necessary (Pg 15).

Tighten pivot bolt with a 1" drive impact wrench and E-20 Torx® socket (Ridewell tool #6100054) until Torx® head is sheared off.

Install shock absorbers.

CAUTION Failure to torque hardware to specifications can result in suspension failure/void the warranty.

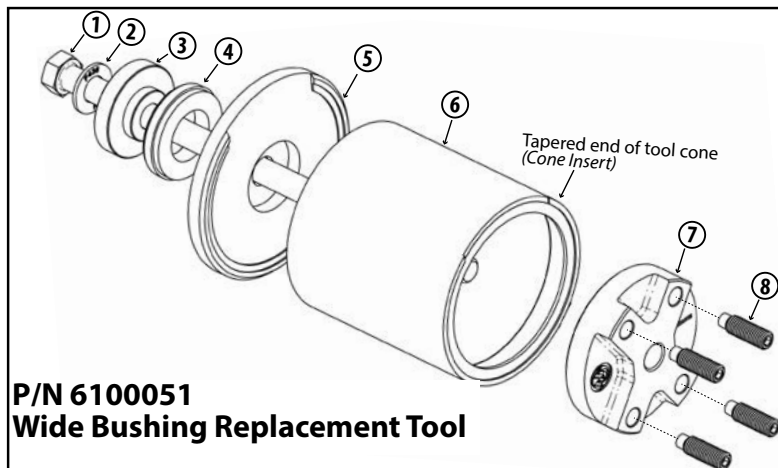

No.	Part No.	Item Description
1	1130088	Hex Head Cap Screw (HHCS)–7/8"–6 Acme; 18"
2	1160036	Flat Washer 7/8" – F436 Zinc/Coated
3	1120051	Bearing Collar – Bushing Tool
4	1660009	Thrust Bearing
5	6100086	End Cap – Wide Bushing Tool
6	6100083	Cone Assembly – Wide Bushing Tool
7	6100087	Plunger – Wide Bushing Tool
8	1130087	Cavity Alignment Stud (SHCS) 5/8" – 11x2"
—	1980014	Extreme Pressure Lubricant

P/N 6100051
Wide Bushing Replacement Tool

YOKE-MOUNT SUSPENSION — BUSHING REPLACEMENT/TORQUE SPECIFICATIONS

Part Number (Component)	Item Description	Size	Torque Values	
			foot-pound	Newton-meter
6040099-Bushing Kit	Pivot Bolt/Nut - (Shear-Type Bolt/Locknut) <i>Requires E-20 Torx® socket (RW #6100054)</i>	7/8"-9NC	<i>Do not lubricate bolt/nut threads. Use 1"-drive impact wrench to tighten until Torx® head shears.</i>	
Fasteners	Locknut - (Air Spring)	1/2"-13NC	20-25 ft-lb	27-34 N-m
	Bolt - (Air Spring)	1/2"-13NC	20-25 ft-lb	27-34 N-m
	Nut - (Air Spring)	3/4"-16NF	45-50 ft-lb	61-68 N-m
	Locknut - (Shock Absorber)	3/4"-10NC	200-230 ft-lb	271-312 N-m

Torque values reflect a lubricated thread condition (Nuts are pre-lubed). Do not overtorque.

CAUTION Suspension is shipped with minimal torque applied to fasteners. All fasteners must be retorqued after first 6,000 miles of operation. Failure to install and maintain fasteners at torque specifications could result in suspension failure and void the warranty.

Vehicle Preparation

Chock wheels. Raise vehicle to height that removes load from suspension. Support with jack stands. Disconnect height control valve(s) linkage, if necessary. Exhaust all air from the air springs.

CAUTION Failure to properly chock wheels, exhaust air system, raise and safely support vehicle could allow movement that could result in serious injury.

Disassemble the suspension

Remove wheels and tires, if necessary. Remove the shock absorbers.

Take the pivot connections apart (see pg 11). Discard the pivot bolt, flat washer and pivot nut. Inspect alignment washer, adjuster plate and wear washers for wear/damage. Repair/Replace components as necessary. Rotate beam down and away from frame.

CAUTION Do not reuse pivot hardware.

Bushing Removal and Installation

- Grind away the four (4) welds on each side of the outer bushing sleeve. Remove pivot bushing assembly from frame. Inspect outer bushing sleeve for wear/damage. Repair or replace sleeve as needed.
- Position (center) replacement bushing assembly in the outer bushing sleeve. Align the bushing assembly center slot horizontally (Figure 14).
- Attach bushing assembly to vehicle frame with four (4) one-inch welds. Weld the top of the bushing sleeve at the outboard side of frame. Weld the bottom of sleeve at the inboard side of frame. Move the welds around sleeve in 90° increments.

NOTE: Excessive heat and distortion can damage the bond between the rubber bushing and the steel sleeve. Stagger the welds; and, allow the steel to cool between welds.

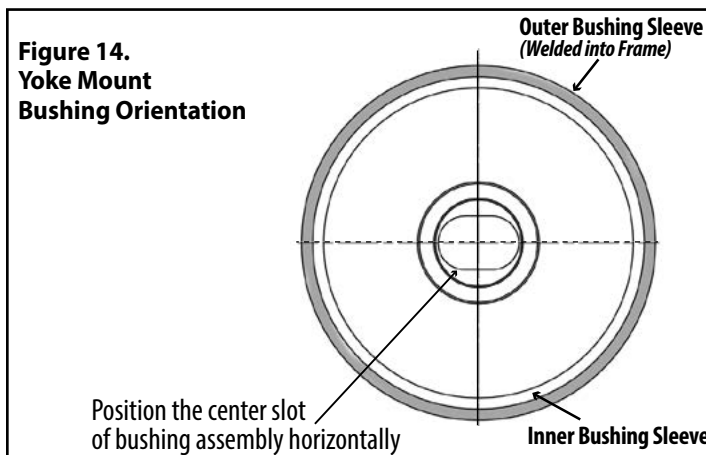

Reassemble suspension

Rotate beam(s) up onto frame. Install new pivot hardware and wear washers. Do not apply final torque until axle alignment has been checked.

Connect height control valve linkage; if linkage has been disconnected. Inflate air springs.

Install wheels and tires (if removed). Raise vehicle and remove support stands. Lower vehicle to ground.

Verify suspension ride height. Check axle alignment. Realign if necessary (Page 15).

Tighten pivot bolt with a 1"-drive impact wrench and E-20 Torx® socket (Ridewell tool #6100054) until Torx® head is sheared off.

Install shock absorbers.

CAUTION Failure to torque components to specifications can result in suspension failure and void the warranty.

Figure 15.
Kingpin measurement for axle alignment.

Check the forward axle alignment by measuring from the kingpin to both ends of the axle centers.

If the difference between the "A" measurement and the "B" measurement is greater than 1/8-inch, the forward axle needs to be aligned.

Adjust the aft axle if the difference between the "C" measurement and the "D" measurement is greater than 1/16-inch.

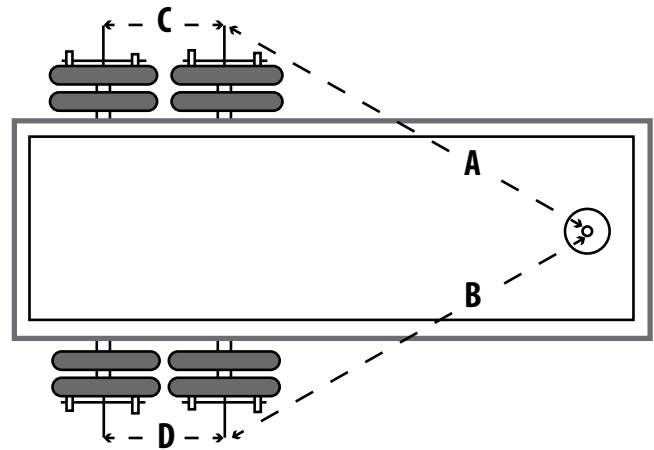

Align the suspension per TMC- or SAE-recommended standards. Alignment should be performed on a level surface with the suspension at the desired ride height.

On a multiple-axle vehicle, the forward axle is moved into proper alignment, then the remaining axles are positioned so they are parallel to the forward axle. A maximum tolerance of 1/8" difference from side-to-side of the forward axle and 1/16" difference from side-to-side for the aft axles is acceptable (Figure 15).

The RAR-260 suspension is equipped with Ridewell Speed Set® alignment for manual alignment.

Axle alignment procedure

1. Loosen the pivot nut enough for the beam to move within the hanger.

CAUTION Do not reuse pivot hardware if Torx® head is damaged/missing. A new pivot bolt, flat washer and locknut must be installed and the Torx head sheared off to complete the alignment.

2. Locate the adjuster plate at the pivot connection. Insert a 1/2"-shank breaker bar into the square hole of the adjuster plate. Push on the breaker bar to move the beam forward or backward until the axle reaches alignment measurements (Figure 16).

NOTE: Verify that the pivot bushing is not wedged sideways during beam movement. The adjuster plate and alignment washer should move in unison with beam movement.

3. Tighten the pivot nut so that the beam can no longer move. Re-check alignment measurements and adjust if necessary.

NOTE: Check to make sure both the adjuster plate and alignment washer are flat against the hanger before final torque is applied.

4. Tighten pivot bolt with a 1"-drive impact wrench and E-20 Torx® socket (Ridewell tool #6100054) until the Torx® head is sheared off.

CAUTION Failure to properly torque pivot hardware could result in suspension failure/void the warranty.

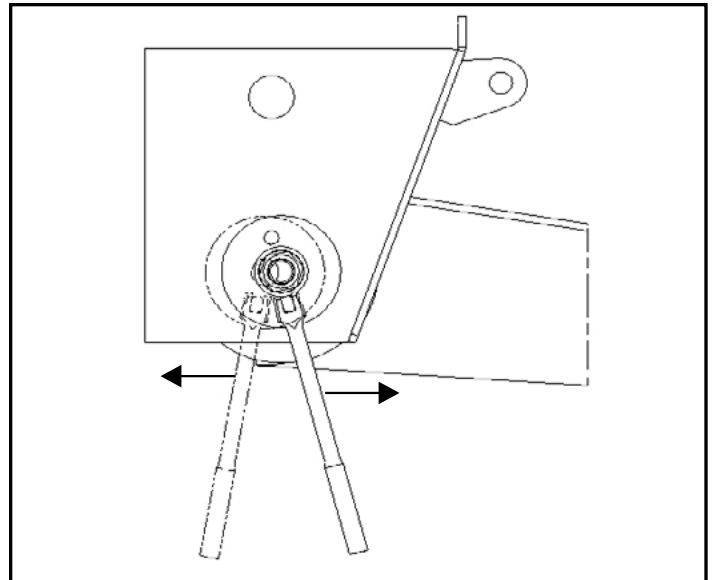

Figure 16.
Move beam back-and-forth using breaker bar until the axle reaches the desired position.

Terms and coverage in this warranty apply only to the United States and Canada.

Ridewell Suspensions warrants the suspension systems manufactured by it to be free of defects in material and workmanship. Warranty coverage applies only to suspensions that have been properly installed, maintained and operated within the rated capacity and recommended application of the suspension. The responsibility for warranty coverage is limited to the repair/replacement of suspension parts. The liability for coverage of purchased components is limited to the original warranty coverage extended by the manufacturer of the purchased part.

All work under warranty must have prior written approval from the Ridewell warranty department. Ridewell has the sole discretion and authority to approve or deny a claim and authorize the repair or replacement of suspension parts. All parts must be held until the warranty claim is closed.

Parts that need to be returned for warranty evaluation will be issued a Returned Materials Authorization (RMA). Parts must be returned to Ridewell with the transportation charges prepaid. The transportation charges will be reimbursed if the warranty claim is approved.

This non-transferable warranty is in lieu of all other expressed or implied warranties or representations, including any implied warranties of merchantability or fitness or any obligations on the part of Ridewell. Ridewell will not be liable for any business interruptions, loss of profits, personal injury, any costs of travel delays or for any other special, indirect, incidental or consequential losses, costs or damages.

Contact the Ridewell Warranty Dept. at 417.833.4565 - Ext. 135, for complete warranty information.