



# PRIMARY TRAILER AXLE-APPLICATIONS AND PARTS GUIDE

## General Information

Suspension/Base Axle Identification	2
165— Base-Axle Part Number – Page Locator	3
164— Dressed-Axle Part Number Configurations	4
Wheel-End Equipment – Component Descriptions	5
Axle Beam Rating	6
Axle Track Dimensions	
Single-Wheel; Dual-Wheel	7
Wide-Base Wheel Configuration	8

## Service Parts – Drum Brake Axle

### 16.5” x 7.0” Brake Size

Long Cam – Without Cam Enclosure	9
Long Cam – With Cam Enclosure	10
Short Cam – With Cam Enclosure	11
Brake Chamber/Slack Adjuster	12
Hub and Drum	13

### 12.25” x 7.5” Brake Size

Long Cam – Without Cam Enclosure	14
----------------------------------	----

<b>Brake Chamber Mounting Pattern; Cam Rotation</b>	15
---	----

<b>Brake Shoes/Dust Shield/Anti-Lock Brake System (ABS)</b>	16
---	----

## Common Axle/Wheel-End Components

Wheel Bearing/Wheel Seal	17
Spindle Nut/Wheel Nut	18
Hubcap	19
Wheel Bearing Adjustment Procedure	20

## Service Parts – Air Disc Brake (ADB) Axle

22.5” Wheel Size – Wabco Caliper (Discontinued)	21
22.5” Wheel Size – Wabco; Haldex; Bendix Caliper	22
Hub and Rotor; Wheel-End Components	23
19.5” Wheel Size – Wabco Caliper	24
Hub and Rotor; Wheel-End Components	25
17.5” Wheel Size – Wabco Caliper	26
Caliper Parts Kit - Wabco	27
Caliper Parts Kit – Bendix; Haldex	28
Wheel Rotation (Disc Brake Axles)	29

## Maintenance

Torque Specifications – Axle/Wheel-End Components	30
Preventive Maintenance/Available Lubricants	31
Disc Brake Chamber Port Orientation	32
Cam Enclosure Replacement Procedure	33
Automatic Tire Inflation System (ATIS) Axle Preparation	35

<b>Warranty</b>	36
-----------------	----



WWW.RIDEWELLCORP.COM

### Serial Identification Tags

Ridewell suspension systems and Ridewell-branded axles are identified by the Suspension Model and Axle-Body Identification Tags.

### Axle-Body Identification Tag

The **Base-Axle Part Number (165-)** and the **Serial Number** of the axle tube are listed on the Axle-Body Identification Tag of Ridewell-branded round axles (Figure 1).

The **Base-Axle Part Number** applies to 5-inch “Standard” or 5 3/4-inch “Large Diameter Axle (LDA)” round axles manufactured in various axle-wall thicknesses and widths.

Parallel or tapered axle spindles; various disc or drum brake systems; and, other wheel-end equipment components are installed onto the Axle Body to create the **Ridewell Dressed-Axle Configuration** (Glossary on pgs 4-5).

### Suspension Identification Tag

A **(606-) Installation/Assembly Number** is listed as the **Part Number** when additional system components are factory installed onto the suspension model (Figure 2).

The **Suspension Number** and **Serial Number** on the Suspension Identification Tag refer to the suspension model and date of manufacture of an individual suspension system.

Please refer to the suspension number/part number and serial number on the Suspension Identification Tag when contacting Ridewell for customer service, replacement parts and warranty information.

### Notes and Cautions

All work should be completed by a properly trained technician using the proper/special tools and safe work procedures.

This guidebook uses two types of service notes to provide safety guidelines, prevent equipment damage and make sure that the axles/components operate correctly. The service notes are defined as:

“NOTE”: Provides additional instructions or procedures to complete tasks and make sure that the axle/components function properly.

**CAUTION** Indicates a hazardous situation or unsafe practice that, if not avoided, could result in equipment damage and serious injury.

 <b>RIDEWELL SUSPENSIONS</b>			
MODEL:		PART NO.	
SERIAL NO.		CAPACITY	TON

**Figure 1.**  
The **Base-Axle Part Number (165-)** and the **Serial Number** assigned to the axle tube are listed on the Axle-Body ID Tag.

 <b>RIDEWELL SUSPENSIONS</b> The Engineered Suspension Company	
PART NO:	
SUSP. NO:	
SERIAL NO:	
<p><b>GROSS AXLE WEIGHT RATING CERTIFICATION IS PER THE FINAL STAGE MANUFACTURER OR ALTERER.</b></p> <p><b>THIS PRODUCT MAY BE COVERED UNDER ONE OR MORE PATENTS, ADDITIONAL PATENTS MAY BE PENDING.</b></p> <p><b>www.ridewellcorp.com</b> <b>(800) 641-4122</b></p>	

**Figure 2.**  
The **Suspension Model (Suspension Number)** and **date of manufacture (Serial Number)** are listed on the Suspension Identification Tag.

**165— Base-Axle Part Number – Page Location**

The Serial Identification Tag attached to the axle-tube refers to the 165– Base-Axle Part Number (Figure 1; Page 2). Look for the **Base-Axle Part Number** in the chart below, then go to the listed page number(s) to find the Part Number for the Brake and other Wheel-End Components installed.

Contact Ridewell Customer Service if you have a 165- Base-Axle number not listed in the chart.

Part Number	Page	Part Number	Page	Part Number	Page	Part Number	Page
1650035	9	1650112	9	1650213	21	1650347	11
1650036	9	1650114	9	1650214	9	1650348	22-23
1650053	9	1650119	14	1650215	10	1650351	22-23
1650054	9	1650120	9	1650216-Δ	9	1650352	10
1650056	10	1650123	9	1650217-Δ	10	1650353	10
1650057	9	1650127	9	1650218-Δ	10	1650358	9
1650058	10	1650128	9	1650219	10	1650359	22-23
1650058D	11	1650131	9	1650222	21	1650360	22-23
1650059	9	1650134	10	1650227	14	1650362	22-23
1650061	9	1650136	10	1650228	21	1650364	9
1650062	9	1650140	9	1650229	21	1650365	10
1650063	9	1650141	10	1650234	21	1650366	10
1650064	9	1650144-Δ	10	1650235	21	1650367	10
1650069-Δ	9	1650146	9	1650236	21	1650368	10
1650070	9	1650148-Δ	9	1650237	21	1650369	10
1650071	10	1650149	9	1650239	9	1650370	10
1650072	9	1650150	9	1650240	22-23	1650371	10
1650074	9	1650151	9	1650241	22-23	1650372	10
1650075	14	1650155	14	1650251	11	1650373	10
1650076	14	1650160	10	1650251D	11	1650377	11
1650077	14	1650166	10	1650254	22-23	1650378	11
1650085	9	1650168	21	1650258	22-23	1650380	22-23
1650087	9	1650169	10	1650259	22-23	1650381	11
1650088	9	1650175	21	1650260	22-23	1650388	9
1650089	14	1650176	21	1650264-Δ	9	1650395	21
1650090	9	1650177	21	1650265	24-25	1650396	21
1650091	9	1650178	9	1650266	24-25	1650397	21
1650092	9	1650179	9	1650268	14	1650398	21
1650093	9	1650180	9	1650270D	11	1650400	22-23
1650094	9	1650181	9	1650271D	11	1650401	9
1650096-Δ	9	1650182	10	1650289	26	1650402	22-23
1650097-Δ	9	1650185-Δ	9	1650290	26	1650415	11
1650098	10	1650186	14	1650294	24-25	1650418	22-23
1650099	10	1650187	21	1650296D	11	1650428	11
1650100	9	1650188	9	1650297D	11	1650435	22-23
1650101	10	1650192-Δ	9	1650299	11	1650436	14
1650102	10	1650193	21	1650300	22-23	1650437	14
1650103-Δ	9	1650196-Δ	9	1650306	24-25	1650438	24-25
1650104-Δ	9	1650201-Δ	9	1650307	26	1650442	24-25
1650105-Δ	9	1650202	14	1650312	22-23		
1650106-Δ	9	1650205	11	1650325	9		
1650107-Δ	9	1650205D	11	1650326D	11		
1650108-Δ	9	1650206	11	1650335	11		
1650109	9	1650206D	11	1650341	22-23		
1650110	9	1650207	11	1650342	9		
1650111	9	1650207D	11	1650343	9		

Δ - Custom cam length needed. Contact Ridewell Customer Service.

### Track (Axle Track)

The distance between the centerline of two wheels mounted on each end of the axle. The theoretical centerline of a dual steel-wheel configuration sets the axle track specification.

### Camber (Optional)

Axle camber is the inward or outward angle of mounted tires. Positive camber means the top of the tires are farther apart than the bottom. Axles are cambered so that there is a bow in the axle. Weight is put on the axle to bring the wheel camber to zero. NOTE: All cambered axles should be installed with the center-bow up.

### ABS Prep

Denotes how the wheel-end components are prepared to install the Anti-Lock Braking System (ABS).

- Wheel hub is prepared without installed tone ring.
- Hub is prepped with installed tone ring
- Both tone ring and ABS sensor are installed.

### Spindle Type/Wall Thickness

The axle spindle supports wheel-end components. The Parallel Spindle extends out parallel to the axle body while the Tapered Spindle is smaller than the axle body at the axle end (Figure 4).

Wall (thickness) affects the axle load capacity - a thicker wall has a higher capacity.

### Brake Rating

The maximum stopping power of the drum or disc brake. Brake rating is dependent on the drum/disc brake type and size, type of brake pad/shoe lining, brake input power, the brake's structural rating and the tire static load radius.

The brake input power for cam/disc brakes includes air chamber size and slack adjuster length.

**CAUTION** Brake Rating must not be over- or under-sized. Confirm the suspension application brake rating with Ridewell Customer Service.

## 164— Dressed-Axle Part Number Definition - 16.5" x 7.0" Brake Size (pgs 9-13)

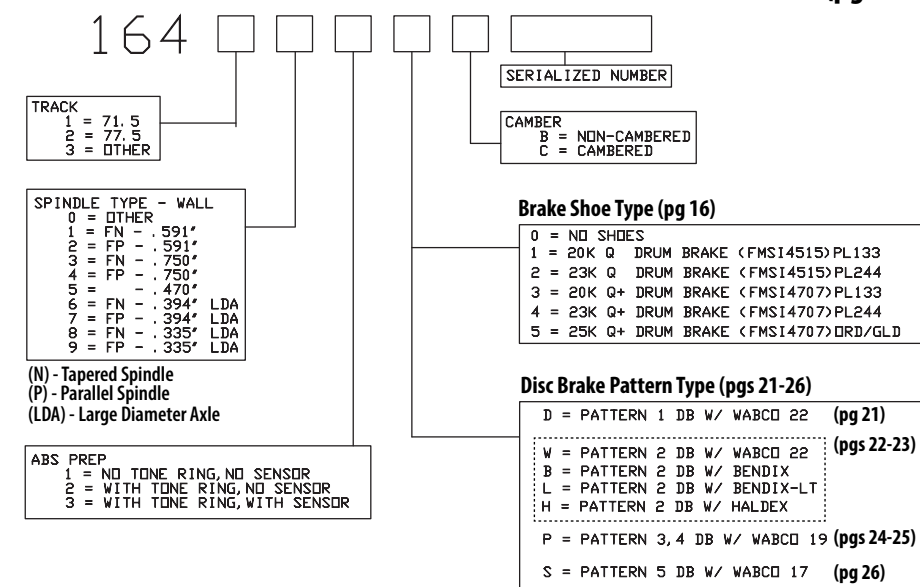

## 164— Dressed-Axle Part Number Definition - 12.25" x 7.5" Brake Size (pg 14)

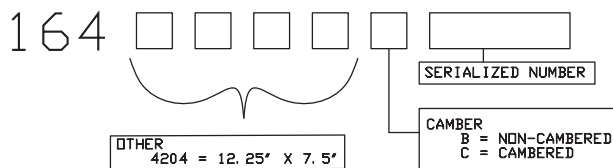
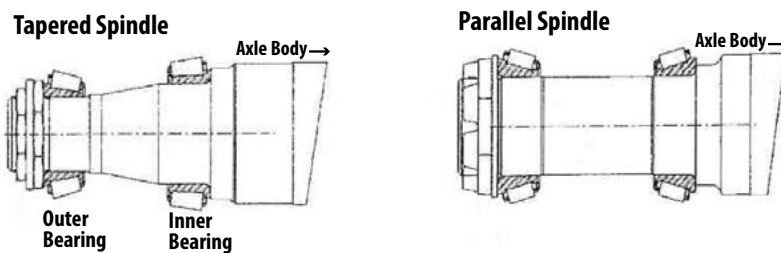
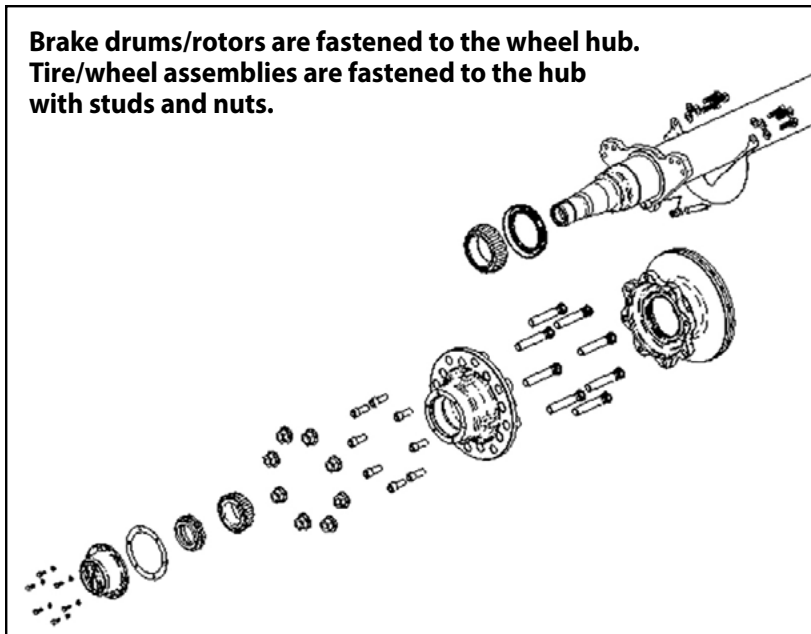

Figure 3.

The 11-digit 164- Dressed-Axle Part Number describes a 5-inch Standard Axle or a 5 3/4-inch Large Diameter Axle (LDA) configured with either a drum or disc brake assembly and other wheel-end equipment.

Figure 4.





**Figure 5.**  
**Wheel-End Equipment:**  
Rotating components on the axle end such as the wheel hub; wheel bearings; the hub seal; the hubcap; and, related equipment such as tire inflation systems are listed as wheel-end equipment.

### Hub Seal

A seal installed into the inboard side of the wheel hub to retain grease or oil and prevent external contamination from entering the interior hub cavity.

### Hubcap Gasket/Seal

A thin, flat seal or O-ring installed between the hubcap and the outboard face of the hub that prevents lubricant from leaking out of the hub and contaminants from entering the hub.

### Dust Shield

A thin sheet of metal bolted in place behind the rotor to protect from rocks, grit, and other debris found on the road. There are two types - rotor shields and brake-pad shields.

### ABS (Anti-Lock Braking System)

ABS system components include a toothed wheel (tone ring) mounted on the hub of each monitored wheel; an electronic sensor that has one end against the tooth wheel to monitor and transmit wheel speed; and, a sensor clip that holds the sensor in place.

### ABS Tone Ring (Exciter ring)

A notched ring (80-100 equally spaced slots) attached to a wheel hub or behind a brake rotor that is read by an ABS speed sensor to determine the speed of an individual wheel.

### Hub-Piloted Mounting

A wheel mounting system in which a boss on the hub is used to locate the center hole of a hub-piloted wheel. Flanged nuts are used to attach wheel to the flat face of the wheel disc.

### Stud-Piloted Mounting

A wheel mounting system in which location and fastening of the wheel are both accomplished by nuts which fit corresponding studs at each wheel bolt hole.

**AXLE BEAM RATING – 5" STANDARD AXLE;  
5 3/4" LARGE DIAMETER AXLE (LDA)**

**Standard Trailer Dimensions**

Trailer suspensions fit up onto standard I-beam trailer frames at the beam centers that correspond to standard axle track widths. Installation at wider beam centers will reduce the suspension clearances. Installation at narrower beam centers will de-rate the axle beam capacity.

NOTE: For other, non-standard beam centers, frames, frame centers, axle track widths and wheel-end equipment, the suspension installer is responsible for verifying clearances, axle capacity, proper fit-up, and any additional required suspension support structure.

**Gross Axle Weight Rating (GAWR)**

is a term used to specify the maximum load-carrying capacity of a single axle assembly.

The GAWR is determined by the component - the axle body, the suspension, brakes, hubs, bearings, wheels and tires - with the lowest rated capacity.

Vehicle manufacturers should follow the instructions supplied by other component manufacturers to determine the ratings for components not produced by Ridewell to determine the correct Gross Axle Weight Rating (GAWR).

This ensures the vehicle manufacturer complies with the appropriate Federal regulations.

Standard Configurations	Trailer Width	Axle Track	Frame Center	Beam Center	Air Spring Center
<b>Dual Wheel</b>	96"	71.5"	38"	35"	31"
	102"	77.5"	44"	41"	37"
<b>Wide-Base Wheel-Zero Offset</b>	102"	83.5"	50"	47"	43"

5-inch Axle (Standard)			Tube Wall	
Track Width (Inches)	Beam Centers (Inches)	Moment Arm (Inches)	0.591"	0.75"
			Axle Beam CAP GAWR (lbs)	Axle Beam CAP GAWR (lbs)
71.5"	38	16.75	23,000	25,000
	37	17.25	23,000	25,000
	36	17.75	23,000	25,000
	35	18.25	23,000	25,000
	34	18.75	22,387	24,333
	33	19.25	21,805	23,701
	32	19.75	21,253	23,101
	31	20.25	20,728	22,531
	30	20.75	20,229	21,988
	29	21.25	19,753	21,471
77.5"	44	16.75	23,000	25,000
	43	17.25	23,000	25,000
	42	17.75	23,000	25,000
	41	18.25	23,000	25,000
	40	18.75	22,387	24,333
	39	19.25	21,805	23,701
	38	19.75	21,253	23,101
	37	20.25	20,728	22,531
	36	20.75	20,229	21,988
	35	21.25	19,753	21,471
5.75-inch Axle Large Diameter Axle (LDA)			Tube Wall	
Track Width (Inches)	Beam Centers (Inches)	Moment Arm (Inches)	0.335" (On-Hwy Use Only)	0.394"
			Axle Beam CAP GAWR (lbs)	Axle Beam CAP GAWR (lbs)
71.5"	38	16.75	23,000	25,000
	37	17.25	23,000	25,000
	36	17.75	23,000	25,000
	35	18.25	23,000	25,000
	34	18.75	22,387	24,333
	33	19.25	21,805	23,701
	32	19.75	21,253	23,101
	31	20.25	20,728	22,531
	30	20.75	20,229	21,988
	29	21.25	19,753	21,471
77.5"	44	16.75	23,000	25,000
	43	17.25	23,000	25,000
	42	17.75	23,000	25,000
	41	18.25	23,000	25,000
	40	18.75	22,387	24,333
	39	19.25	21,805	23,701
	38	19.75	21,253	23,101
	37	20.25	20,728	22,531
	36	20.75	20,229	21,988
	35	21.25	19,753	21,471

### Dual Wheel Configuration

- (S) - Wheel Spacing
- (O) - Wheel Offset
- (W) - Tire Width
- (T) - Axle Track
- (TT) - Tire Track
- (TOD) - Tire Overall Diameter
- (ITW) - Inside Tire Width
- (OTW) - Outside Tire Width
- (SLR) - Static Load Radius

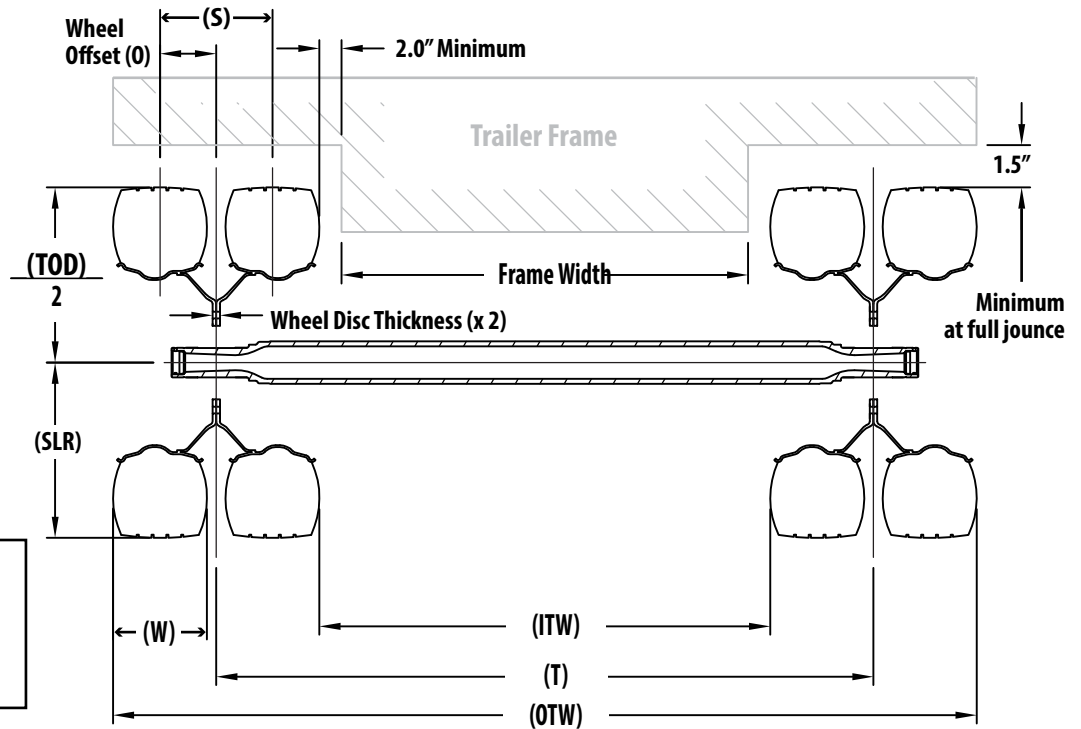

#### Dual Wheel Calculations

$$(S) = 2 \times O$$

$$(OTW) = T + S + W$$

$$(ITW) = T - S - W$$

### Single Wheel (Outset) Configuration

#### Axle and Bearing Rating:

Tapered (FN) spindles are not approved for use with 2-inch outset wheels. Parallel (FP) spindles are recommended for outset applications.

Outset wheels used in a single-tire configuration can reduce the axle beam rating and bearing life.

Using inset wheels in a single-tire configuration will not affect axle beam rating, but can reduce the bearing life.

Using outset wheels in a single-tire configuration moves the load point away from the center of the axle, increases the bending load in the axle, and reduces the axle beam rating and bearing life.

Contact the Ridewell Engineering Dept. to determine the rating for an axle that uses inset or outset wheels in a single-tire configuration.

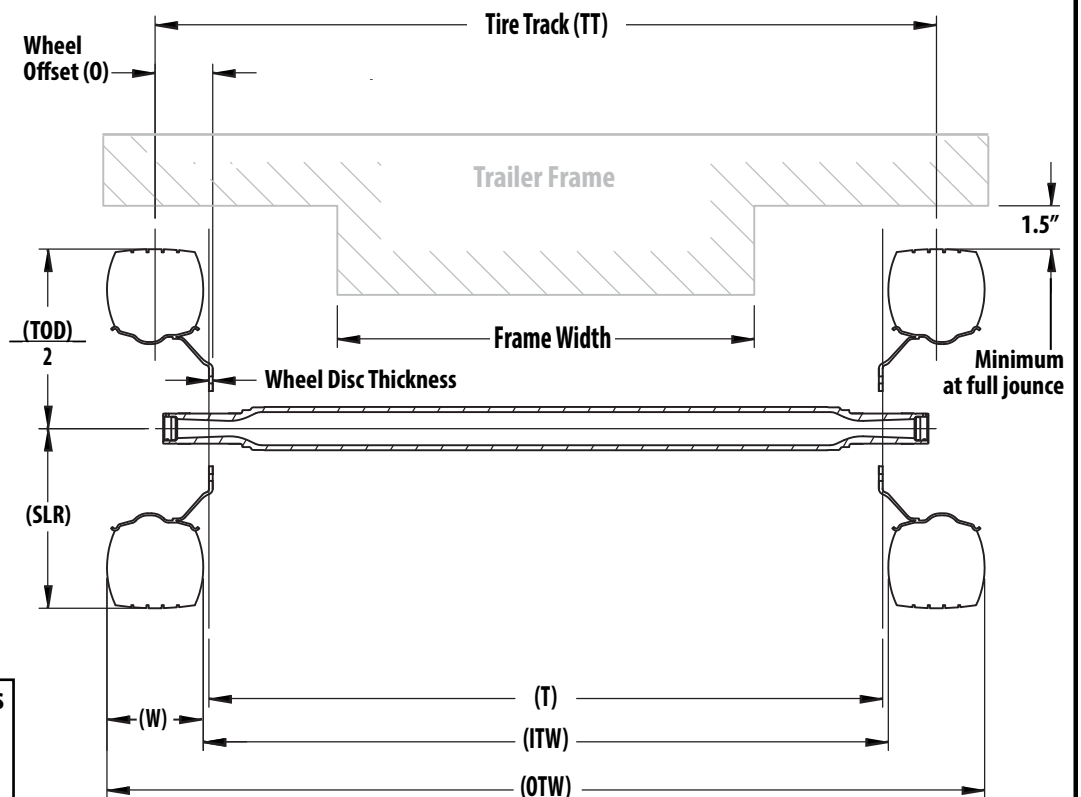

#### Single Wheel Calculations

$$(TT) = T + (2 \times O) - 7/8$$

$$(OTW) = TT + W$$

$$(ITW) = TT - W$$

### Wide-Base Wheel Configuration

(T) - Axle Track (S) - Wheel Spacing (TOD) - Tire Overall Diameter (WOS) - Wheel Outset  
 (TT) - Tire Track (O) - Wheel Offset (ITW) - Inside Tire Width (WIS) - Wheel Inset  
 (W) - Tire Width (OTW) - Outside Tire Width (SLR) - Static Load Radius

Std Config. Wide-Base Wheel- Zero Offset	Trailer Width 102"	Axle Track 83.5"	Frame Ctr 50"	Beam Ctr 47"	A/SpG Ctr 43"
--	-----------------------	---------------------	------------------	-----------------	------------------

**Inset Wheel Calculations**

$$(TT) = T - (2 \times WIS) - 7/8$$

$$(OTW) = TT + W$$

$$(ITW) = TT - W$$

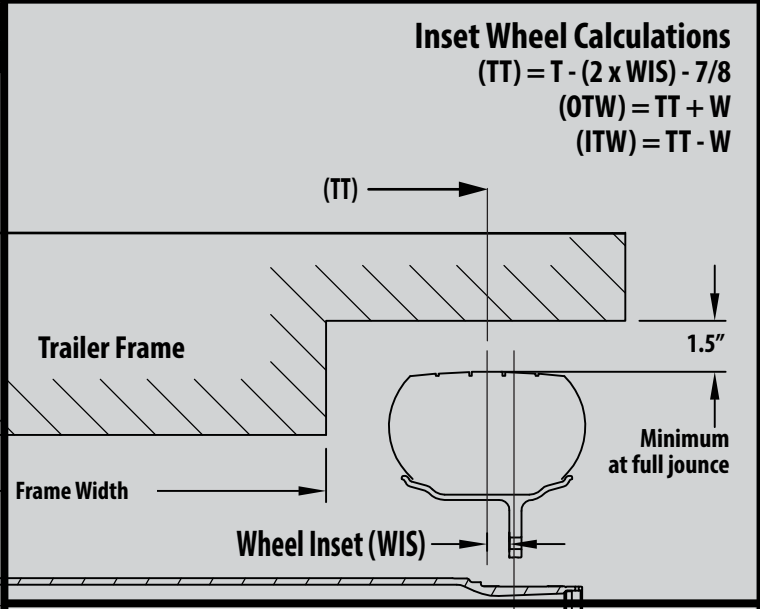
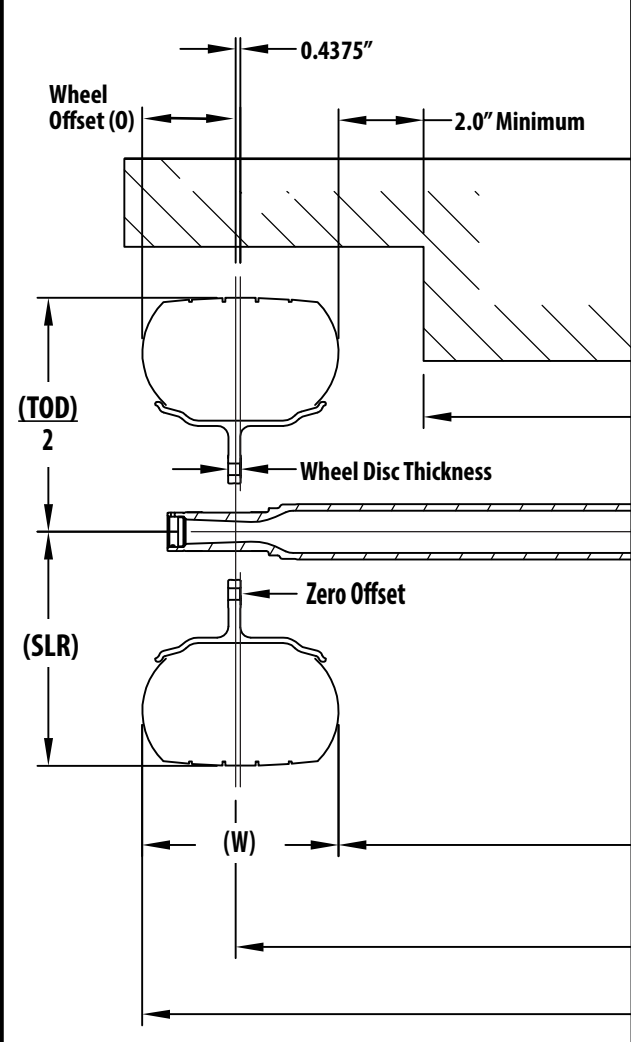

**Zero Offset Wheel Calculations**

$$(O) = W/2$$

$$(TT) = T - 7/8$$

$$(OTW) = TT + W$$

$$(ITW) = TT - W$$

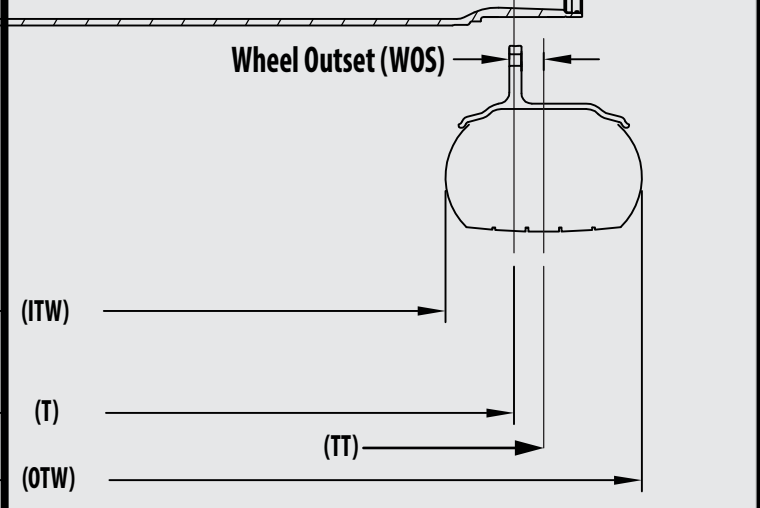

**Outset Wheel Calculations**

$$(TT) = T + (2 \times WOS) - 7/8$$

$$(OTW) = TT + W$$

$$(ITW) = TT - W$$

**Axle and Bearing Rating:**  
 Tapered (FN) spindles are not approved for use with 2-inch outset wide-base wheels. Parallel (FP) spindles are recommended for outset applications.  
 Offset wheels used in a single-tire configuration can reduce the axle beam rating and bearing life.  
 Using inset wheels in a single-tire configuration will not affect axle beam rating, but can reduce the bearing life.

Using outset wheels in a single-tire configuration moves the load point away from the center of the axle, increases the bending load in the axle, and reduces the axle beam rating and bearing life.  
 Contact the Ridewell Engineering Dept. to determine the rating for an axle that uses inset or outset wheels in a single-tire configuration.



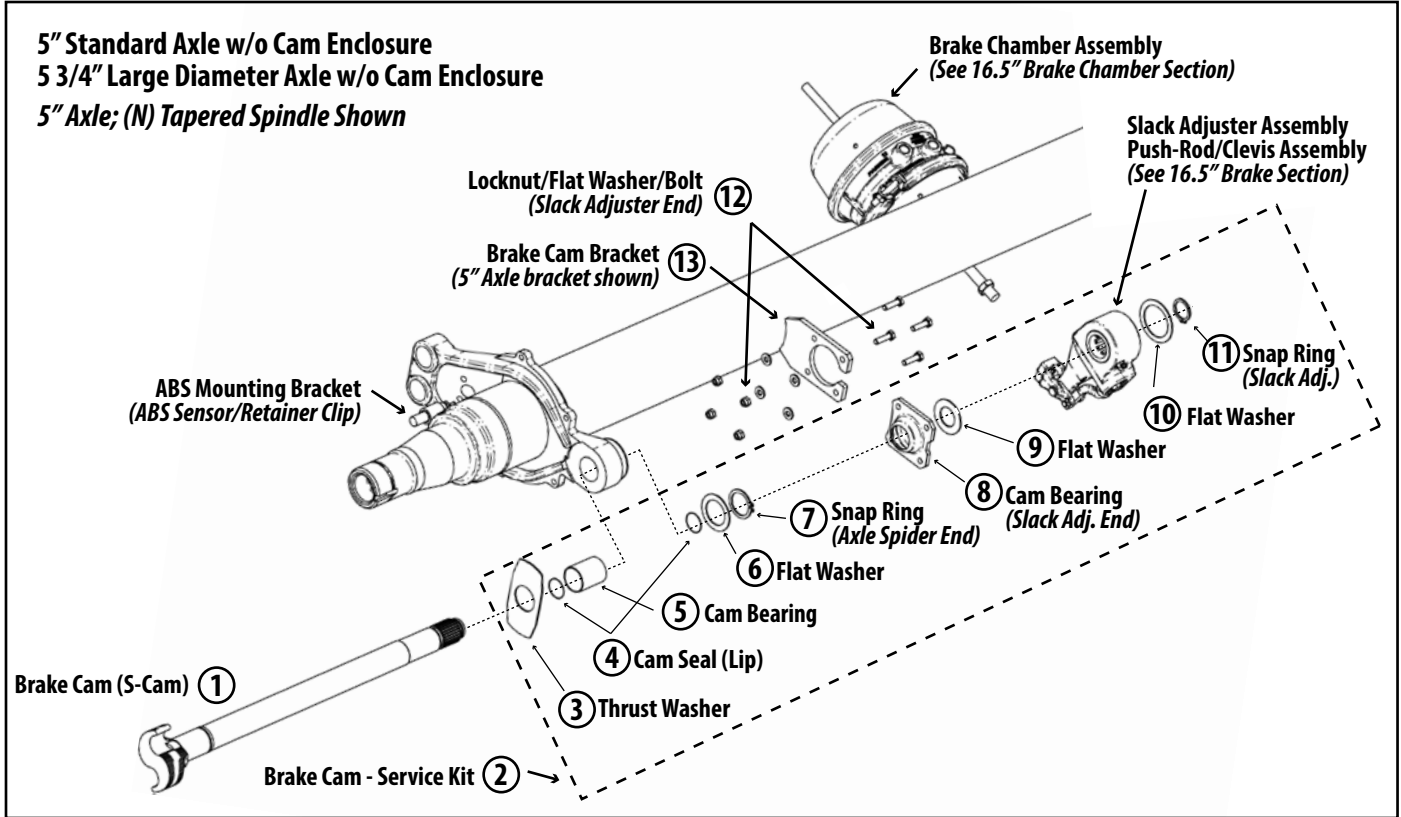

Diagram No.	QTY Per Axle	Part Number	Item Description	
<b>1</b>	<b>1</b>	1667591B104	Left-Hand S-Cam (613 mm)	
	<b>1</b>	1667591B204	Right-Hand S-Cam (613 mm)	
	<b>Page three lists 165-Δ part number (Base axle that requires custom cam-length)</b>			
	<b>1</b>	165xxxx-Δ	Left-Hand S-Cam (Contact Ridewell for cam-length)	
	<b>1</b>	165xxxx-Δ	Right-Hand S-Cam (Contact Ridewell for cam-length)	
<b>2</b>	<b>1</b>	<b>1667591B054 – Cam Service Kit (613mm Cam)</b>		
<b>Included in Service Kit</b>	<b>3</b>	<b>2</b>	1667591B043	Thrust Washer (Axle Spider End)
	<b>4</b>	<b>4</b>	1667591B038	Lip Seal (Axle Spider End)
	<b>5</b>	<b>2</b>	1667591B039	Cam Bearing (Axle Spider End)
	<b>6</b>	<b>2</b>	1667591B014	Flat Washer (Axle Spider End)
	<b>7</b>	<b>2</b>	1667591B015	Snap Ring (Axle Spider End)
	<b>8</b>	<b>2</b>	1667591B045	Cam Bearing (Slack Adjuster End)
	<b>9</b>	<b>20</b>	1667591B044	Spacer Washer (Slack Adjuster End)
	<b>10</b>	<b>2</b>	1667591B016	Flat Washer (Slack Adjuster)
<b>11</b>	<b>2</b>	1667591B017	Snap Ring (Slack Adjuster)	
<b>12</b>	<b>8</b>	1150063	Locknut - M8 (Slack Adjuster End)	
	<b>8</b>	1140081	Bolt (HHCS) – M8 x 30mm (Slack Adjuster End)	
	<b>8</b>	1160031	Flat Washer (Slack Adjuster End)	
<b>13</b>	<b>2</b>	7720039	Brake Cam Bracket	

**5" Standard Axle w/ Cam Enclosure**  
**5 3/4" Large Diameter Axle w/ Cam Enclosure**  
**(N) Tapered Spindle Shown**

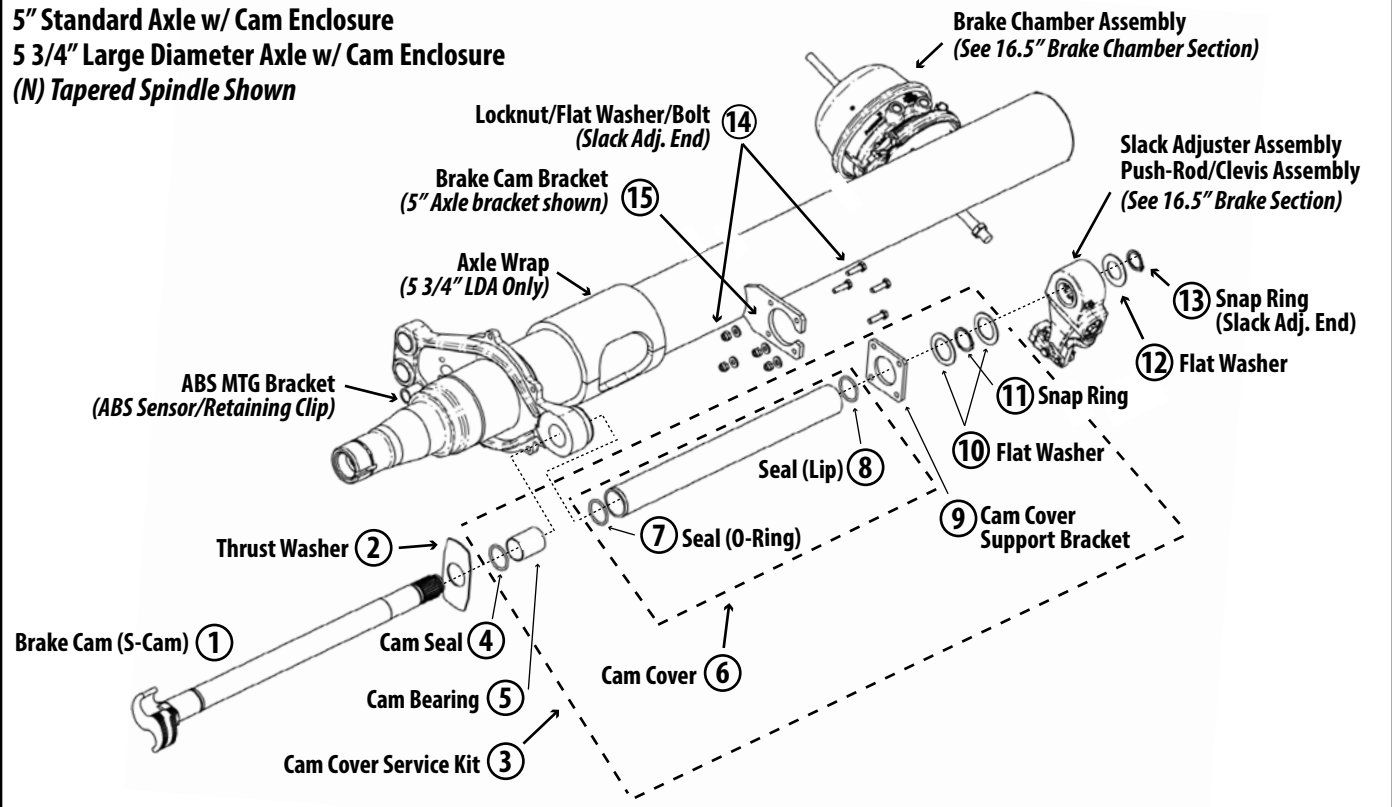

Diagram No.	QTY PER AXLE	PART NUMBER	ITEM DESCRIPTION	
<b>1</b>	<b>1</b>	1667591B106	Left-Hand S-Cam (613 mm)	
	<b>1</b>	1667591B206	Right-Hand S-Cam (613 mm)	
	<b>Page three lists 165-Δ part number (Base axle that requires custom cam-length)</b>			
	<b>1</b>	165xxxx-Δ	Left-Hand S-Cam (Contact Ridewell for cam-length)	
	<b>1</b>	165xxxx-Δ	Right-Hand S-Cam (Contact Ridewell for cam-length)	
<b>2</b>	<b>2</b>	1667591B043	Thrust Washer (S-Cam)	
<b>3</b>	<b>2</b>	<b>1660306 Cam Cover Service Kit (613mm Cam)</b>		
<b>Included in Service Kit</b>	<b>4</b>	<b>1</b>	1667591B038	S-Cam - Seal (Axle Spider End)
	<b>5</b>	<b>1</b>	1667591B039	S-Cam - Bearing (Axle Spider End)
	<b>6</b>	<b>1</b>	1667591B036	Cam Cover Assembly (536 mm); bushings included
	<b>7</b>	<b>1</b>	1660633	Seal (O-Ring) - Cam Cover (Axle Spider End)
	<b>8</b>	<b>1</b>	1660634	Seal (Lip) - Cam Cover (Slack Adjuster End)
	<b>9</b>	<b>1</b>	1667591B037	Support Bracket (2" Universal) - Cam Cover
	<b>10</b>	<b>10</b>	1667591B044	S-Cam - Spacer Washer (Slack Adjuster End)
<b>11</b>	<b>1</b>	1667591B009	S-Cam - Snap Ring (Slack Adjuster End)	
<b>12</b>	<b>2</b>	1667591B016	S-Cam - Spacer Washer (Slack Adjuster)	
<b>13</b>	<b>2</b>	1667591B017	S-Cam Snap Ring (Slack Adjuster)	
<b>14</b>	<b>8</b>	1150063	Locknut - M8 (Slack Adjuster End)	
	<b>8</b>	1140081	Bolt (HHCS) - M8 x 30mm (Slack Adjuster End)	
	<b>8</b>	1160031	Flat Washer (Slack Adjuster End)	
<b>15</b>	<b>2</b>	7720039	Cam Bracket - 5" Standard Axle	
	<b>2</b>	7004538	Cam Bracket - 5 3/4" LDA	

**5 3/4" Large Diameter Axle (LDA)  
with Short Cam Enclosure  
(N) Tapered Spindle Shown**

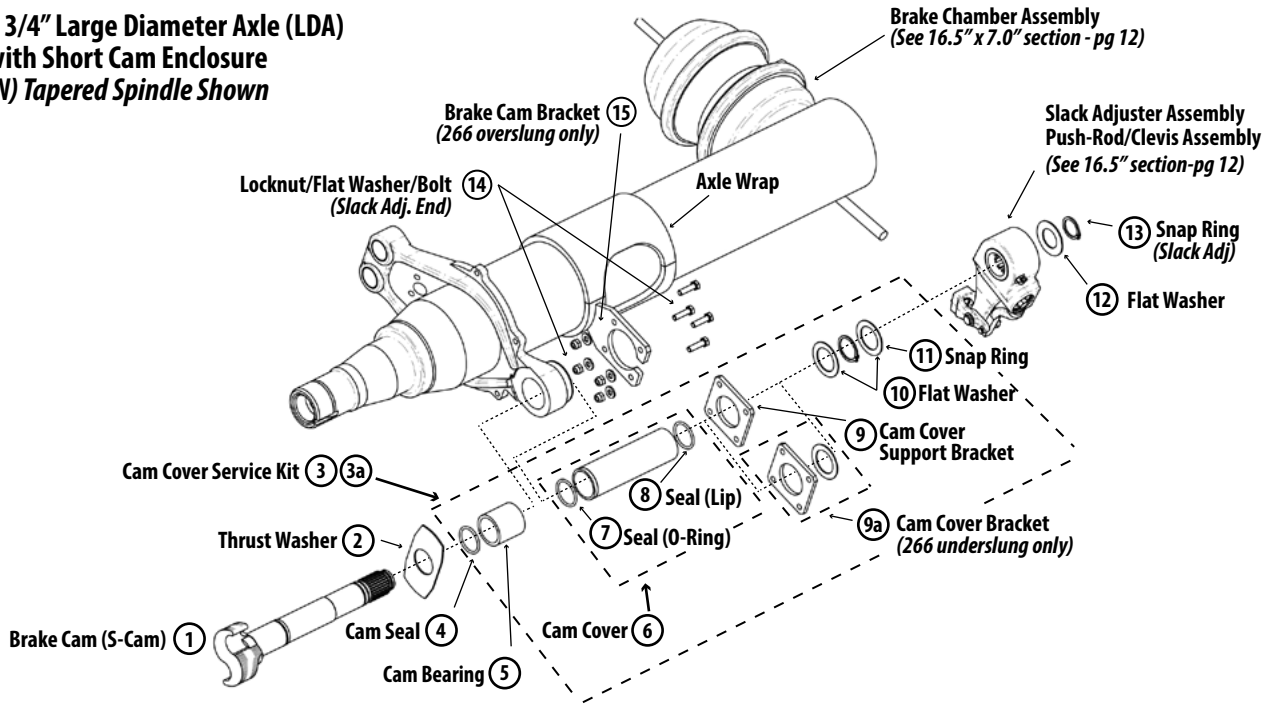

Diagram No.	QTY/AXLE	PART NUMBER	ITEM DESCRIPTION	
1	1	1667591B108	Left-Hand Short S-Cam (283 mm)	
	1	1667591B208	Right-Hand Short S-Cam (283 mm)	
2	2	1667591B043	Thrust Washer (S-Cam)	
3	2	<b>1660387 – 283mm Cam Cover Service Kit for RAR 266 Overslung Suspensions</b>		
Included in Service Kit	4	1667591B038	S-Cam - Seal (Axle Spider End)	
	5	1667591B039	S-Cam - Bearing (Axle Spider End)	
	6	1667591B049	Short Cam-Cover Assembly (169.5 mm); Bushings included	
	7	1660633	Seal (O-Ring) - Cam Cover (Axle Spider End)	
	8	1660634	Seal (Lip) - Cam Cover (Slack Adjuster End)	
	9	1667591B037	Support Bracket (2" Universal) - Cam Cover	
	10	10	1667591B044	S-Cam - Spacer Washer (Slack Adjuster End)
11	1	1667591B009	S-Cam - Snap Ring (Slack Adjuster End)	
3a	2	<b>6040225 – 283mm Cam Cover Service Kit for RAR 266 Underslung (Low-Mount) Suspensions</b>		
Included in Service Kit	4	1667591B038	S-Cam - Seal (Axle Spider End)	
	5	1667591B039	S-Cam - Bearing (Axle Spider End)	
	6	1667591B049	Short Cam-Cover Assembly (169.5 mm); Bushings included	
	7	1660633	Seal (O-Ring) - Cam Cover (Axle Spider End)	
	8	1660634	Seal (Lip) - Cam Cover (Slack Adjuster End)	
	9a	1	7002913	Cam Cover Bolt Flange - 266 Low-Mount
	9a	1	7002914	Weld Flange Cam Cover - 266 Low-Mount
	10	10	1667591B044	S-Cam - Spacer Washer (Slack Adjuster End)
11	1	1667591B009	S-Cam - Snap Ring (Slack Adjuster End)	
12	2	1667591B016	S-Cam - Spacer Washer (Slack Adjuster)	
13	2	1667591B017	S-Cam Snap Ring (Slack Adjuster)	
14	8	1150063	Locknut - M8 (Slack Adjuster End)	
	8	1140081	Bolt (HHCS) – M8 x 30mm (Slack Adjuster End)	
	8	1160031	Flat Washer (Slack Adjuster End)	
15	2	7002997	LDA Brake Cam Bracket (B13-6301) – RAR 266 overslung only	

<b>Brake Chamber – (16.5" x 7.0" Brake Size)</b>					
<b>Part Number</b>	<b>Brake Chamber Type</b>	<b>Stroke Length</b>	<b>Push-Rod Length (in)</b>	<b>Manufacturer</b>	<b>Notes</b>
<b>5" Standard Axle (Straight)</b>					
1660191	Type 20	2.50	5.750	DiPro	
1660421	Type 30	2.50	5.700	Haldex	
1660176	Type 30	2.50	5.750	DiPro	
1660259	Type 30	2.50	5.750	FUWA	
1664702B303	30/30	2.50	5.625	MGM	
1660174	30/30	2.50	5.750	DiPro	
1660285	30/30	2.50	5.750	FUWA	
1660381	30/30	2.50	5.750	TSE	OMNI
1660550	30/30	2.50	5.750	Wabco	TRISTOP IBV
1660250	30/30	2.50	5.700	Haldex	Gold Seal (GS)
1660357	30/30	3.00	5.750	TSE	OMNI
1660382	30/30	3.00	5.750	TSE	
1660345	30/30	3.00	5.625	MGM	
1660342	30/30	3.00	5.625	MGM	
<b>5 3/4" Large Diameter Axle – Overslung (RAR-266 Suspension)</b>					
1667591B047	30/30	2.50	9.750	FUWA	
1660598	Type 30	2.50	9.900	Haldex	
1667591B053	30/30	2.50	9.800	Haldex	Gold Seal (GS)
1667591B055	30/30	2.50	9.800	Haldex	Life Seal (LS)
1660551	30/30	2.50	9.800	Wabco	TRISTOP IBV
1660605	30/30	3.00	9.750	TSE	OMNI
<b>5 3/4" Large Diameter Axle – Underslung (RAR-266 Suspension)</b>					
1667591B057	30/30	2.50	5.750	FUWA	Long Cam
<b>Long Push-Rod – Cut push-rod to required length</b>					
1660283	30/30	2.50	12.0	DiPro	Ships uncaged

<b>Slack Adjuster (Brake Size - 16.5" x 7.0")</b>				
<b>Part Number</b>	<b>Slack Size</b>	<b>Spline</b>	<b>Manufacturer</b>	<b>Clevis/Anchor Pin</b>
1660501	5.5"	28	Gunite	Requires Clevis-1660290
1664206B038	5.5"	28	Haldex	Requires Clevis-1667591B001; Anchor Pin-1667511B006
1660179	5.5"	28	Bendix	Includes Clevis
1660173	6"	28	Bendix	Includes Clevis
1660289	6"	28	Gunite	Requires Clevis-1660290
1664206B011	6"	28	Haldex	Requires Clevis-1667591B001; Anchor Pin-1667511B006
1667591B048	6"	28	FUWA	Includes Clevis

**16.5"x7.0" Brake Size—Hub and Drum Components (Hub-Piloted) - 10-Stud x 11.25" Bolt Circle**

Spindle	Hub Mtrl	Drum Mtrl	Stud Lgth	Tone Ring	Side Fill Port	Hub Part Number	Drum Part Number	Hub MFG	Hub & Drum Part Number	Wheel Stud Part Number
P	Cast Iron-Easy Roll	Lightweight	Long	Yes	No	1660389	1667511B027	WEMC		02-00045
	Cast Iron	Lightweight	Long	No	Yes	1660234	1667511B027	Gunite		W1402
	Cast Iron	Lightweight	Long	Yes	Yes	1660235	1667511B027	Gunite		W1402
	Cast Iron	Lightweight	Long	Yes	Yes	1660344	1667511B027	KIC		1660083
	Cast Iron	Cast Iron	Long	No	Yes		1667591B031	RW Std	1660060	1660083
	Cast Iron	Cast Iron	Short	Yes	Yes		1667591B031	RW Std	1660069	1660056
	Cast Iron	Cast Iron	Short	No	Yes		1667591B031	RW Std	1660157	1660056
	Cast Iron	Cast Iron	Long	Yes	Yes	1660344	1667591B031	RW Std	1660186	1660083
	ALUM	Lightweight	Long	Yes	Yes	1660196	1667511B027	ConMet		102292
	ALUM	Cast Iron	Long	Yes	Yes	1660196	1667591B031	ConMet		102292
	ALUM	Cast Iron	Long	Yes	Yes	1660196	1667591B034	ConMet		102292
	ALUM	Lightweight	Long	No	Yes	1660266	1667511B027	ConMet		102291
	ALUM	Lightweight	Long	Yes	Yes	1660277	1667511B027	ConMet		102291
	ALUM	Cast Iron	Long	Yes	Yes	1660277	1667591B031	ConMet		102291
	ADI	Lightweight	Short	No	No	1660187	1667511B027	Wemc		02-00110
	ADI	Lightweight	Long	Yes	Yes	1660213	1667511B027	WEMC		1660610
	ADI	Cast Iron	Long	Yes	Yes	1660213	1667591B031	WEMC		1660610
	ADI	Lightweight	Long	No	Yes	1660251	1667511B027	WEMC		1660610
ADI	Lightweight	Short	Yes	No	1660340	1667511B027	WEMC		02-00110	
N	Cast Iron-Fat Boy		Long	Yes	No	1667511B034		WEMC		02-00045
	Cast Iron	Lightweight	Long	Yes	Yes	1667511B035	1667511B027	KIC		1660083
	Cast Iron	Cast Iron	Long	No	Yes		1667591B031	RW Std	1667511B000	1660083
	Cast Iron	Cast Iron	Short	No	Yes		1667591B031	RW Std	1667511B004	1660056
	Cast Iron	Cast Iron	Short	Yes	Yes		1667591B031	RW Std	1667511B015	1660056
	Cast Iron	Cast Iron	Long	Yes	Yes	1667511B035	1667591B031	RW Std	1667511B016	1660083
	ALUM	Lightweight	Long	Yes	Yes	1660249	1667511B027	ConMet		102190
	ALUM	X30	Long	Yes	Yes	1667511B019	1667511B013	ConMet		102189
	ALUM	Lightweight	Long	Yes	Yes	1667511B019	1667511B027	ConMet		102189
	ADI	Cast Iron	Long	Yes	Yes	1667511B026		WEMC		1660610
ADI	Lightweight	Long	Yes	Yes	1667511B026	1667511B027	WEMC		1660610	
<b>1660057</b>	Flanged Wheel Nut-M22x1.5x33 (1.30" x 1.22") - See Drum Brake/Wheel End Parts (pgs 16-18)									

**12.25" x 7.5" BRAKE SIZE**  
**LONG CAM – WITHOUT CAM ENCLOSURE**

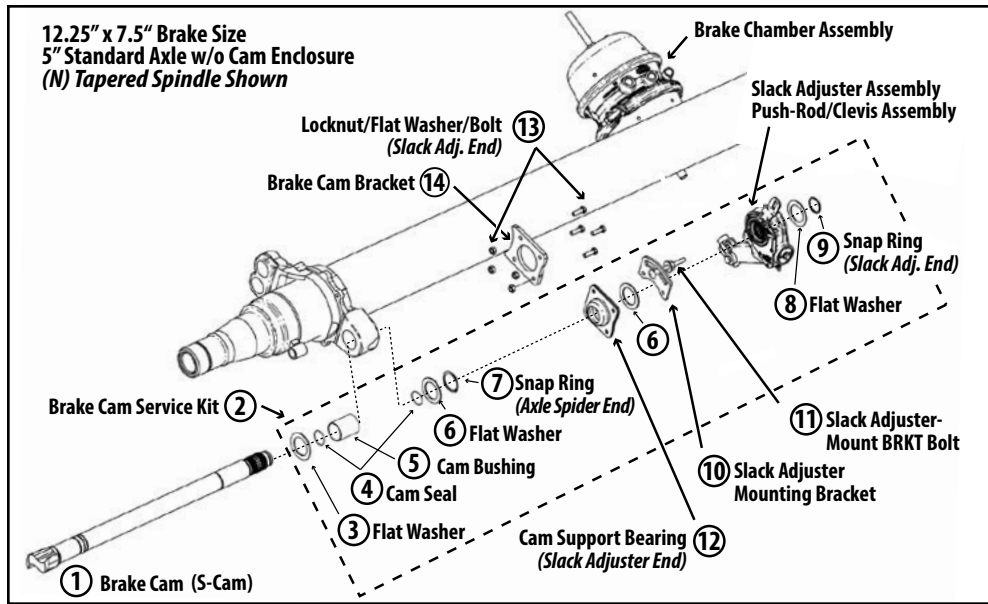
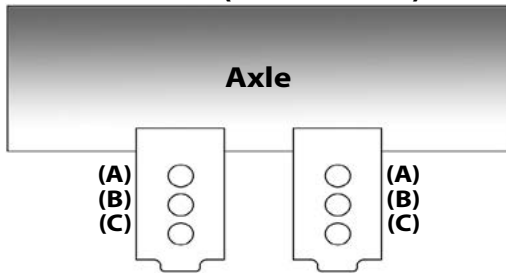

Diagram No.	QTY Per Axle	Part Number/Manufacturer Part Number	Item Description							
1	1	Meritor - R607253	Left-Hand S-Cam (594 mm)							
	1	Meritor - R607254	Right-Hand S-Cam (594 mm)							
2	1	<b>Meritor - R615020–Cam Service Kit (594mm Cam)</b>								
Included in Service Kit	3	Meritor-E-719	S-Cam Washer (Spider End)							
	4	Meritor-R627018	S-Cam Seal (Spider End)							
	5	Meritor-R657001	S-Cam Bushing (Spider End)							
	6	1667591B016	S-Cam Washer (Slack Adjuster End)							
	7	Meritor-1229-Z-1118	S-Cam Snap Ring (Spider End)							
	8	1667591B044	Spacer Washer (Slack Adjuster End)							
	9	1667591B017	Snap Ring (Slack Adjuster)							
10	2	1667591B056	Slack Adjuster Mounting Bracket							
11	2	1667511B006	Slack Adjuster Mounting Bracket Bolt (Flat)							
12		1667591B045	S-Cam Support Bearing (Slack Adjuster End)							
13	8	1150063	Locknut - M8 (Slack Adjuster End)							
		1140081	Bolt (HHCS) – M8 x 30mm (Slack Adjuster End)							
		1160031	Flat Washer (Slack Adjuster End)							
14	2	7720039	Brake Cam Bracket							
<b>Brake Chamber</b>		<b>Part Number</b>	<b>Stroke Length</b>	<b>Push-Rod Length</b>	<b>Manufacturer</b>					
Type 30		1664204B004	2.50"	4.25"	DiPro					
30/30		1664204B003	2.50"	4.25"	DiPro					
<b>Slack Adjuster</b>		<b>Part Number</b>	<b>Slack Size</b>	<b>Spine</b>	<b>Clevis Included/Added Kit</b>					
FUWA (MFG)		1664204B005	6"	28"	1667591B001 (Includes Anchor Pin)					
<b>Hub and Drum (Hub-Piloted – 8-Stud x 10.83" Bolt Circle)</b>										
<b>Spindle Type</b>	<b>Hub Material</b>	<b>Drum Material</b>	<b>Stud Length</b>	<b>Tone Ring</b>	<b>Side Fill Port</b>	<b>Hub Part Number</b>	<b>Drum Part Number</b>	<b>Manuf.</b>	<b>Hub &amp; Drum Part Number</b>	<b>Wheel Stud Part Number</b>
N	Cast Iron	Cast Iron	Short	Yes	Yes	Hub-0013FT	54244-01	KIC	1664204B001	1660056
	Cast Iron	Cast Iron	Short	No	Yes	Hub-0013F	54244-01	KIC	1664204B002	1660056
	Cast Iron	Cast Iron	Long	No	Yes	Hub-0013FL	54244-01	KIC	1664205B004	1660083
	Cast Iron	Cast Iron	Long	Yes	Yes	1664205B013	54244-01	KIC	1664205B005	1660083
<b>1660057</b> - Flanged Wheel Nut-M22x1.5x33 (1.30" x 1.22") — See Drum Brake/Wheel End Service Parts (pgs 16-18)										

**Five-Inch (Standard Axle)**



**Brake Chamber Mount Hole Patterns**

Brake Size	16.5 x 7.0"	12.25 x 7.5"
Hole-Code	Slack Adjuster Length	Slack Adjuster Length
A - A	5"	—
A - B	5.5"	5"
B - B	6"	5.5"
B - C	—	6"

**266 Large Diameter Axle (LDA)**

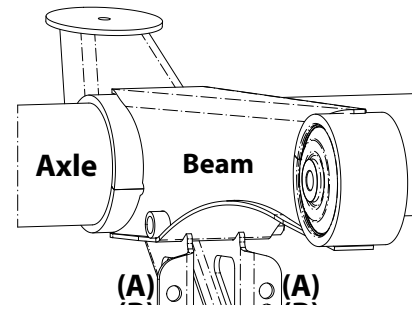

**Brake Chamber Mount Hole Patterns**

Brake Size	16.5" x 7.0"
Hole - Code	Slack Adjuster Length
A - A	—
A - B	5.5"
B - B	6"

← **Front of Vehicle** →

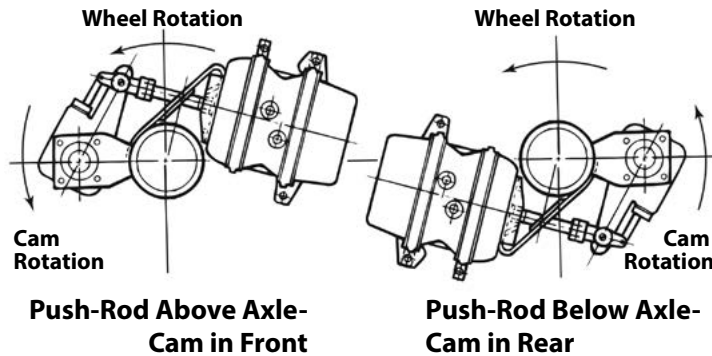

Install axle assembly so that, when the brakes are activated, the camshaft rotates in the same direction as the wheels when vehicle moves forward.

Opposite rotation of the camshafts can cause vibrations that damage components such as the air chambers and chamber brackets attached to axle.

There are two recommended configurations for axle installations:

- Cams front and air chamber push-rod above the axle.
- Cams rear and air chamber push-rod below the axle.

The decision on which axle assembly configuration to use is based on obtaining adequate clearance between the axle and other vehicle components, maximizing ground clearance, or locating components for maintenance access.

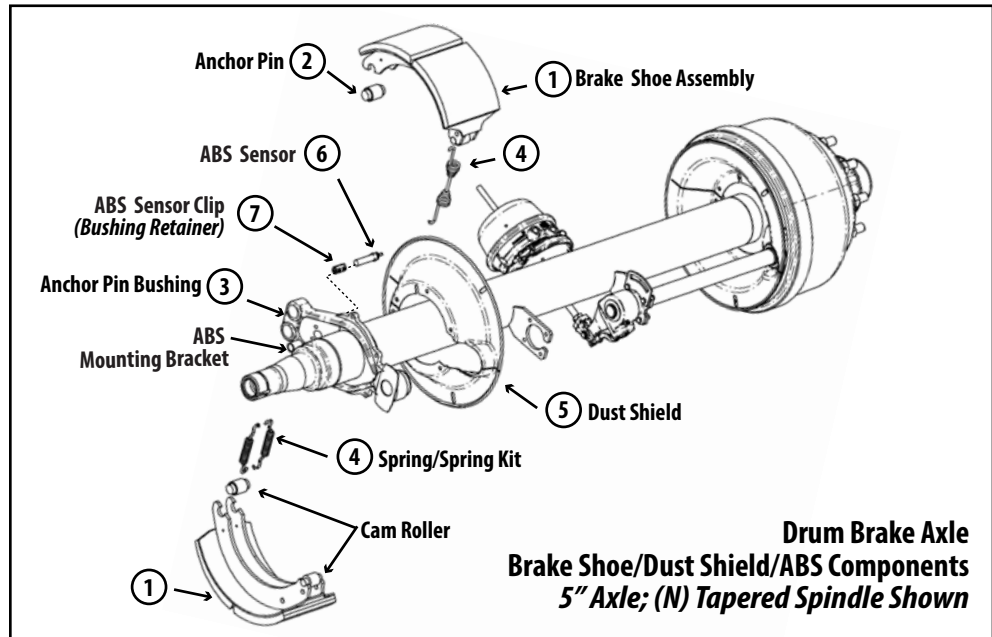

**Drum Brake Components – Service Parts**

DGMM No.	QTY Per Axle	Item Description	16.5" x 7.0" Brake Size 20K Brake Rating-PL133		16.5" x 7.0" Brake Size- 23K Brake Rating-PL244		12.25" x 7.5" Brake Size 20K Brake Rating-PL244	
			Q+	1667591B305 FMSI-4707	Q+	1667591B306 FMSI 4707	Q	1664204B006 FMSI 4692
1	4	Brake Shoe/Brake Lining ASY (includes brake cam roller and clip)	Q+	1667591B305 FMSI-4707	Q+	1667591B306 FMSI 4707	Q	1664204B006 FMSI 4692
2	4	Anchor Pin		1667591B010		1667591B010		1667591B010
3	4	Anchor Pin Bushing		Meritor 1225-B-496		Meritor 1225-B-496		Meritor 1225-B-496
4	4	Retainer Spring		1667591B012		1667591B012		1667591B012
	2	Return Spring		1667591B035		1667591B035		1664204B011
DGMM No.	QTY Per Axle	Item Description	Part Number					
5	2	16.5" x 7.0" Dust Shield (18.11"OD 2.83 DP)	1667511B005					
	6	Hex Washer Head Screw 5/16 - 18NC .5"LG	1137511B005					
5	2	12.25" x 7.5" Dust Shield (13.78"OD 2.38 DP)	1664204B008					
	4	Hex Washer Head Screw 5/16 - 18NC .5"LG	1137511B005					

**Anti-Lock Brake System (ABS) Components – Service Parts**

DGMM No.	QTY Per Axle	Manufacturer	MFR Part Number	Item Description (Lead Length)	Sensor Type	Part Number
6	2	Wabco	4410328080	Sensor (< 1 ft Lead)	90-Degree	1664702B001(Obsolete)
			4410323340	Sensor (3.28 ft Lead)	Straight	1664702B003(Obsolete)
7	2		8997598154	Sensor Clip (Bushing Retainer)	—	1664702B002
6	2	Bendix	K145016BX	Sensor (5.58 ft Lead)	Straight	1664702B010
			K144020BX	Sensor (5.58 ft Lead)	90-Degree	1664702B012
7	2		K152407	Sensor Clip (Bushing Retainer)	—	1664702B002
—	—		300259	Sensor Extension Cable (10-ft)	—	1420210



**Wheel-End Components**  
*Drum brake axle assembly shown*

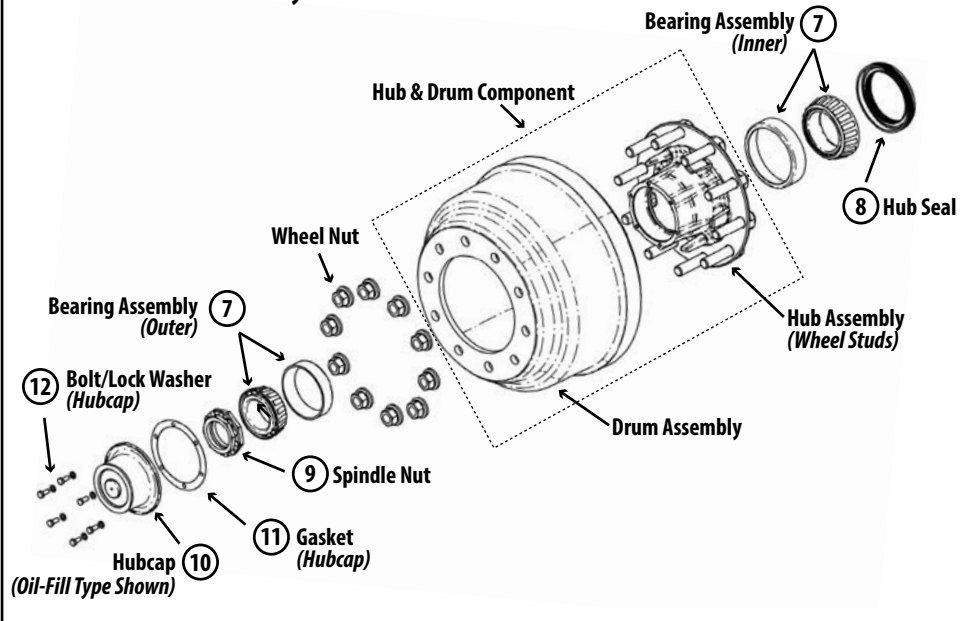

Wheel Bearing								
Diagram No.	Spindle	Part Number	Item Description	Cup/Cone	Location	Manufacturer	Industry Number	
7	N	1664206B008	Bearing Assembly	Cone	Inner	VNC	HM218248	
		1664206B009	Bearing Assembly		Outer	VNC	HM212049	
		1664206B041	Bearing Assembly		Inner	Hyatt	HM218248	
		1664206B042	Bearing Assembly		Outer	Hyatt	HM212049	
		1664206B028	Bearing Assembly		Inner	Stemco	KHM218248	
		1664206B027	Bearing Assembly		Outer	Stemco	KHM212049	
	P	N	1664206B032	Bearing Race	Cup	Inner	VNC	HM218210
			1664206B033	Bearing Race		Outer	VNC	HM212011
		P	1660048	Bearing Assembly	Cone	Inner/Outer	VNC	HM518445
			1660304	Bearing Assembly		Inner/Outer	Stemco	KHM518445
1660502	Bearing Assembly		Inner/Outer	Hyatt		HM518445		
		1660527	Bearing Assembly		Inner/Outer	Timken	HM518445	
		1660397	Bearing Race	Cup	Inner/Outer	VNC	HM518410	
Hub Seal								
Diagram No.	Spindle	Part Number	Item Description - Brand Name	Manufacturer	MFR Part Number			
8	N	1667537B004	Guardian HP	Stemco	307-0743			
		1664206B026	Discover		373-0243			
		1660458	Gold PTFE	National	M380025			
	P	1660276	Guardian HP	Stemco	307-0723			
		1660215	Discover		373-0223			
		1660494	Gold PTFE	National	M386590T			

**Wheel-End Components**  
*Drum brake axle assembly shown*

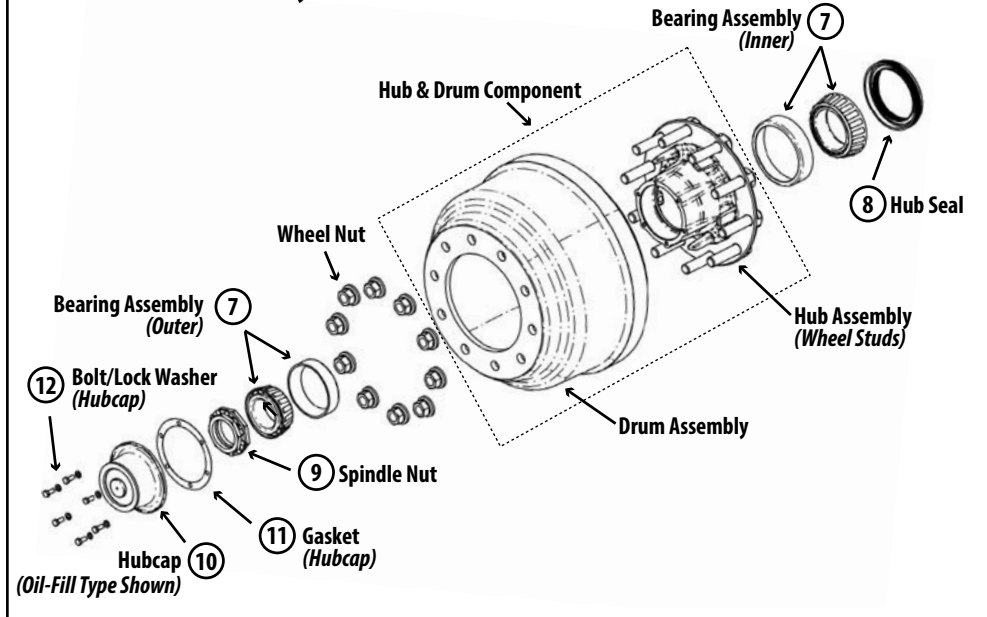

**Spindle Nut**

Diagram No.	Spindle Type	QTY/AXLE	PART NUMBER	ITEM DESCRIPTION
9	P	2	1660597 – Spindle Nut Kit	
		1	1660051	Castle Nut
		1	1660052	Washer
		1	1660373	Cotter pin
		1	1660366	Spindle Nut Kit (Meritor - 4 pcs w/ set screw)
		2	1660493	Spindle Nut (ConMet PreSet; PreSet Plus - #10080657)
	2	1660629	Spindle Nut (Stemco - Zip-Torq)	
	N	2	1664206B014 – Spindle Nut Kit	
		1	1664206B035	Inner spindle nut
		1	1664206B034	Lock Washer
1		1664206B036	Outer nut	
1	1664206B037	Tabbed Lock Washer		
2	1660453	Spindle Nut (ConMet PreSet; PreSet Plus - #10045896)		
2	1660630	Spindle Nut (Stemco - Zip-Torq)		

**Wheel Nut**

Diagram No.	Spindle Type	QTY/AXLE	PART NUMBER	ITEM DESCRIPTION
FLANGED			1660057	Flanged Wheel Nut – M22 x 1.5 x 33 (1.30" x 1.22")
			1660226	Flanged Wheel Nut – M18 x 1.5 (1.06" x 0.97")
BALL SEAT			1664203B003	Inner Wheel Nut #105988 3.06 – ALUM Wheel (3/4"-16NF; Inner RH)
			1664203B004	Inner Wheel Nut #105989 3.06 – ALUM Wheel (3/4"-16NF; Inner LH)
			1664203B009	Inner Wheel Nut #001-5549L 2.24 – Steel Wheel (3/4"-16NF; Inner LH)
			1664203B010	Inner Wheel Nut #001-5549R 2.24 – Steel Wheel (3/4"-16NF; Inner RH)
			1664203B007	Outer Wheel Nut #001-5552L (1 1/8"-16; Outer KIC™)
			1664203B008	Outer Wheel Nut #001-5552R (1 1/8"-16; Outer KIC™)

**Wheel-End Components**  
*Drum brake axle assembly shown*

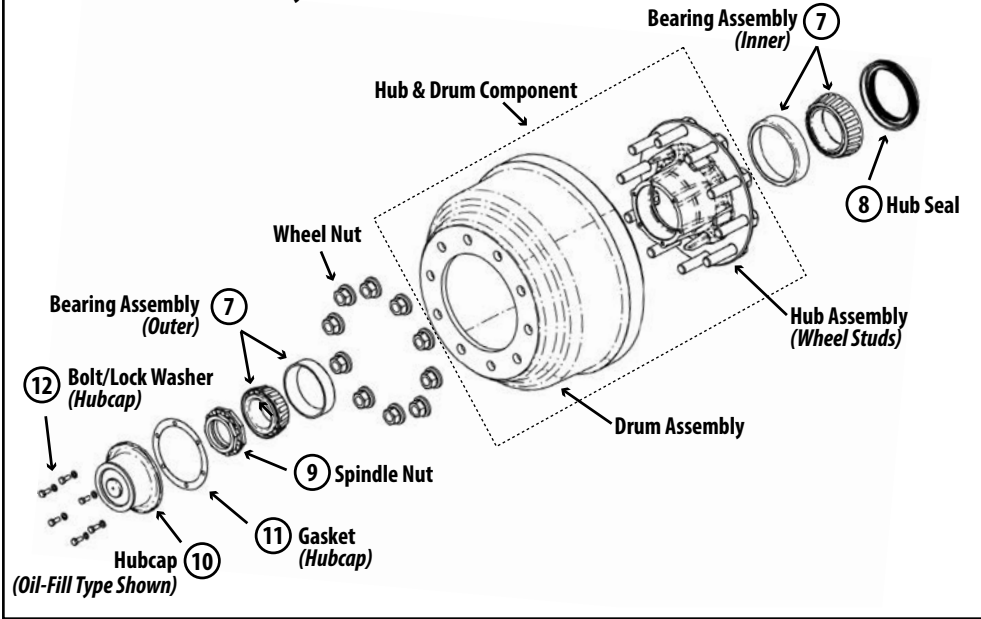

Hubcap									
Diagram No.	Spindle Type	QTY/AXLE	PART NUMBER	LUBRICATION TYPE	Auto Tire Inflation	Side-Fill Port	Vent-Type	Manuf.	Manuf. Part Number
10	N	2	1664206B006	Oil		Yes	Standard	Stemco	343-4009
			1664206B018	Oil		No	Standard		340-4009
			1660346	Oil		Yes	Sentinel		348-4009
			1664206B040	Oil		Yes	ESP Plug		353-4009
			1660128	Oil	P.S.I.	Yes			343-4370
			1664206B029	Hard/S-F Grease		No	Sentinel		349-4009
			1660155	Hard/S-F Grease		No	Duckbill		352-4009
			1660375	Hard/S-F Grease	P.S.I.	No			340-4370
11	N	2	1664206B007	Gasket			Stemco	330-3009	
10	P	2	1660054	Oil		Yes	Standard	Stemco	343-4195
			1660341	Oil		Yes	Sentinel		348-4195
			1660214	Oil	P.S.I.	Yes			343-4372
			1660305	Hard/S-F Grease		No	Sentinel		349-4195
			1660435	Hard/S-F Grease		No	Duckbill		352-4195
			1660238	Hard/S-F Grease	P.S.I.	No			343-4372
11	P	2	1660055	Gasket			Stemco	330-3118	
Diagram No.	Spindle Type	QTY/AXLE	PART NUMBER	ITEM DESCRIPTION					
12	—	12	1144206B105	Bolt (HHCS) 5/16"-18NC 3/4" LG					
	—	12	1164263B100	Lock Washer 5/16"					

## Wheel Bearing Adjustment Procedure

Refer to TMC's Recommended Practice 618 - "Wheel Bearing Adjustment Procedure." The procedure should obtain a verifiable wheel bearing end-play between 0.001" - 0.005" (0.025 mm to 0.13 mm). TMC's Wheel Bearing Adjustment Procedure is for manually adjusted wheel ends. The procedure is not applicable to preset or unitized wheel ends.

**CAUTION** For wheel bearing adjustments on manually adjusted wheel ends, the optimum condition for measuring end-play is with the tires/wheels and brake drum removed from the hub. Always support the vehicle with stands; do not work under a unit supported by only a jack. Block the wheels and make sure vehicle cannot roll before releasing the brakes.

*NOTE: Do not use an impact wrench to tighten or loosen spindle nuts during wheel bearing adjustment.*

### Double Adjusting Nut System (Figure 6)

1. Lubricate bearing with the same type of lubricant used in the hub assembly.
2. While rotating the wheel, torque adjusting nut (A) to 200 ft-lb (271 N·m).
3. Back off the adjusting nut (A) one full turn from the bearing.
4. While rotating the wheel, tighten adjusting nut to final torque – 50 ft-lb (68 N·m).
5. Back off the adjusting nut 1/4-to-1/3 turn. Install lock washer (B) using nearest hole.
6. Install outer jam-nut (C). Torque to 200-300 ft-lb (271-407 N·m).
7. Check end-play (0.001" to 0.005" [0.025 mm to 0.13 mm]).

Verify that the wheel rotates freely when adjustment is completed.

### Single Adjusting Nut System (Figure 7)

1. Lubricate bearing with the same type of lubricant used in the hub assembly.
2. Install lock washer (B).
3. While rotating the wheel, torque adjusting nut (A) to 200 ft-lb (271 N·m).
4. Back off the adjusting nut (A) one full turn from the bearing.
5. While rotating the wheel, tighten adjusting nut to final torque – 50 ft-lb (68 N·m).
6. Back off the adjusting nut 1/6-to-1/4 turn to the nearest locking hole.
7. Install cotter pin.
8. Check end-play (0.001" to 0.005" [0.025 mm to 0.13 mm]).

Verify the wheel rotates freely when adjustment is completed.

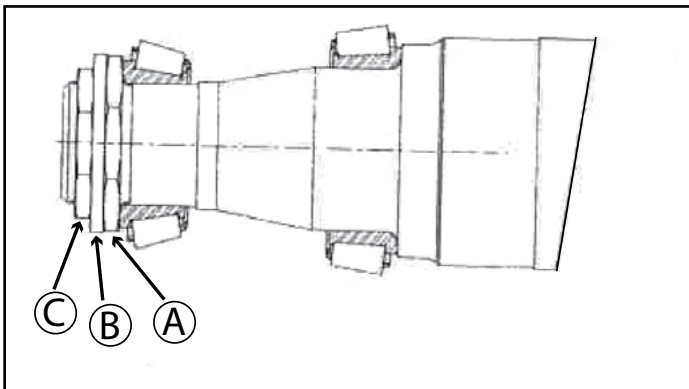

**Figure 6.**  
Double Adjusting Nut System

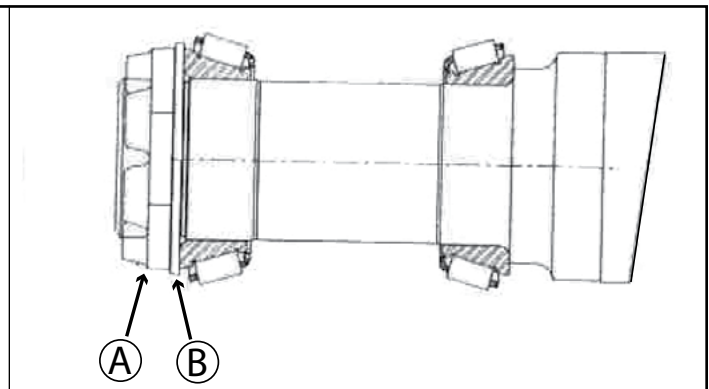

**Figure 7.**  
Single Adjusting Nut System

See 164– Dressed-Axle Part Number Definitions on page 4 for axle identification.

164xxxDxxxx–Wabco Caliper

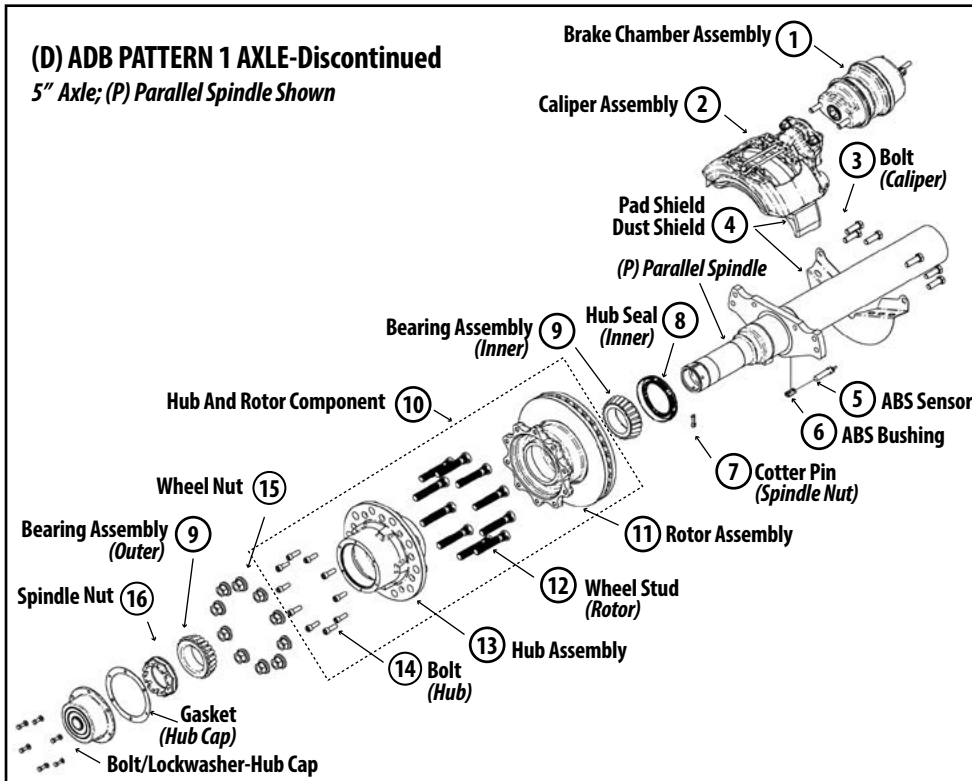

DIAG No.	QTY/Axle	Part Number	Item Description
1	1	1660351	SPG BRK CHMBR ASY (20/24), 45 Deg. (20K brake rating)
	1	1660352	SPG BRK CHMBR ASY (20/24), 135 Deg. (20K brake rating)
	1	1660203	SPG BRK CHMBR ASY (24/24), 45 Deg. (23K brake rating)
	1	1660204	SPG BRK CHMBR ASY (24/24), 135 Deg. (23K brake rating)
	1	1660433	Brake actuator, Service Only, Type 20, 45 Deg. (20K brake rating)
	1	1660434	Brake actuator, Service Only, Type 20, 135 Deg. (20K brake rating)
	1	1660205	Brake actuator, Service Only, Type 24, 45 Deg. (23K brake rating)
	1	1660206	Brake actuator, Service Only, Type 24, 135 Deg. (23K brake rating)
2	1	1660360	Caliper Assembly (Left-Hand)
	1	1660361	Caliper Assembly (Right-Hand)
	1	1660362	Pad Kit, PAN 22 (Not Shown)
3	10	1130045	Hex Head Cap Screw (HHCS) M16-1.5 x 55mm; GR 10.9
	2	1130046	Hex Head Shoulder Cap Screw (HHSCS) M16-1.5 x 55mm; GR 10.9
4	2	1660386	Dust Shield – Pattern 1 - PAN 22
5	2	1664702B010	ABS - Sensor (See page 16)
6	2	1664702B002	ABS - Bushing (See page 16)
7	2	1660373	Cotter Pin (Spindle Nut)
8	2	1660215	Hub Seal (Inner)
9	4	1660304	Bearing Cone - 3.5" ID (Inner/Outer)
10	2	1660359	Hub and Rotor Component (P) Spindle - PAN 22
11	2	1660363	Rotor, PAN 22
12	20	1660083	Wheel Stud - M22 x 1.5; 4.79" length
13	2	1660364	Hub Assembly - (P); 10-Stud (with cups and wheel nuts)
14	20	1130044	Rotor to Hub Fastener M16 - 2 x 35mm; GR 10.9
15	20	1660057	Wheel Nut
16	2	1660597	Spindle Nut (Castle Nut) Kit (See page 18)
—	2	1660xxx	Hubcap Options-Oil or Hard/Semi-Fluid Grease Lubrication (See page 19)
—	2	1660055	Hubcap Gasket (See page 19)

**22.5" WHEEL SIZE –  
WABCO; HALDEX; BENDIX CALIPER**

See 164– Dressed-Axle Part Number Definitions on page 4 for axle identification.

- 164xxxWxxxx–Wabco Caliper
- 164xxxBxxxx–Bendix Caliper
- 164xxxLxxxx–Bendix Light-Duty Caliper
- 164xxxHxxxx–Haldex Caliper

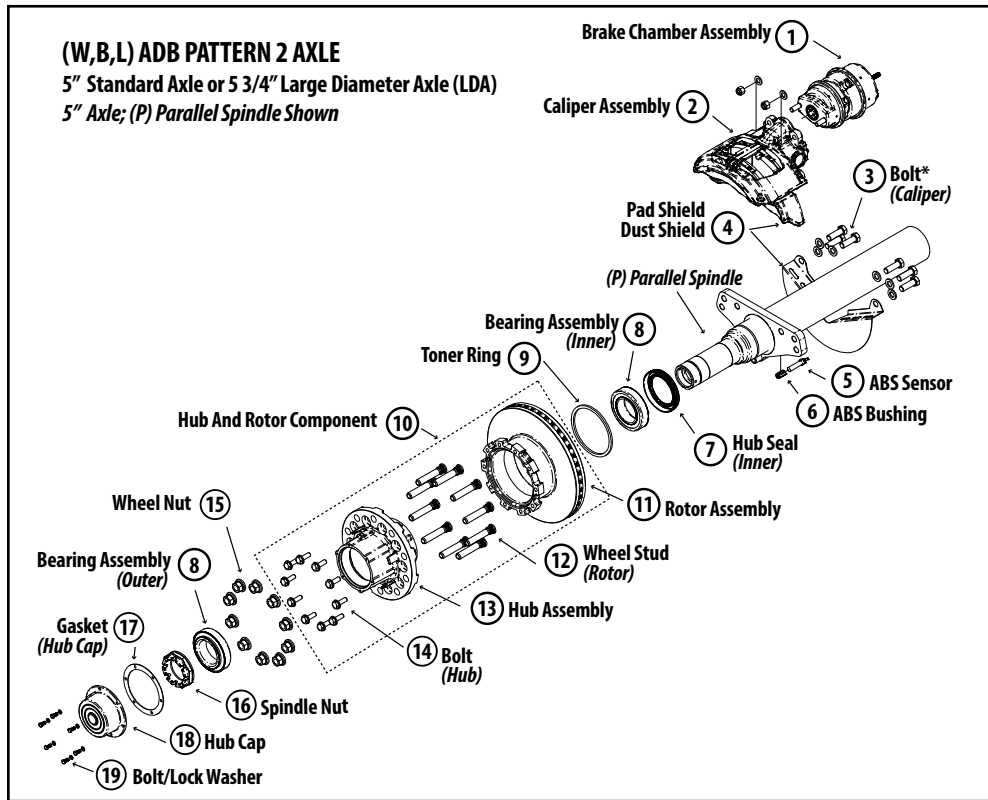

DIAG No.	QTY/Axle	Part No.	Item Description
1	1	1660428	SPG BRK CHMBR ASY - Bendix/Haldex (18/24) 45 Deg. (20K/23K brake rating)
	1	1660429	SPG BRK CHMBR ASY - Bendix/Haldex (18/24) 135 Deg. (20K/23K brake rating)
	1	1660351	SPG BRK CHMBR ASY - Wabco (20/24) 45 Deg. (20K brake rating)
	1	1660352	SPG BRK CHMBR ASY - Wabco (20/24) 135 Deg. (20K brake rating)
	1	1660203	SPG BRK CHMBR ASY - Wabco (24/24) 45 Deg. (23K brake rating)
	1	1660204	SPG BRK CHMBR ASY - Wabco (24/24) 135 Deg. (23K brake rating)
	1	1660456	Brake actuator, Service Only, Bendix/Haldex (Type 18) 40 Deg. (20K/23K brake rating)
	1	1660457	Brake actuator, Srvc Only, Bendix/Haldex (Type 18) 140 Deg. (20K/23K brake rating)
	1	1660433	Brake actuator, Srvc Only, Wabco (Type 20) 45 Deg. (20K brake rating)
	1	1660434	Brake actuator, Srvc Only, Wabco (Type 20) 135 Deg. (20K brake rating)
	1	1660205	Brake actuator, Srvc Only, Wabco (Type 24) 45 Deg. (20K brake rating)
	1	1660206	Brake actuator, Srvc Only, Wabco (Type 24) 135 Deg. (20K brake rating)
2	1	1660401	Bendix ADB22X, Caliper Assembly (Right-Hand)
	1	1660402	Bendix ADB22X, Caliper Assembly (Left-Hand)
	1	1660528	Bendix ADB22X-LT, Caliper Assembly (Left-Hand)
	1	1660529	Bendix ADB22X-LT, Caliper Assembly (Right-Hand)
	1	1660515	Haldex DBT22LT, Caliper Assembly (Left-Hand)
	1	1660516	Haldex DBT22LT, Caliper Assembly (Right-Hand)
	1	1660403	Wabco, PAN 22 Caliper Assembly (Left-Hand)
	1	1660404	Wabco, PAN 22 Caliper Assembly (Right-Hand)
2	1	1660362	Pad Kit, Wabco PAN 22 (Not Shown)
	1	1660546	Pad Kit, Bendix ADB22X ; ADB22X-LT (Not Shown)
	1	1660686	Pad Kit, Haldex DBT22LT (Not Shown)
3	12	1140087	Bolt (HHCS) M20-2.5x60mm; GR 10.9 (Obsolete)
	12	1160025	Flat Washer (M20) (Obsolete)
	12	1130093	Flanged Bolt (HHCS) M20-2.5x55mm GR10.9 (Flanged bolt replaces bolt/lock washer)

Continued on next page

DIAG.No.	QTY/Axle	Part No.	Item Description
4	2	1660422	Dust Shield
	2	1660479	Pad Shield - Bendix ( <i>Caliper Only</i> )
5	2	1664702B010	ABS - Sensor ( <i>See page 16</i> )
6	2	1664702B002	ABS - Bushing ( <i>See page 16</i> )
7	2	1660494	Hub Seal (Inner) - National Gold PTFE
	2	1660276	Hub Seal (Inner) - STEMCO Guardian® HP
8	4	1660304	Bearing Cone - 3.5" ID (Inner/Outer)
9	2	1660441	Tone Ring ( <i>ConMet® Hub 1660405/1660356-before 04/01/2018</i> )
	2	1660604	Tone Ring ( <i>ConMet Hub 1660405/1660356-04/01/2018-03/01/2019</i> )
	2	1660615	Tone Ring ( <i>ConMet Hub 1660405/1660356-after 03/01/2019</i> )
10	2	1660400	Gunite® - Hub, Rotor, and Tone Ring Assembly, Cast/Cast ( <i>Discontinued</i> )
11	2	1660439	Gunite - Rotor Only w/ Integral Tone Ring
	20	W1402	Wheel Stud - Gunite
	2	Not Available	Gunite - Hub Only
	20	1140092	Bolt - Rotor to Hub; Gunite (5/8" - 11)
		1160029	Washer - Rotor to Hub; Gunite (5/8")
10	2	1660603	KIC - Hub and Rotor w/ Integral Tone Ring ( <i>Discontinued</i> )
11	2	1660614	KIC - Rotor Only w/ Integral Tone Ring ( <i>Discontinued</i> )
	2	1660439	Gunite - Rotor Only w/ Integral Tone Ring (Requires P/N 1140092 and P/N 1160029)
	20	1660083	Wheel Stud - KIC
	2	Not Available	KIC - Hub Only
	20	Not Available	Bolt - Rotor to Hub; KIC (M16 x 2 x 45 HHCS)
		Not Available	Washer - Rotor to Hub; KIC (M16; Hardened)
10	2	1660676	Accuride - Hub, Rotor, and Tone Ring Assembly ( <i>Discontinued</i> )
11	2	1660439	Gunite - Rotor Only w/ Integral Tone Ring
	20	1660083	Wheel Stud - KIC
	2	Not Available	KIC - Hub Only
	20	1140092	Bolt - Rotor to Hub; Gunite (5/8" - 11)
		1160029	Washer - Rotor to Hub; Gunite (5/8")
10	2	1660405	ConMet - Hub, Rotor, and Tone Ring Assembly, AL/Cast
	2	1660356	ConMet PreSet® - Hub, Rotor, and Tone Ring Assembly, AL/Cast ( <i>Discontinued</i> )
	2	1660642	ConMet PreSet Plus® - Hub, Rotor, and Tone Ring Assembly, AL/Cast
11	2	1660440	ConMet - Rotor Assembly w/ Integral Tone Ring
	20	102291	Wheel Stud - ConMet (M22 x 1.5 mm x 4.97 Lg [3.44" Standout])
	2	Not Available	ConMet - Hub Only
	20	10009971	Flanged Nut (5/8"-18) Rotor to Hub - ConMet
10	2	1660552	Walther EMC - Hub, Rotor, and Tone Ring Assembly, ADI/Cast
11	2	1660554	Walther EMC - Rotor Kit w/ Integral Tone Ring
	20	1660553	Wheel Stud - Walther EMC
	2	1660555	Walther EMC - Hub only
10	2	1660685	Webb - Hub, Rotor, and Tone Ring Assembly
11	2	1660693	Webb - Rotor Only
	20	1660694	Wheel Stud - Webb
	2	1660695	Webb - Hub only
	20	1130094	Bolts/Washers Rotor to Hub - Webb (5/8" x 11)
15	20	1660057	Wheel Nut
16	2	1660597	Spindle Nut (Castle Nut) Kit
17	2	1660055	Gasket (Hub Cap)
18	2	166xxxx	Hub Cap <i>Options-Oil or Hard/Semi-Fluid Grease Lubrication (See page 19)</i>
19	12	1144206B105	HHCS 5/16" - 18NC 3/4" length
	12	1164263B100	Lock Washer 5/16"

**19.5" WHEEL SIZE –  
WABCO CALIPER**

See 164– Dressed-Axle Part Number Definitions on page 4 for axle identification.

164xxxPxxxx–Wabco Caliper

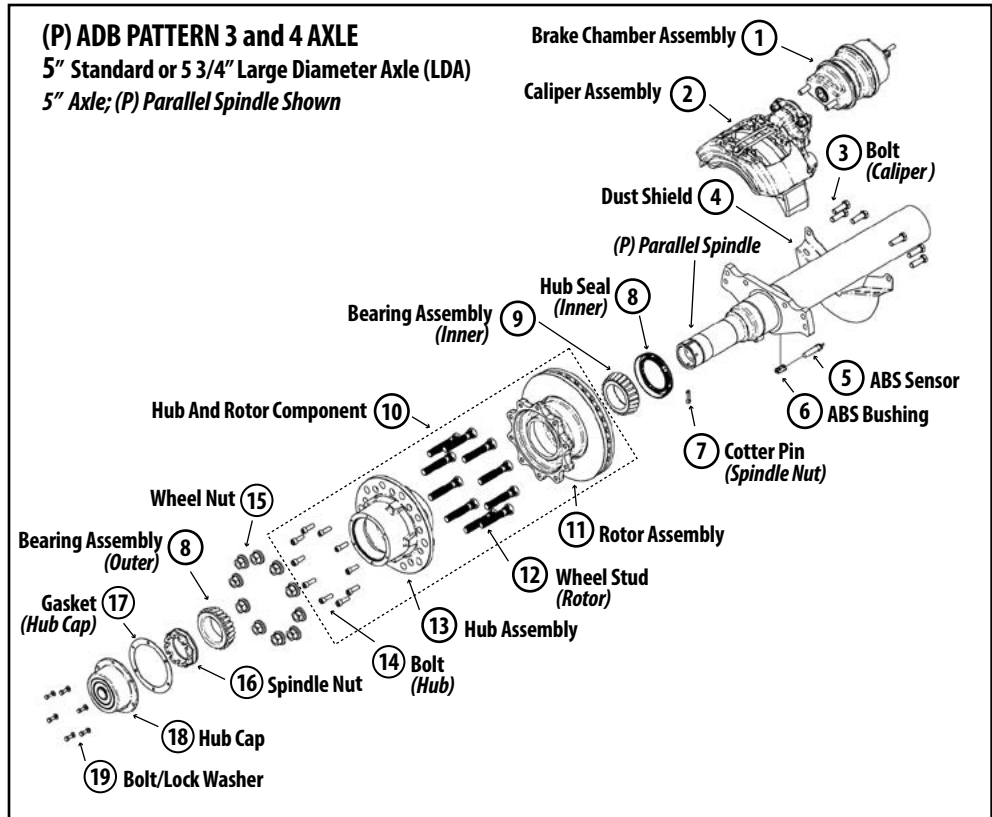

DIAG No.	QTY/Axle	Part No.	Item Description
1	1	1660428	SPG BRK CHMBR ASY (18/24), 45 Deg. (20K/23K brake rating)
	1	1660429	SPG BRK CHMBR ASY (18/24), 135 Deg. (20K/23K brake rating)
	1	1660351	SPG BRK CHMBR ASY, (20/24), 45 Deg. (20K brake rating)
	1	1660352	SPG BRK CHMBR ASY, (20/24), 135 Deg. (20K brake rating)
	1	1660203	SPG BRK CHMBR ASY, (24/24), 45 Deg. (23K brake rating)
	1	1660204	SPG BRK CHMBR ASY, (24/24), 135 Deg. (23K brake rating)
	1	1660456	Brake actuator, Service Only, Type 18 , 40 Deg.
	1	1660457	Brake actuator, Service Only, Type 18, 140 Deg.
2	1	1660433	Brake Actuator, Service Only, Type 20, 45 Deg.
	1	1660434	Brake Actuator, Service Only, Type 20, 135 Deg.
	1	1660205	Brake Actuator, Service Only, Type 24, 45 Deg.
	1	1660206	Brake Actuator, Service Only, Type 24, 135 Deg.
3	12	1130058	(5" Axle) Hex Head Cap Screw (HHCS) M16x1.5 x 50mm; GR 10.9
	10	1130056	(LDA) Hex Head Cap Screw (HHCS) M16-1.5 x 59mm; GR 10.9
	2	1130057	(LDA) Hex Head Shoulder Cap Screw (HHSCS) M16-1.5 x 59mm; GR 10.9
4	2	1660500	Dust Shield
5	2	1664702B010	ABS-Sensor (See page 16)
6	2	1664702B002	ABS - Bushing (See page 16)
7	2	1660373	Cotter Pin (Spindle Nut)
8	2	1660494	Hub Seal (Inner) - National Gold PTFE
	2	1660276	Hub Seal (Inner) - STEMCO Guardian® HP
9	2	1660304	Bearing Cone-3.5" ID (Inner/Outer)

Continued on next page



Continued from previous page

DIAG No.	QTY/Axle	Part No.	Item Description
10	2	1660466	Hub and Rotor Component (FP) - PAN 19
11	2	1660495	Rotor Assembly, PAN 19
12	16	1660083	Wheel Stud - M22 x 1.5; 4.79" length
13		Not Available	PAN 19 Hub Only, Cast
14	10	Not Available	Socket Head Cap Screw (SHCS) M12 x 1.75 35mm; GR 12.9
15	20	1660057	Wheel Nut
16	2	1660597	Spindle Nut (Castle Nut) Kit
17	2	1660055	Gasket (Hub Cap)
18	2	166xxxx	Hub Cap <i>Options-Oil or Hard/Semi-Fluid Grease Lubrication (See page 19)</i>
19	12	1144206B105	HHCS 5/16" - 18NC 3/4" length
	12	1164263B100	Lock Washer 5/16"

**17.5" WHEEL SIZE –  
WABCO CALIPER**

See 164– Dressed-Axle Part Number Definitions on page 4 for axle identification.

164xxxSxxxx – Wabco Caliper

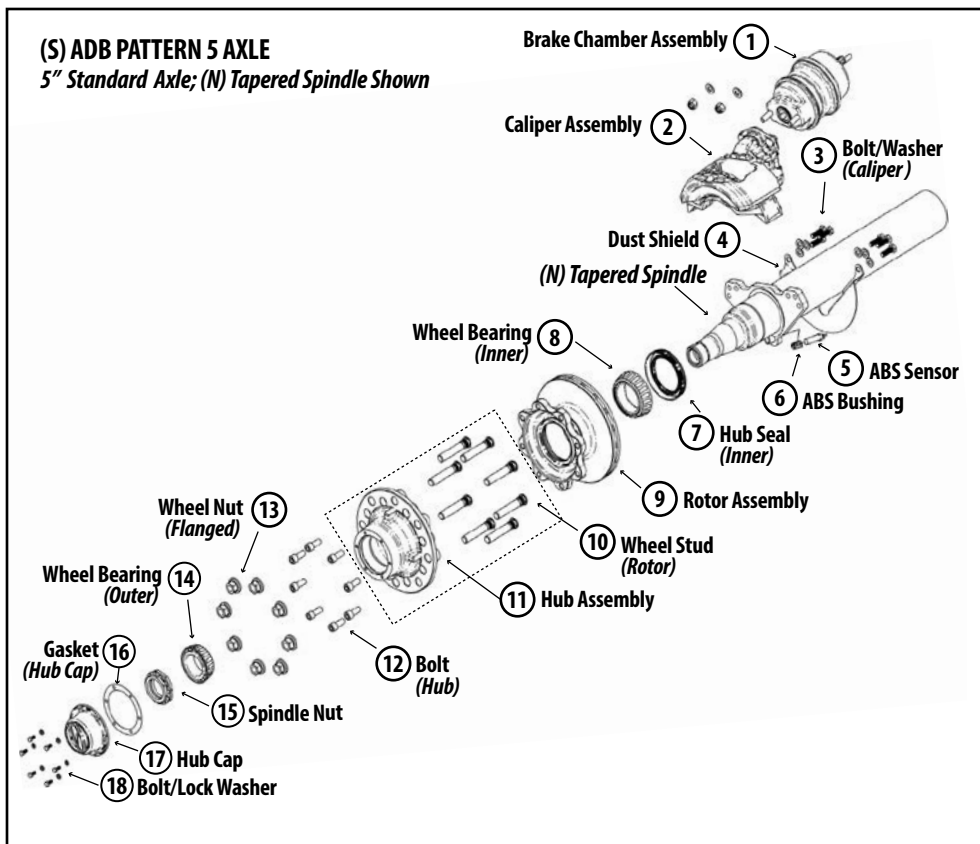

DIAG No.	QTY/Axle	Part No.	Item Description
1	1	1660351	SPG BRK CHMBR ASY, (20/24), 45 Deg. (20K brake rating)
	1	1660352	SPG BRK CHMBR ASY, (20/24), 135 Deg. (20K brake rating)
	1	1660433	Brake actuator, Service Only, Type 20, 45 Deg.
	1	1660434	Brake actuator, Service Only, Type 20, 135 Deg.
2	1	1660462	Caliper Assembly (Left-Hand)
	1	1660463	Caliper Assembly (Right-Hand)
	1	1660497	Pad Kit, PAN 17 (Not Shown)
3	12	1140093	Hex Head Cap Screw (HHCS) M14-1.5 X 45mm; GR 10.9
	12	1160030	Flat Washer, M14
4	1	1660503	Dust Shield
5	2	1664702B010	ABS-Sensor
6	2	1664702B002	ABS-Bushing
7	2	1660458	(Inner) Hub Seal - National Gold PTFE
8	2	1664206B008	(Inner) Wheel Bearing Cone (3.543" ID)
9	2	1660487	Rotor 325mm X 34mm, PAN 17
10	16	1660083	Wheel Stud M22x1.5; 4.79" length
11	2	1660488	Hub Assembly - FN, PAN 17
12	16	1130059	Socket Head Cap Screw (SHCS) M16-2.0 X 40mm
13	16	1660057	Flanged Wheel Nut
14	2	1664206B009	(Outer) Wheel Bearing (2.625 ID)
15	2	1664206B014	Spindle Nut Kit
16	2	1664206B007	Gasket (Hub Cap)
17	2	166xxxx	Hub Cap Options–Oil or Hard/Semi-Fluid Grease Lubrication (See page 19)
18	12	1144206B105	HHCS 5/16" - 18NC 3/4" length
	12	1164263B100	Lock Washer 5/16"

Wabco components fit both right-hand and left-hand caliper assemblies

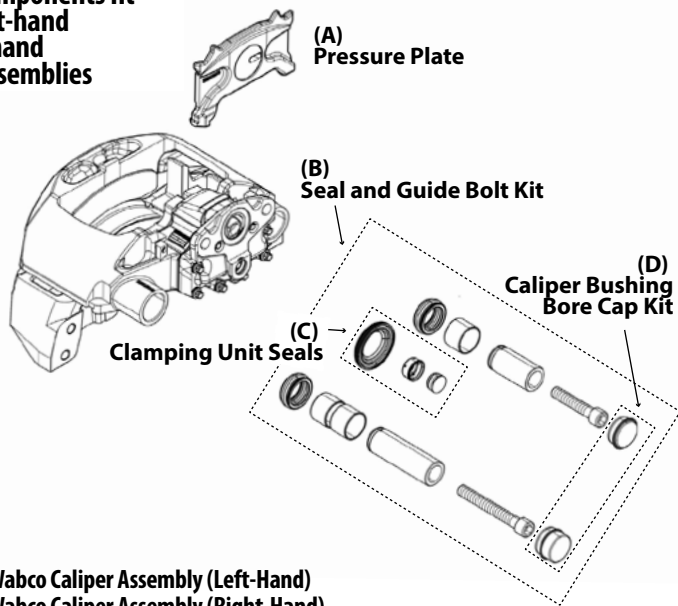

1660403 - Wabco Caliper Assembly (Left-Hand)  
1660404 - Wabco Caliper Assembly (Right-Hand)

Diagram No.	QTY (Per Axle)	Part Number	Item Description
<b>A</b>	1	1660557	Pressure Plate – PAN 17
	1	1660558	Pressure Plate – PAN 19
	1	1660559	Pressure Plate – PAN 22
<b>B</b>	2	1660498	Seal and Guide Bolt Kit – PAN 17
	2	1660390	Seal and Guide Bolt Kit – PAN 22
<b>C</b>	2	1660612	Seals for Clamping Unit – PAN 17; PAN 19; PAN 22
<b>D</b>	1	1660541	Caliper Bushing Bore Cap Kit – PAN 19; PAN 22
	1	Not Available	PAN 17 Tool kit – (Wabco #6401755212)
	1	6100068	PAN 19; PAN 22 Tool Kit (Basic)
	1	6100078	PAN 19; PAN 22 Tool Kit

**Bendix components fit both right-hand and left-hand caliper assemblies**

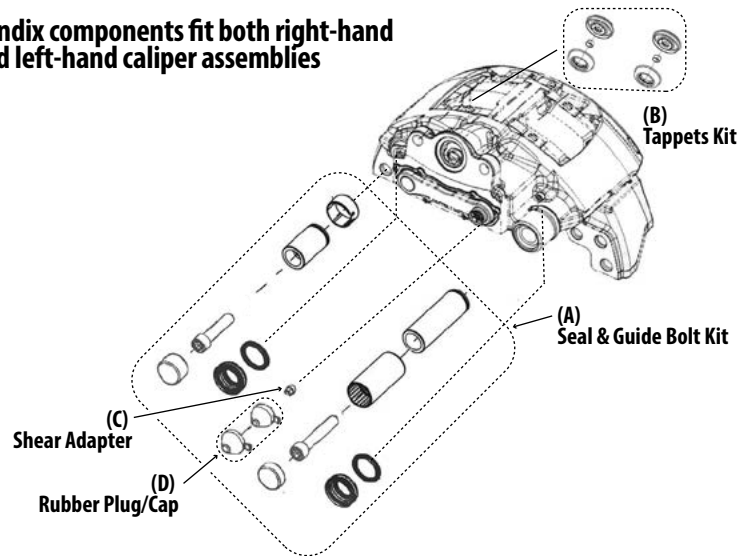

1660401-ADB22X Caliper Assembly (LH)  
1660402-ADB22X Caliper Assembly (RH)

1660528-ADB22X-LT Caliper Assembly (LH)  
1660529-ADB22X-LT Caliper Assembly (RH)

Diagram No.	QTY/Axle	Part No.	Item Description
A	2	1660443	Seal & Guide Bolt Kit
B	2	1660445	Tappets Kit ( <i>tappet and boot</i> )
C	2	1660451	Shear Adapter (Box of 10)
D	2	6040148	Rubber plug

**Haldex components fit both right-hand/left-hand caliper assemblies**

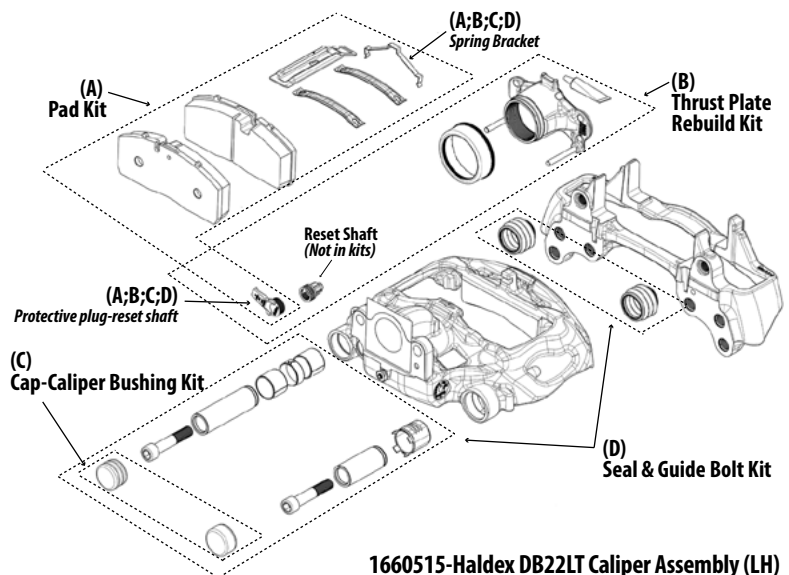



1660515-Haldex DB22LT Caliper Assembly (LH)  
1660516-Haldex DB22LT Caliper Assembly (RH)

Diagram No.	QTY/Axle	Part No.	Item Description
A	1	1660686	Pad Kit
B	1	1660687	Thrust Plate Rebuild Kit
C	1	1660688	Cap-Caliper Bush Kit
D	1	1660689	Seal & Guide Bolt Kit

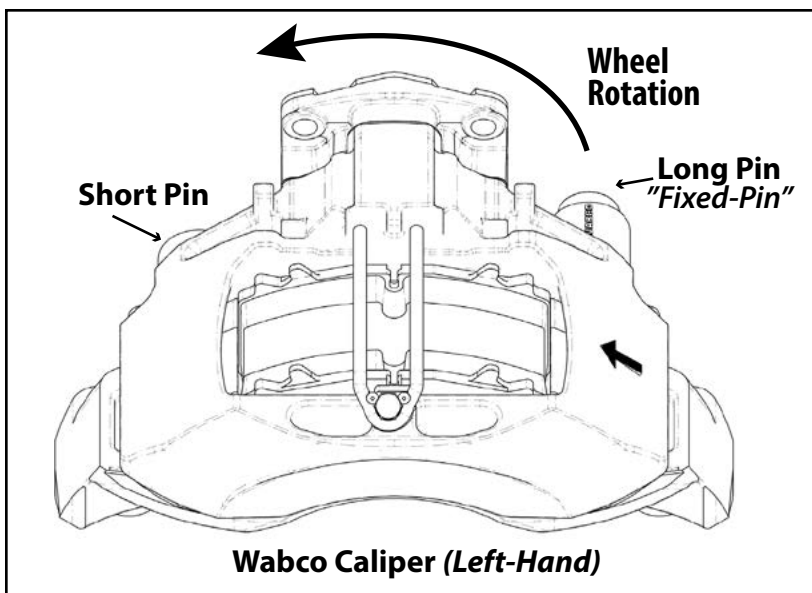
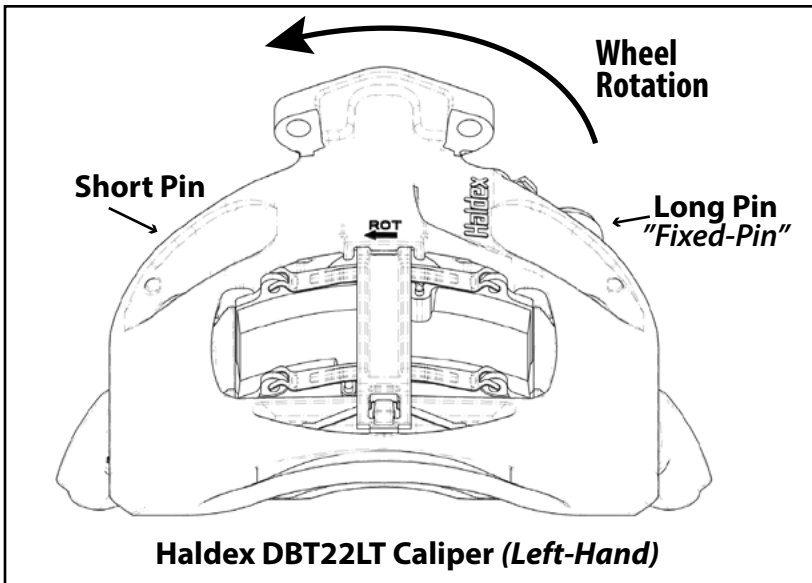
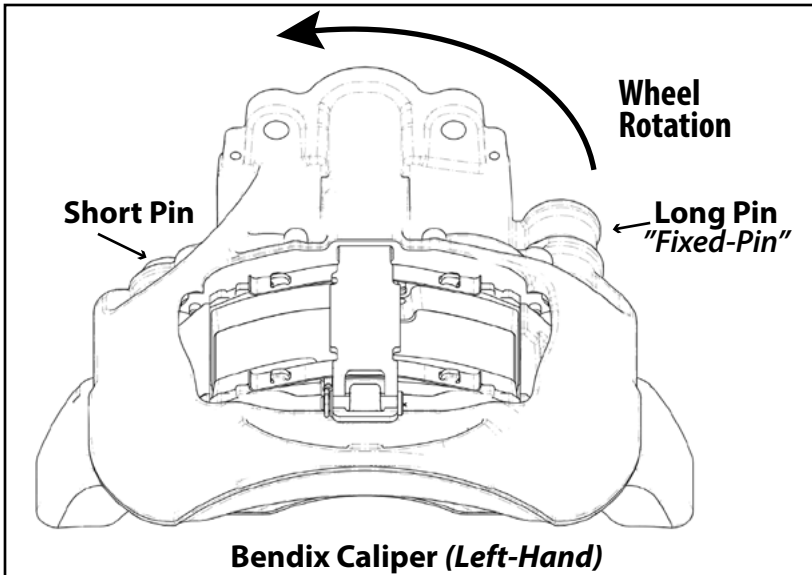
As the vehicle travels forward, the wheel rotates from "Long Pin" (Fixed-Pin) side towards the "Short Pin" side of the caliper.



**TORQUE SPECIFICATIONS –  
AXLE/WHEEL-END COMPONENTS**

<b>Component Type</b>	<b>Component Description</b>	<b>foot-pound</b>	<b>Newton-meter</b>
<b>Spindle Nut</b>	<i>Refer to the American Trucking Associations Technology &amp; Maintenance Council (TMC) Recommended Maintenance Practice #618 - Wheel Bearing Adjustment Procedure.</i>		
<b>Wheel Nut</b> <i>Hub-Piloted – Flanged</i> <i>Stud-Piloted – Ball-Seat</i>	M22 x 1.5 x 33 (1.30" x 1.22") 3/4" x 16	450-500 ft-lb 450-500 ft-lb	610-678 N-m 610-678 N-m
<b>Brake Chamber Mounting Fastener</b>	5/8" Mounting Hardware	110-150 ft-lb	149-203 N-m
<b>Auto. Slack Adjuster-to-Push Rod</b>	Jam Nut – pushrod-to-clevis	(5/8-18) 400 in-lb	45.19 N-m
<b>Air Disc Brake– Hub-to-Rotor Fastener</b>	<b>Pattern One</b> ( <i>Discontinued</i> ) Cast Iron Hub	229-258 ft-lb	310-350 N-m
	<b>Pattern Two</b> Gunitite® Cast Iron Hub (HHCS-5/8x11)	210-230 ft-lb	285-312 N-m
	KIC™ Cast Iron Hub (HHCS-M16)	220 ±10 ft-lb	298 ±14 N-m
	ConMet® Alum. Hub (Locknut required)	180-210 ft-lb	244-285 N-m
	<b>Pattern Three/Four</b> Wabco PAN™ 19	100-103 ft-lb	135-140 N-m
	<b>Pattern Five</b> Wabco PAN™ 17	180-200 ft-lb	244-271 N-m
<b>ADB Caliper – Mounting Fastener</b>	<b>Pattern One</b> ( <i>Discontinued</i> ) Wabco PAN™ 22 (HHCS-M16)	199-229 ft-lb	270-310 N-m
	<b>Pattern Two</b> Wabco PAN™ 22 (HHCS-M20)	342-395 ft-lb	464-536 N-m
	Bendix ADB22X™/ADB22X-LT™ (HHCS-M20)	Pre-Torque: 20-60 ft-lb Final: 350-400 ft-lb	27-81 N-m 475-542 N-m
	Haldex DBT22LT (HHCS-M20)	Pre-Torque: 145 ft-lb Final: 390 ±25 ft-lb	200 N-m 530 ±34 N-m
	<b>Pattern Three/Four</b> Wabco PAN™ 19 (HHCS-M16)	199-229 ft-lb	270-310 N-m
	<b>Pattern Five</b> Wabco PAN™ 17 (HHCS-M14)	118-148 ft-lb	160-200 N-m
<b>Hubcap Bolt</b>  Do not use motor-driven screw or torque tools on hubcap fasteners.	HHCS 5/16 18NC – 3/4" long (Lock Washer)	12-16 ft-lb (144-192 in-lb)	16-22 N-m
<b>Refer to original equipment manufacturer for complete torque specifications.</b>			
 <b>Failure to install/maintain fasteners at torque specifications could result in suspension failure and voided warranty.</b>			

**Ridewell suggests these Technology & Maintenance Council (TMC) Recommended Maintenance Practices:**

- RP 222 User's Guide to Wheels and Rims
- RP 604 Brake Chambers for Air-Braked Vehicles
- RP 607 Preventive Maintenance-S-Cam Foundation Brakes
- RP 608 Brake Drums and Rotors
- RP 609 Brake Adjuster Removal; Installation; Maintenance
- RP 618 Wheel Bearing Adjustment Procedure
- RP 619 Air System Inspection Procedure
- RP 622 Wheel Seal/Bearing Removal, Installation-Maintenance
- RP 631 Recommendations for Wheel End Lubrication
- RP 651 Steer Axle Maintenance Guidelines
- RP 652 Service and Inspection of Air Disc Brakes
- RP 656 Hub and Spoke Wheel Fastener Maintenance
- RP 708 Trailer Axle Alignment
- RP 728 Trailer Axle Maintenance
- RP 1503 Brake Maintenance - Severe Vocational Applications
- RP 1506 Torque Rod Maint Guidelines Vocational Vehicles
- RP 1509 Drive Axle Suspension Guidelines - Vocational Vehicles

**Recommended Service Intervals**

Ridewell Suspensions recommends these minimum service intervals for standard duty, on-highway usage suspension applications. More frequent intervals are recommended for heavier duty applications.

**Daily/Pre-Trip Inspections**

- \_\_\_ Check tires for proper inflation, damage/excessive wear.
- \_\_\_ Check oil-level in wheel hub. Inspect wheel-ends for obvious signs of lubricant leakage. Check suspension/wheel ends for missing components.
- \_\_\_ Visually inspect suspension structure for damage/excessive wear.
- \_\_\_ Check for loose/missing bolts/nuts. Check suspension components for irregular movement.
- \_\_\_ Make sure air controls are operating properly. Drain all moisture from air reservoirs.

**First 6,000 miles of use**

- \_\_\_ Torque all component bolts/nuts to specifications (Refer to Manufacturer's Specifications).
- NOTE: Do not re-torque shear-type pivot bolt.

**Every 12,000 miles of use**

- \_\_\_ Inspect air springs for damage/excessive wear. Torque air spring bolts/nuts to Manufacturer's Specifications.
- \_\_\_ Check air lines and connections for leaks.

**Every 50,000 miles of use**

- \_\_\_ Torque all component bolts/nuts to specifications (Manufacturer's Specifications).
- \_\_\_ Lube camshaft bushings/brake adjusters.

**S-Cam Lubrication**

S-Cams should be lubricated monthly. More frequent service intervals may be needed in some applications.

NOTE: Extended wear in the bushing area, flat spots on the cam head or distorted splines will require a cam replacement.

- Clean grease fitting and surrounding area before lubricating any vehicle component. Lubricate S-Cam support grease fittings with #2 EP NLGI chassis lube.
- Standard Cam Axle - Add lubricant to both grease fittings until fresh grease can be seen purging from each bushing cavity. Wipe away excess grease.
- Covered-Cam Axle - Add lubricant to the spider-end grease fitting until grease is seen purging from the slack adjuster-end of cam cover. Wipe away excess grease.

**Annually/100,000 miles of use**

- \_\_\_ Inspect pivot connection for worn pivot bushings and wear washers. Replace components as necessary.
- \_\_\_ Torque suspension components to OEM torque specifications.
- \_\_\_ Check arm beam-to-axle welds.

**Check lubrication level in wheel ends:**

- \_\_\_ 1) Oil-Filled Wheel Ends:  
Refill/Replace lubricant as needed (RP 631 "100K/Annual Inspection").
- \_\_\_ 2) Semi-Fluid Grease:  
Pull outer bearing and visually inspect lubrication level. Replace as needed (RP 631 "Level 3 Lubrication Level Inspection") (RP 618 "Wheel Bearing Adjustment").
- \_\_\_ Check air lines/connections for leaks.
- \_\_\_ Check disc/drum brake air chambers and slack adjusters.
- \_\_\_ Inspect brake rollers, roller shafts, anchor pins and bushings. Replace if necessary.
- \_\_\_ Check shoes for bent shoe ribs, cracks in shoe table welds or ribs, and elongated rivet holes. Replace shoes if necessary.

**CAUTION** Failure to torque suspension components to specifications can result in suspension failure and void the warranty.

**Available Wheel-End Lubricants**

Lubricant Type	Part Number	Item Description
Mineral Oil	380008G	CITGO MP Gear Oils - 80W-90
Synthetic Oil	1980006	SHELL Spirax S6 AXRME API GL-5 - 75W-90
Synthetic Semi-Fluid Grease	1980011	CHEVRON Delo® Syn-Grease™ SFE EP
Synthetic Hard-Pack Grease	1980007	CITGO Mystik JT-6 NLGI-2 GC-LB

**Disc Brake Chamber Part Number - Listed by ports location on suspension after standard installation\***

*(Suspension Model (Type) Part Number starts with the number "2" or "300" followed by numbers/characters that group the suspension into a product family. The "X" symbol is used as a placeholder (wild card) for both numbers and characters in the Suspension Model Part Number.)*

Chamber Port Away from Axle-Long Pin Side		
<b>215xxxx</b>	<b>Truck and Trailer</b>	
<b>266x2xxxxDB</b>	<b>Low Mount (Underslung)</b>	
Chamber Size	P/N-Driver's Side	P/N-Curb Side
**T-16	1660452	
T-18	1660457	1660456
T-20	1660434	1660433
T-24	1660205	1660206
16/24	1660581	1660580
18/24	1660428	1660429
18/24	1660567	1660566
20/24	1660351	1660352
24/24	1660203	1660204

Chamber Port Towards Axle-Long Pin Side		
<b>240xxxx</b>	<b>Overslung;Underslung;Yoke</b>	
<b>260xxxx/200xxxx</b>	<b>Overslung</b>	
<b>266x1xxxxDB</b>	<b>Overslung</b>	
<b>266x3xxxxDB</b>	<b>Overslung</b>	
<b>233xxxx</b>	<b>Truck and Trailer</b>	
Chamber Size	P/N-Driver's Side	P/N-Curb Side
**T-16	1660452	
T-18	1660456	1660457
T-20	1660433	1660434
T-24	1660206	1660205
16/24	1660580	1660581
18/24	1660429	1660428
18/24	1660566	1660567
20/24	1660352	1660351
24/24	1660204	1660203

Chamber Port Away from Axle-Short Pin Side		
<b>2400209</b>	<b>Yoke</b>	
<b>245xxxx</b>	<b>Truck and Trailer</b>	
Chamber Size	P/N-Driver's Side	P/N-Curb Side
**T-16	1660452	
T-18	1660456	1660457
T-20	1660433	1660434
T-24	1660206	1660205
16/24	1660580	1660581
18/24	1660429	1660428
18/24	1660566	1660567
20/24	1660352	1660351
24/24	1660204	1660203

Chamber Port Towards Axle-Short Pin Side		
<b>266x4xxxxDB</b>	<b>Low Mount (Underslung)</b>	
Chamber Size	P/N-Driver's Side	P/N-Curb Side
16/24	1660581	1660580
18/24	1660428	1660429

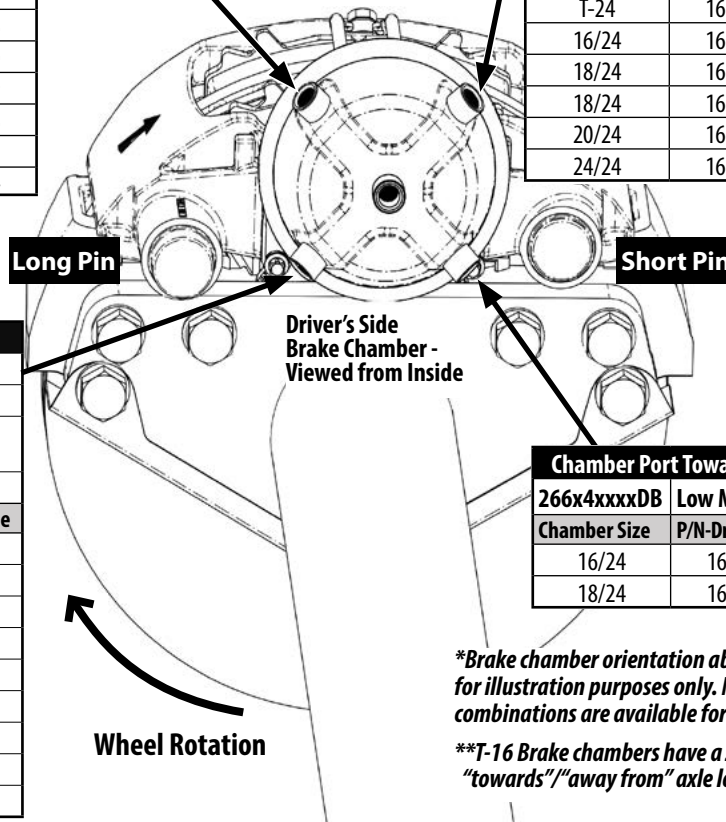

*\*Brake chamber orientation above the axle is shown for illustration purposes only. Not all ADB chamber combinations are available for each suspension type.*

*\*\*T-16 Brake chambers have a zero-degree port – "towards"/"away from" axle locations do not apply.*

Replacement of the disc brake chamber and the integration into the vehicle's air system depends upon the side of the axle where it's installed and the brake chamber ports location - either towards or away from the axle body.

In some cases, the correct brake assembly for the left-hand (driver's side) or the right-hand (curb side) side of the axle will be indicated by an arrow on the caliper.

The brake disc's direction of rotation during forward driving can be found by looking for the Long ("Fixed Position") Pin on the caliper assembly. The wheel rotates forward (towards) the long pin to the Short ("Floating Position") Pin.

In addition to showing wheel rotation, the location of the ADB chamber ports in relation to the axle (towards or away) will be indicated by the short or long pin (side) of the brake caliper.

Refer to the American Trucking Associations Technology & Maintenance Council (TMC) Recommended Maintenance Practices "(604) Brake Chambers for Air-Braked Vehicles" and "(652) Service and Inspection of Air Disc Brakes" for additional maintenance/replacement information.



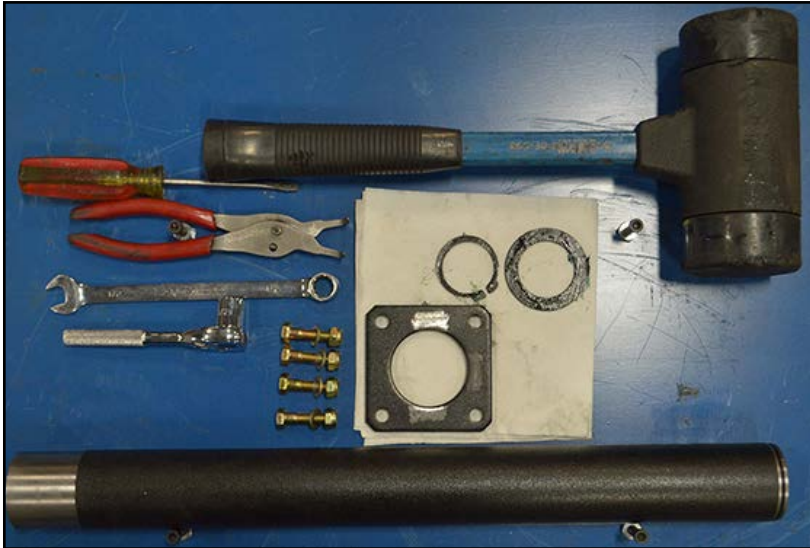

**Drum Brake Axle - Cam Cover Service Kit includes the brake cam enclosure, the brake cam support bracket and hardware components for one cam cover replacement.**

### Trailer Preparation

Park trailer on level surface. Set trailer parking brakes. Chock wheels on the axle that is not being raised.

Disconnect linkage from the height control valve(s), if necessary. Exhaust all air from the air system.

**CAUTION** Failure to provide support, chock vehicle's wheels or exhaust the air system could allow vehicle movement that could result in serious injury.

### Drum Brake Axle - Cam Enclosure Replacement

All work should be completed by a properly trained technician using the proper tools and safe work procedures.

Ridewell Suspensions recommends the cam enclosure be replaced on both sides of the drum brake axle at the same time.

1. Raise vehicle (axle) on the side of the cam cover to be replaced until wheel(s) clear the surface. Support with safety stands.
2. Remove the tire/wheel assembly and the hub/drum components to access the axle spider. Remove the slack adjuster/clevis assembly and brake components to access the inboard brake cam mounting bracket.
3. Use snap-ring pliers and a flat-head screwdriver to remove the snap-ring and flat washer(s) from the splined end of the brake cam (slack adjuster end).
4. Remove the bolts; flat washers; and, locknuts holding the Cam Cover Support Bracket to the Brake Cam Mounting Bracket. NOTE: Inspect hardware for damage. Replace components as necessary.
5. Tap on the splined end of the brake cam with a rubber mallet to loosen. Pull the brake cam out from the outboard side of cam enclosure. Inspect brake cam for damage. Replace if necessary.

*Continued on next page*



**Remove hardware from mounting bracket. Tap the splined end of brake cam with rubber mallet. Pull cam out of the outboard side of cam enclosure.**

*Continued from previous page*

6. Remove cam cover from mounting brackets. Inspect O-Ring Seal and Lip Seal for damage/excessive wear. Replace as necessary.
7. Inspect thrust washer, cam bearing, outboard cam seal and inside the axle spider for damage. Replace components as necessary.
8. Welding preparation - Grind away a small amount of paint on three (3) sides of the hole in the cam cover support bracket.
9. Place the cover support bracket on the end of cam cover with lip seal. Rotate the bracket so that one weld area is on the outside of mounting bracket; away from the axle.
10. Insert the ground (shiny) end of cam cover through the inboard side of the mounting bracket into the bearing inside the axle spider. Hold the cam cover support bracket against the mounting bracket. Tap the inboard side of the cam cover with rubber mallet to firmly seat cover inside the axle spider.
11. Bolt the cam cover support bracket to the mounting bracket.
12. Push the brake cam through the outboard opening of cam cover until the groove on the splined end of cover appears on inboard side of the cam cover support bracket.
13. Thread flat washer over splined end of cam until it rests against the end of the cam cover.
14. Push snap ring onto splined end of cam until it rests against groove. Use flat head screwdriver to push snap ring into groove.
15. Tack-weld cam cover to the cover support bracket on the top, bottom and the bracket side that is away from the axle.
16. Lubricate brake cam using the axle spider grease fitting. Add grease until grease purges out the slack adjuster side of the cam cover support bracket. Wipe away excess.
17. Reattach brake components. Reassemble hub/drum assembly. Reattach any other wheel-end components that were removed.
18. Replace tire/wheel assembly. Raise vehicle and remove support stands. Lower vehicle to ground.

Repeat brake cam cover replacement procedure on the other side of axle.



**Inspect the cam bearing (inside axle spider); the cam bearing seal; and, the thrust washer for damage. Replace components as necessary.**

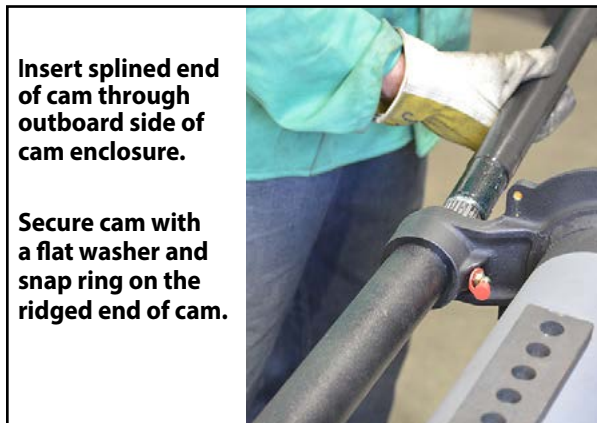

**Insert splined end of cam through outboard side of cam enclosure.**

**Secure cam with a flat washer and snap ring on the ridged end of cam.**

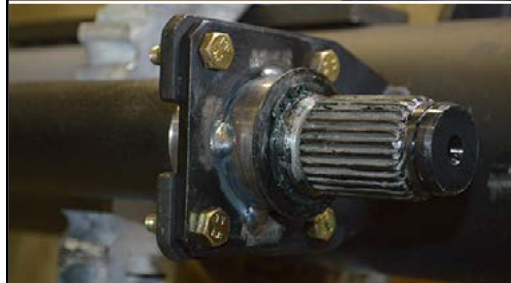

**Pressure Systems International (P.S.I.)<sup>®</sup> ThermALERT™**  
[www.psitireinflation.com/resources](http://www.psitireinflation.com/resources)

**ATIS Installation – Axle Preparation Options**

<b>Basic (1-Hole)</b>	One 1/8" NPT hole drilled and tapped in the top center of the axle.* Includes Plug.
<b>Basic (3-Hole)</b>	Three 1/4" NPT holes drilled and tapped in the top of the axle (10" spacing).* Includes Plugs.
<b>Axle Fully Prepped</b>	Basic axle preparation plus wheel-end component drill/tap and ATIS air-fittings installation. NOTE: Air system connection hoses not included.
<i>*Note: Do not use a drill for tapping the axle. The use of a drill can lead to breaking the tap or the hole threads running too deep inside the axle for proper installation.</i>	

An automatic tire inflation system (ATIS) is designed to monitor and maintain the correct air pressure inside the vehicle tires.

**ATIS Operation**

The automatic tire inflation system redirects pressurized air from the vehicle's air system to the tires in order to maintain the proper air pressure. An ATIS monitor system reports real-time tire-pressure information to the driver with a low-pressure warning light.

**Advantages of an ATIS**

**Extended Tire Life:** Under-inflated tires are the main cause of tire failure and contribute to tire disintegration, heat buildup, ply separation and sidewall/casing breakdowns.

In addition, tires that are properly inflated improve fuel economy while adding greater stability, handling and braking efficiencies for increased vehicle safety on the road.

Contact Ridewell Customer Service for the axle and wheel-end preparation needed for a single- or dual-wheel ATIS system.

**Terms and coverage in this warranty apply only to the United States and Canada.**

Ridewell Suspensions warrants the suspension systems manufactured by it to be free of defects in material and workmanship. Warranty coverage applies only to suspensions that have been properly installed, maintained and operated within the rated capacity and recommended application of the suspension. The responsibility for warranty coverage is limited to the repair/replacement of suspension parts. The liability for coverage of purchased components is limited to the original warranty coverage extended by the manufacturer of the purchased part.

All work under warranty must have prior written approval from the Ridewell warranty department. Ridewell has the sole discretion and authority to approve or deny a claim and authorize the repair or replacement of suspension parts. All parts must be held until the warranty claim is closed.

Parts that need to be returned for warranty evaluation will be issued a Returned Materials Authorization (RMA). Parts must be returned to Ridewell with the transportation charges prepaid. The transportation charges will be reimbursed if the warranty claim is approved.

This non-transferable warranty is in lieu of all other expressed or implied warranties or representations, including any implied warranties of merchantability or fitness or any obligations on the part of Ridewell. Ridewell will not be liable for any business interruptions, loss of profits, personal injury, any costs of travel delays or for any other special, indirect, incidental or consequential losses, costs or damages.

**Contact the Ridewell Warranty Dept. at 417.833.4565 - Ext. 135, for complete warranty information.**