

PAN[®]17 – MECHANICAL SLIDING CALLIPER DISC BRAKE

ASSEMBLY AND MAINTENANCE INSTRUCTIONS

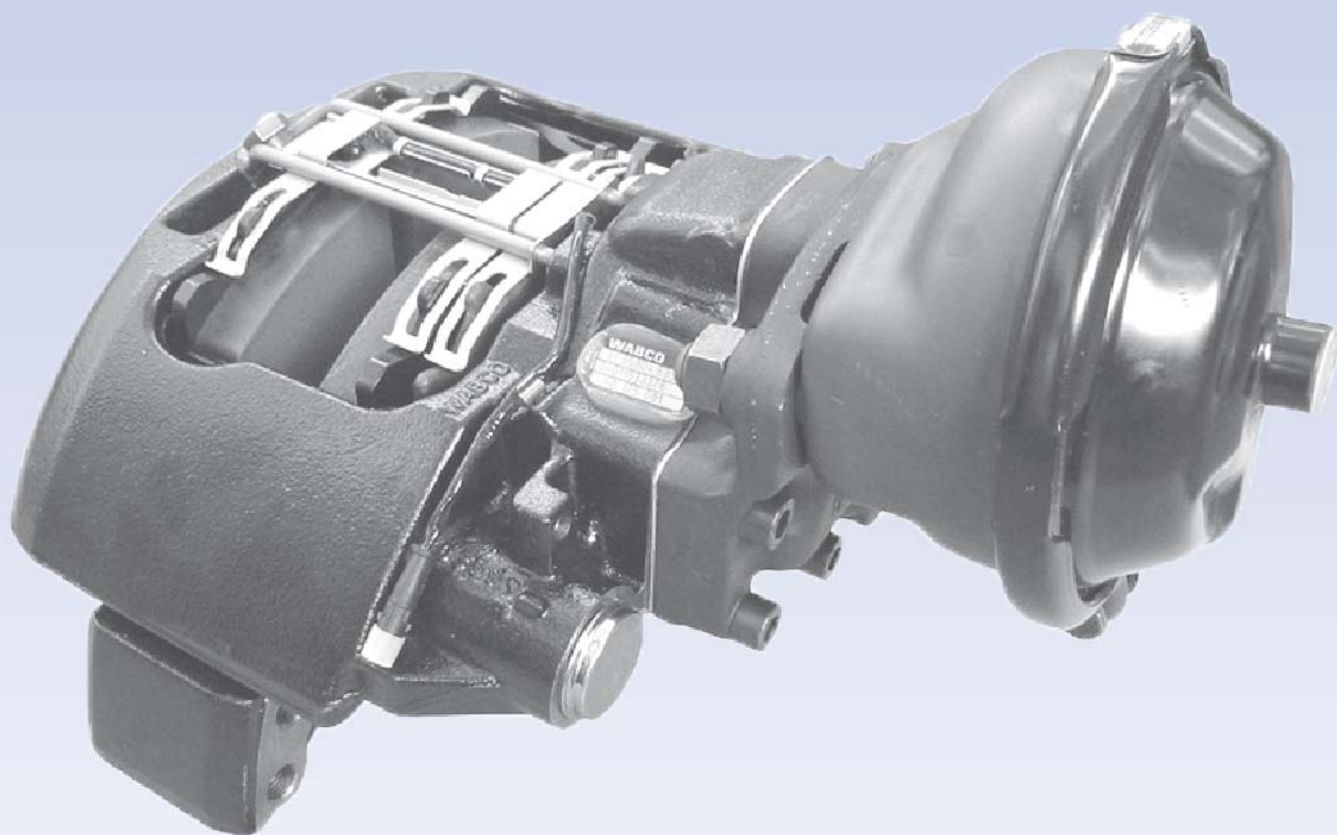

WABCO

PAN[®]17
MECHANICAL SLIDING CALLIPER
DISC BRAKE

Assembly and Maintenance
Instructions

2nd edition

This publication is not subject to an updating service.
You will find the current version at

<http://www.wabco.info/8150100653>

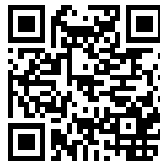

© 2013 WABCO Europe BVBA – All rights reserved

WABCO

Subject to change without notice
Version 1/07.2013(en)
815 010 065 3

1 Important instructions and safety instructions . 3	6 Replacing the seals 23
1.1 General information 3	6.1 Replacing the protection caps and the bushings of the guide pins 23
1.2 Safety instructions 3	6.1.1 Disassembly 23
1.2.1 Risk of accidents 3	6.1.2 Assembly 25
1.2.2 Risk of injury 3	6.2 Replacing the protection cap of the adjuster screw 28
1.3 Repair and maintenance instructions 4	6.2.1 Removing the protection cap 28
2 Description of the mechanical sliding calliper disc brake 5	6.2.2 Installing the protection cap 30
3 Checking the brake 8	6.3 Replacing the protection cap of the adjuster screw 30
3.1 Checking the automatic adjuster 8	6.3.1 Installing the protection cap 30
3.2 Checking the brake linings 9	7 Replacing the brake cylinder 33
3.3 Checking the brake discs 10	7.1 Removing the brake cylinder 33
3.3.1 Checking the condition of the brake disc 10	7.2 Installing the brake cylinder 33
3.3.2 Checking the brake disc runout 11	7.3 Removing the spring brake actuator 34
3.3.3 Checking the bearing play of the guide pin 11	7.4 Installing the spring brake actuator 35
4 Replacing the brake linings 13	8 Annex 36
4.1 Removing the brake linings 13	8.1 WABCO tools 36
4.2 Checking the protection caps and the mobility of the brake calliper 15	8.2 Widths AF and tightening torques 37
4.3 Fitting the brake linings 17	8.3 Exploded view of the replacement parts 38
5 Replacing the brake 20	8.4 Procurement and disposal of spare parts. 39
5.1 Removing the brake 21	8.4.1 Procurement of the spare parts 39
5.2 Installing the brake 21	8.4.2 Disposal of the brake parts 39

1 Important instructions and safety instructions

1.1 General Information

This publication describes the maintenance and repair of the PAN[®]17 disc brakes including the individual operations and work processes required to replace components using available repair kits.

Wheel brake product numbers:

40 175

640 175 ...

This publication is directed at trained service technicians employed at workshops for commercial vehicles.

- Before you begin with maintenance, repair, replacing a part etc., carefully read all the safety instructions as well as the repair and maintenance instructions included in this publication. These instructions must be observed to avoid personal injury and/or material damage.
- WABCO only guarantees the safety, reliability and performance of its products and systems if all instructions, notes and safety instructions are observed.

Before you perform any work on the vehicle (repair, maintenance, replacing parts, etc.), you must ensure the following:

- Only trained and qualified personnel may perform repairs on the vehicle.
- Always follow the specifications and instructions of the axle or vehicle manufacturers.
- Always comply with the Company and national accident prevention guidelines and Health and Safety regulations.
- Wear suitable protective clothing as the situation requires.
- The workplace has to be dry, as well as sufficiently lit and ventilated.

1.2 Safety information

1.2.1 Danger of accidents



WARNING!

Reduced braking effect or brake failure

- Regularly check the wear limits of brake linings and brake discs.
- Replace worn, scorched, glazed, or oily brake linings immediately.
- Immediately replace worn or damaged brake discs.
- Always replace brake linings by axle and use a new retaining system for brake linings and pressure plates.



WARNING!

Rolling vehicle

- Position the vehicle on an even surface and secure it against rolling away with brake wedges.
- Only use approved devices to jack up and secure the vehicle.
- Make sure that the transmission is in neutral and the hand brake has been applied.



WARNING!

Rolling vehicle

- Make sure that the release screw of the spring brake cylinder is threaded completely in after completing the maintenance and installation work and check the functionality of the hand brake.

1.2.2 Risk of injury



CAUTION!

Hazardous dusts

- Do not clean any soiled areas of the brake with compressed air or other high-pressure devices.



CAUTION!

Heavy load

- A second technician must assist during removal and installation of the brake.

**CAUTION!
Brake action while working on the brake**

- Attach a clearly marked note on the steering wheel saying that work is being performed on the vehicle and that the brake must not be touched.

**CAUTION!
Crushing of fingers**

- Only grip the brake on the outside with your hands while moving the brake calliper or working on the brake.
- Do not use motor-driven screw or torque tools.

**CAUTION!
Falling brake parts and high tightening and loosening torques**

- Use suitable equipment, such as a vice, to clamp the brake when performing repairs on the brake outside the vehicle.

1.3 Repair and maintenance instructions

For good handling and good braking characteristics it is essential that the disc brake is in flawless technical condition.

- If cast parts have been heavily damaged or are severely worn, (cracks for example), replace the entire brake following the instructions.
- Never use the lining retainer (38) as a grab handle or for fastening a lifting device, because the retainer can be damaged in the process.
- Do not open the brake calliper with the clamping unit and do not loosen the retaining screws on the calliper cover.
- Do not apply the brake when brake linings have been removed.
- Do not use compressed air or other high-pressure devices when cleaning the brake or the vehicle. This may result in the risk of personal injury or hazardous dusts. Rubber parts of the brake could also be damaged.
- Only use original WABCO parts and approved brake linings and retaining systems for brake linings and pressure plates. An exploded view of replacement parts is found in the annex of this document (see chapter 8.3 „Exploded view of the replacement parts“, page 38).
- Only use grease contained in the repair kits.
- Perform the repair work using only the recommended tools (see chapter 8.1 „WABCO tools“, page 36). Do not use motor-driven screw or torque tools.
- Tighten screws and nuts only with the specified spanners, applying only the specified tightening torque; refer to the table in Annex (see chapter 8.2 „Widths across flats and tightening torques“, page 37) for the corresponding positions.
- Perform a concluding roller test stand test having completed the repairs. If no roller test stand is available, conduct a test drive with brake action tests.
- Do not perform full braking, with the exception of emergency braking, during the first 50 km after new brake linings have been fitted. Also avoid continuous braking over longer periods. Ensure that the driver of the vehicle is informed.

2 Description of the mechanical sliding calliper disc brake

The PAN[®]17 brake is a pneumatic one-piston brake. It is designed for use in commercial vehicles on front and rear axle as service, auxiliary and hand brakes. It is actuated mechanically via a diaphragm brake cylinder or a spring brake actuator. The latter is fitted directly onto the brake calliper, thereby reducing the overall axial length of the brake. This enables optimal utilisation of the installation situations.

The entire disc brake consists of brake cylinder, brake calliper (1), and brake anchor plate (2).

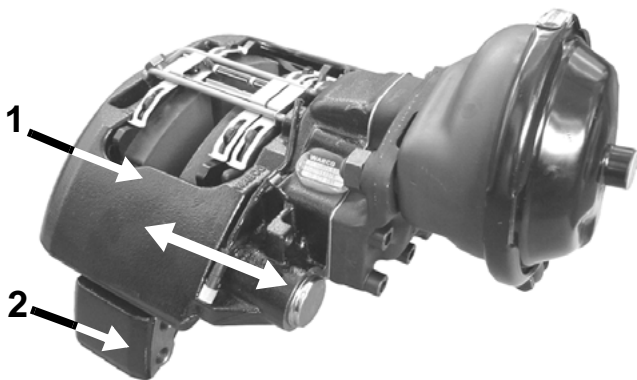

Fig. Entire disc brake

- 1 Brake calliper
- 2 Brake anchor plate

Arrow Brake calliper shifting directions

Functional description

The brake calliper (1) moves axially on guide pins (8, 9) of the brake carrier (2). The brake linings (35, 36) are guided and supported axially movable in the brake carrier. The brake lining support is implemented by means of a retainer (38) and hold-down springs (37).

The radially open design of the brake calliper enables simple and quick brake lining replacements. Linings with a large wear volume are used in order to prolong the replacement intervals.

For compensating the pad wear the actuating mechanism of the brake is equipped with a force-dependent, stageless, automatic adjuster mechanism. This mechanism maintains a preset clearance regardless of load and operating conditions. This, together with the stable and stiff construction of the brake calliper, results in safe control of the pedal travel and increases the reserve of travel for emergency braking.

All rubber parts and the grease fillings are maintenance-free except when damaged.

The disc brake is optionally equipped with an electrical wear indicator (threshold indicator).

When the indicator in the vehicle lights up, the residual lining thickness has been reached. It is necessary to drive the vehicle to a workshop for the brake linings to be replaced.

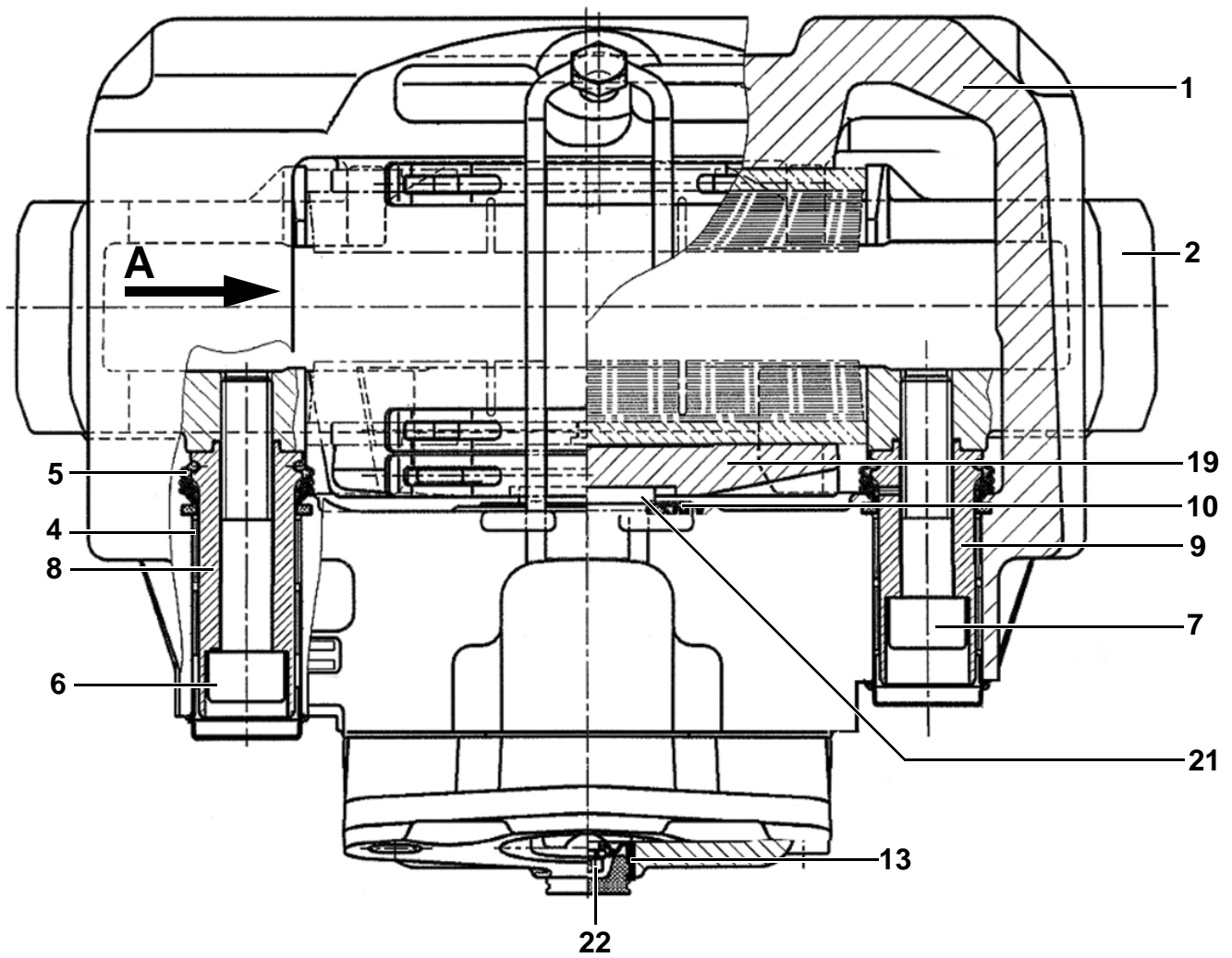

Fig. Top view and sectional view (left brake)

- | | | | |
|---|-------------------------------|----|--|
| 1 | Brake calliper | 9 | Guide pin (short) |
| 2 | Brake anchor plate | 10 | Protection cap for adjuster screw |
| 4 | Socket | 13 | Protection cap |
| 5 | Protection cap | 19 | Pressure plate |
| 6 | Hexagon socket screws (long) | 21 | Adjuster screw |
| 7 | Hexagon socket screws (short) | 22 | Hexagon of the adjuster |
| 8 | Guide pin (long) | A | Forward direction, direction of rotation |

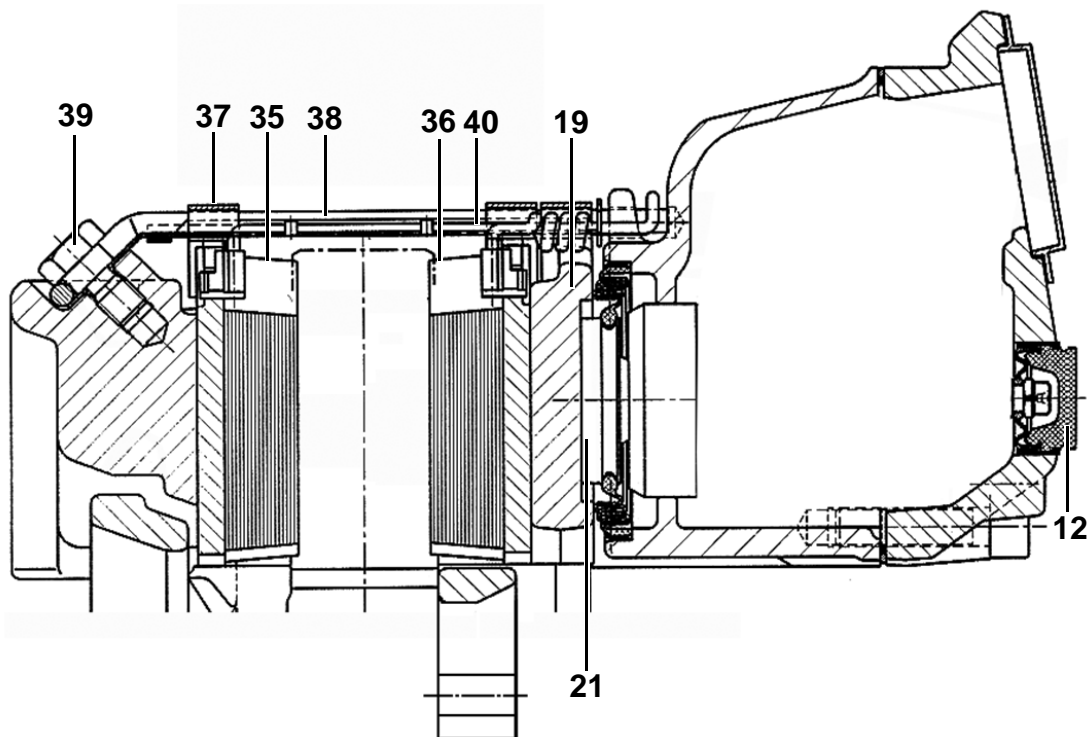

Fig. Side view and sectional view (left brake)

- | | | | |
|----|-----------------------------|----|------------------|
| 12 | Sealing plug for adjustment | 37 | Hold-down spring |
| 19 | Pressure plate | 38 | Lining retainer |
| 21 | Adjuster screw | 39 | Hexagon screw |
| 35 | Brake lining rim side | 40 | Cable guide |
| 36 | Brake lining cylinder side | | |

3 Checking the brake

3.1 Checking the automatic adjuster

- ! Directions of rotation and torques of the hexagon nut of the adjuster are listed in the table, item I (see chapter 8.2 „Widths across flats and tightening torques“, page 37).

Brake linings and pressure plate must be fitted in order to check the adjuster.

- Carefully remove the sealing plug (12) of the adjuster.

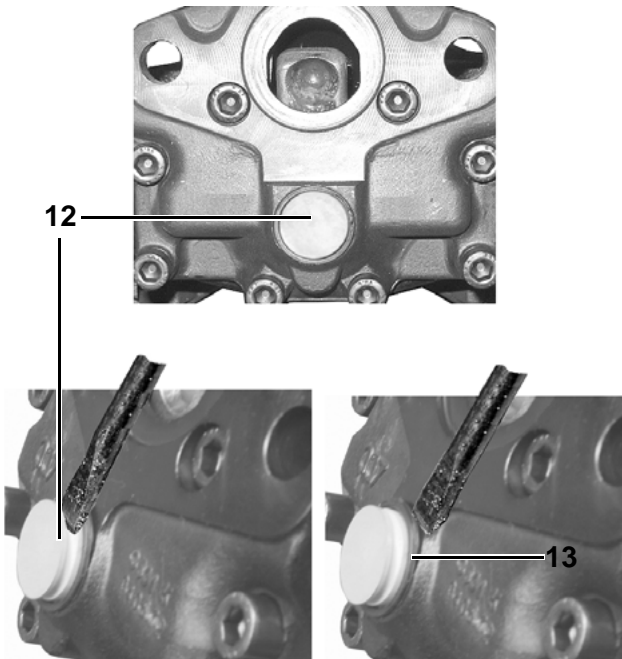

- ! When removing the sealing plug, apply the respective tool (such as a screwdriver) only to the sealing plug (12) and do not damage the closing cover (13) or the brake calliper.

- Check the protection cap (13) for wear and damage.
- If the protection cap (13) of the adjuster is damaged, replace it (see chapter 6.2 „Renewing the protection cap of the adjuster screw“, page 28).
- Use the ring spanner (tools 12 and 13) to turn the hexagon (22) of the adjuster by ½ turn in clockwise direction (see chapter 8.2 „Widths across flats and tightening torques“, page 37, table, item I).

- ! The adjuster can only be checked with increased clearance.

There must be sufficient space for the engaged ring spanner; it must not be obstructed when it is turned during adjustment.

Do not use an open-end spanner for the hexagon (22) of the adjuster and never overstrain the hexagon nut. Otherwise the hexagon will be damaged.

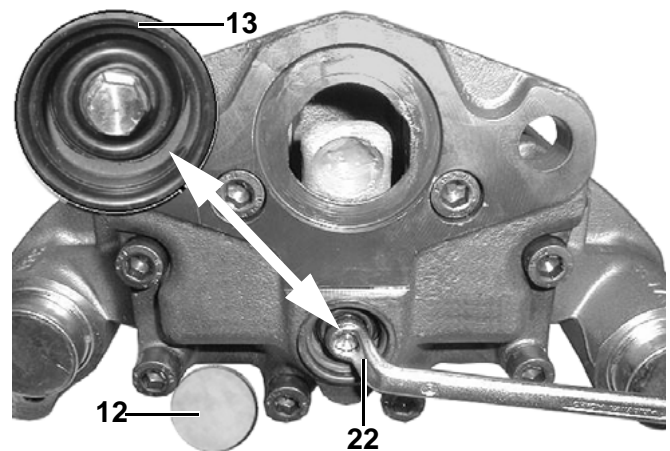

- Gently apply the brake 5 times (braking pressure approx. 1 bar).
If the adjuster functions correctly, the ring spanner will turn anticlockwise incrementally.

- ! With increasing adjustment the angle of rotation of the engaged ring spanner becomes smaller.

The adjuster is working correctly if the ring spanner rotates anticlockwise as described above.

Faults that might occur:

- The attached ring spanner does not rotate.
- The attached ring spanner only rotates with the first actuation.
- The attached ring spanner rotates back and forth with every actuation.

In the cases listed above, the adjuster is faulty and the brake must be replaced (see chapter 5 „Renewing the brake“, page 20).

- Reset the clearance to 1 mm having completed the adjuster test (see chapter 4.3 „Fitting the brake linings“, page 17).
- Remove the ring spanner (tools **12** and **13**) from the hexagon (22) of the adjuster.
- Insert the sealing plug (12) into the adjuster and ensure that the plug has a tight seat.

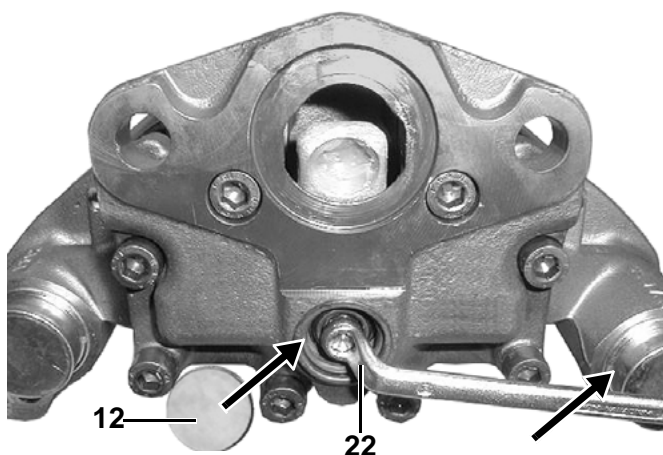

3.2 Checking the brake linings

! The brake lining thickness must be checked at regular intervals, in relation to vehicle use, during maintenance intervals, as well as in the context of applicable local laws and regulations.

Burned, glazed or oil-contaminated brake linings must be replaced immediately.

Always replace all brake linings by axle, using a new retaining system for brake linings and pressure plates.

To avoid damaging the brake disc replace the brake linings no later than at the point when they reach the wear limit at their weakest spot.

The residual lining thickness must not be allowed to become less than 2 mm above the backing.

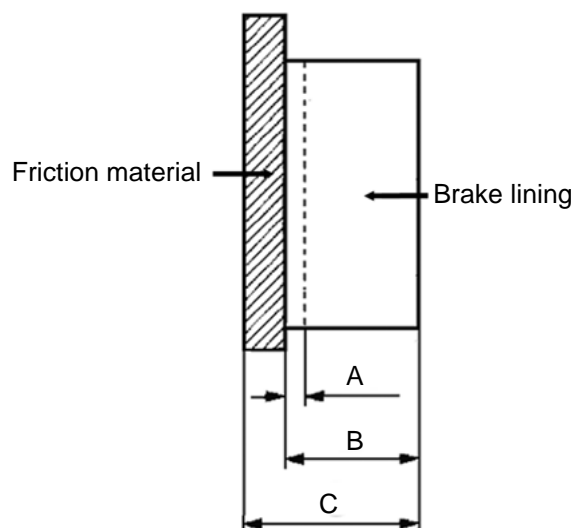

- A Residual lining thickness 2 mm
- B Total lining thickness 19 mm
- B Total thickness of new brake lining with lining carrier 26 mm
- Replace the brake linings when the wear limit (**A < 2 mm**) is reached or exceeded (see chapter 4 „Replacing the brake linings“, page 13).

3.3 Inspecting the brake discs

- Remove the brake linings (see chapter 4.1 „Removing the brake linings“, page 13).
- Measure the brake disc thickness at the contact area of the brake linings.

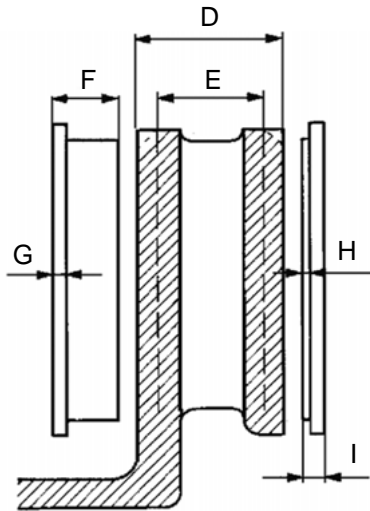

- D Overall thickness new brake disc 34 mm
- E Lining wear limit at least 28 mm
Replace the brake discs (by axle) if the wear measurement limit of 28 mm has been reached at the thinnest point.
- F Overall thickness new brake lining 26 mm
- G Brake lining supporting plate 7 mm
- H Minimum thickness brake lining 2 mm
- I Absolute minimum thickness brake lining and brake lining supporting plate 9 mm
Replace the linings as soon as the minimum thickness of 9 mm has been reached.



WARNING!

Risk of accident due to worn brake linings and worn brake discs

With worn brake linings and discs there is the risk of a reduced braking effect and even a failure of the brake.

- Regularly check the wear limits of brake linings and brake discs. Replace the linings as soon as the wear limit has been reached.

! The brake discs must be free of grease!

3.3.1 Checking the condition of the brake disc

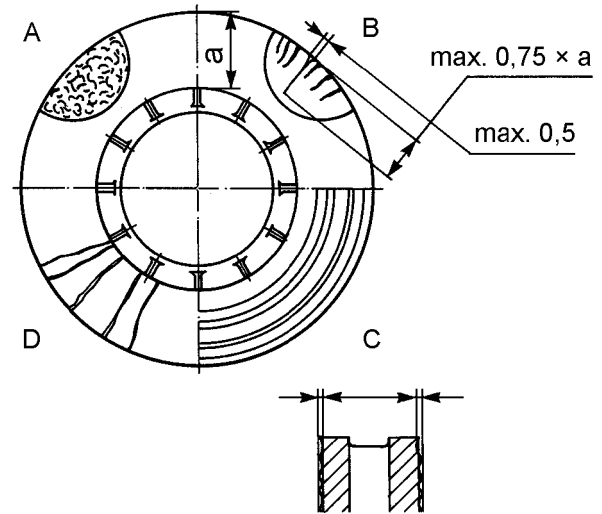

- A Web-like crack formation: permissible
 - B Radial cracks up to max. 0.5 mm width: permissible
 - C Unevenness of the disc surfaces up to max. 1.5 mm deep: permissible
 - D Continuous cracks: not permissible
 - a Width of the braking area
- Check the brake disc for cracks and the condition of the surface.
 - Replace the brake disc if the brake disc has continuous cracks or cracks or unevenness in excess of the permissible max. dimensions.

3.3.2 Checking the disc runout

- Fasten the dial indicator to the brake calliper.
- With the brake disc installed, check the disc runout by rotating the wheel hub.
Limit value: 0,15 mm

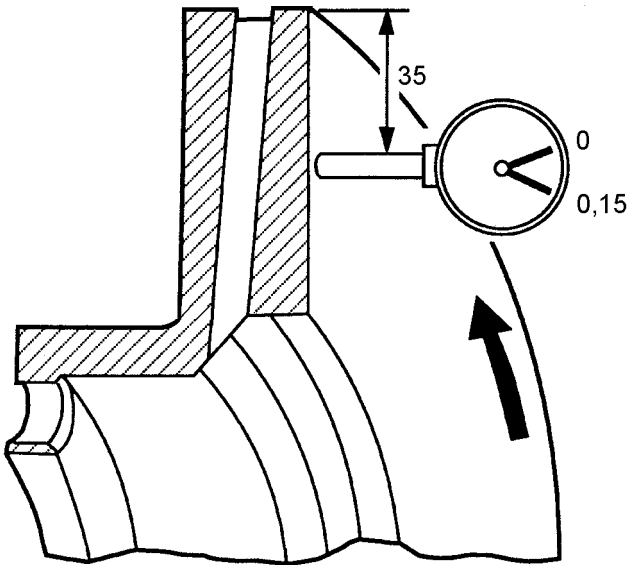

- Replace the brake disc or have it properly reworked if the brake disc runout is more than 0.15 mm.
- Install the brake linings, and adjust the clearance (see chapter 4.3 „Fitting the brake linings“, page 17).

3.3.3 Checking the bearing play of the guide pin

- Remove the vehicle wheel.
In this respect, please note the instructions and regulations of the axle or vehicle manufacturer.
- Remove the brake linings and the pressure plate (see chapter 4 „Replacing the brake linings“, page 13).

! The measuring point is always the moulded edge on the brake calliper on the rim side (see arrow in the figure below).

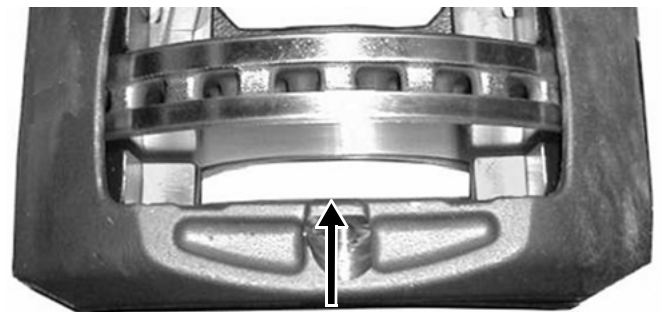

- Clean the measuring point before measuring.
- Move the calliper completely to the rim side by hand.
- Fasten the magnetic dial indicator support to the brake carrier or the axle.
- Press the dial indicator against the measuring point (see figure below).



- Use minimal manual force to tilt the brake calliper as far as possible into the radial direction and set the dial indicator to zero.

- Read off the maximum bearing play from the dial indicator.
The measured bearing play must not exceed 2.0 mm.
If the measured value is greater, replace the components (see chapter 6.1 „Renewing the protection caps and the bushings of the guide pins“, page 23).

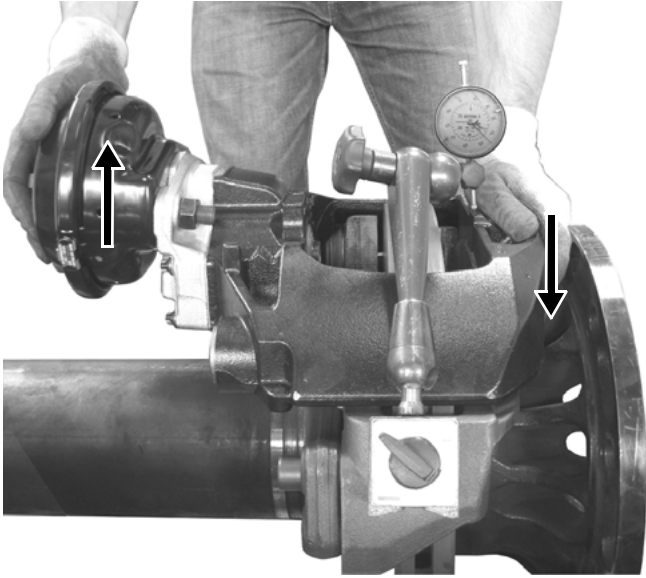

- Remove the measurement device.
- Install the pressure plate and brake linings, and adjust the clearance.
Observe the work step sequence and other instructions (see chapter 4 „Replacing the brake linings“, page 13).
- Install the vehicle wheel.
In this respect, please note the instructions and regulations of the axle or vehicle manufacturer.

4 Replacing the brake linings



CAUTION! Risk of injury

- Observe all safety, repair and maintenance instructions (see chapter 1 „Important instructions and safety instructions“, page 3).
- These instructions must be observed to avoid personal injury and/or material damage.

! The brake cylinder does not need to be dismantled in order to replace the brake linings. The brake is shown without the brake cylinder for illustration purposes only.

Always replace the brake linings by axle and use a new retaining system for brake linings and pressure plates.

4.1 Removing the brake linings

! The cable routing or the fastening of these cables on the brake may vary, depending on the brake design. Here only a particular case of application is described. It is therefore essential for the subsequent installation of a new system to note the original position of the fastening elements prior to removal.

- Remove the vehicle wheel. In this respect, please note the instructions and regulations of the axle or vehicle manufacturer.
- Disconnect the plug connection (see arrow in the figure below) of the wear indicators (40).

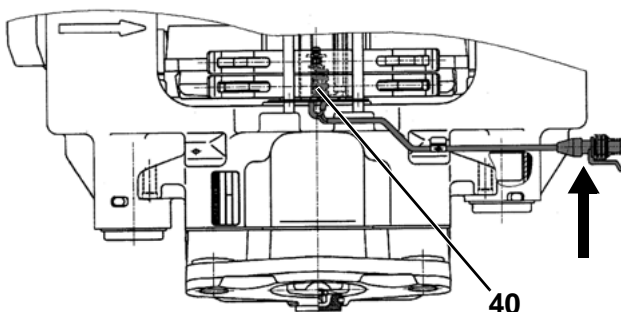

- Remove the hexagon head screw (39) from the lining retainer (38) (see chapter 8.2 „Widths across flats and tightening torques“, page 37, item II).

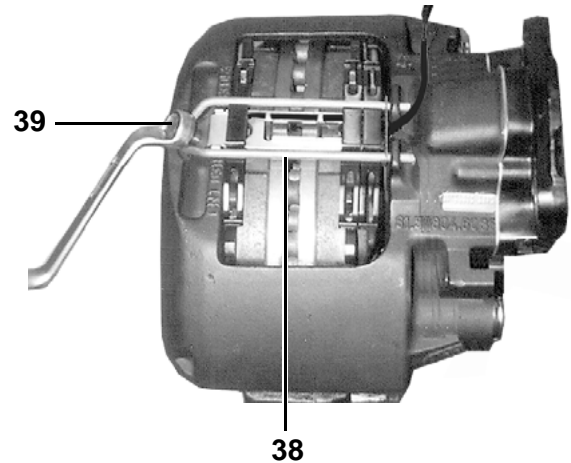

- The lining retainer (38) has to be withdrawn from the calliper (1).
- Remove three hold-down springs (37) from the brake linings (35 and 36) and the pressure plate (19).

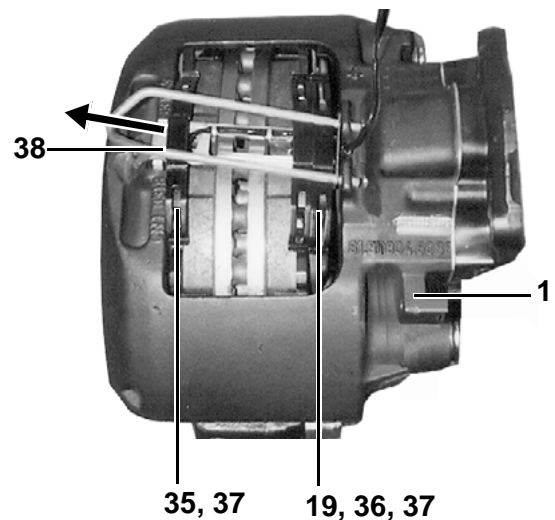

- Remove the cable guide (40) with the wear indicators.
- Remove the cable clips (41) from the calliper.

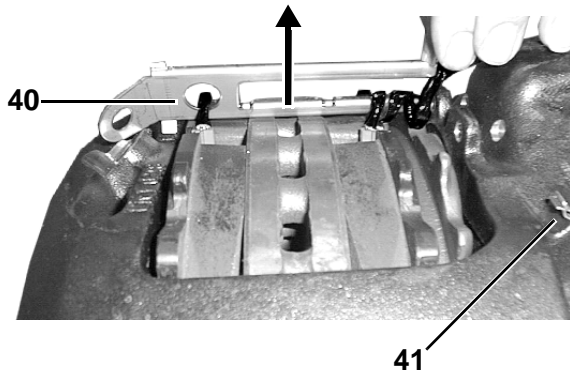

- Carefully remove the sealing plug (12) of the adjuster (22).

! When removing the sealing plug, apply the respective tool (such as a screwdriver) only to the sealing plug and do not damage the closing cover (13) or the brake calliper.

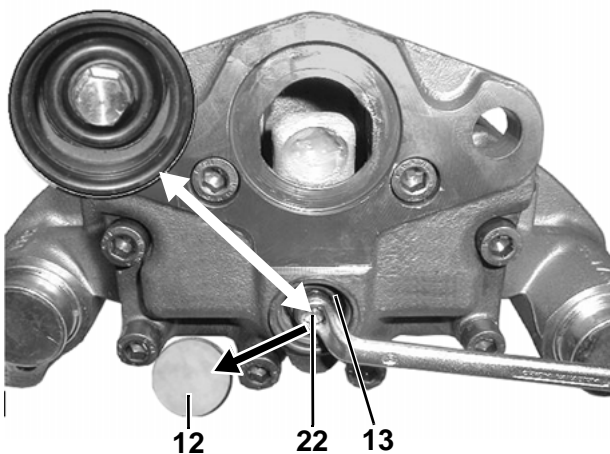

- Check the protection cap (13) for wear and damage.
- If the protection cap (13) of the adjuster is defective, replace it (see chapter 6.2 „Renewing the protection cap of the adjuster screw“, page 28).
- Turn the hexagon (22) of the adjuster clockwise with a ring spanner (tools 12 and 13) up to the stop position.
- Then turn the hexagon back anticlockwise by approx. 90°.

- While turning the hexagon (22), use your hand to push the pressure plate (19) towards the cylinder side to ensure that the pin as an antirotation lock for the adjuster screw (21) does not slip out of the retaining groove of the pressure plate. Otherwise there is a risk of the adjuster screw turning simultaneously, which could damage the protection cap (10).
- Push the calliper (1) towards the rim side by hand (see arrow in the figure below).
- Remove the brake lining (35) on the rim side.

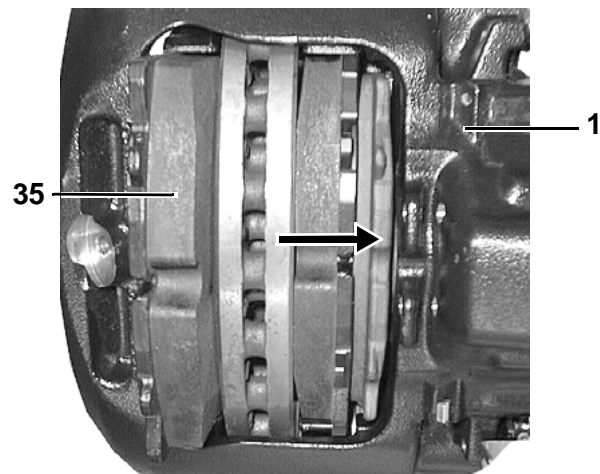

- Push the calliper (1) towards the cylinder side by hand (see arrow in the figure below).
- Remove the brake lining (36) and pressure plate (19) on the cylinder side.

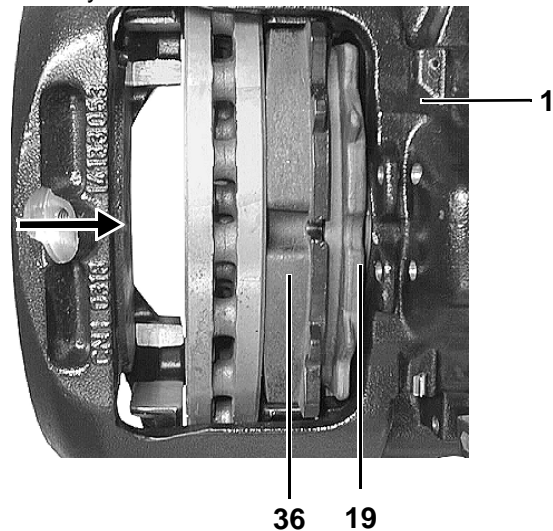

WARNING!

Risk of accident due to brake actuation with brake lining removed

- Never apply the brake when brake linings have been removed.

- Check the pressure plate (19) for corrosion and damage.
- Renew the pressure plate if you have identified damage.
Always replace the pressure plate axle by axle.
- Use a wire brush to clean pressure plate, lining slots and pressure plate guide, and remove any corrosion on these components.



CAUTION!
Damage to the protection caps due to cleaning

- Make sure that you do not damage the protection caps (5, 10) when cleaning.

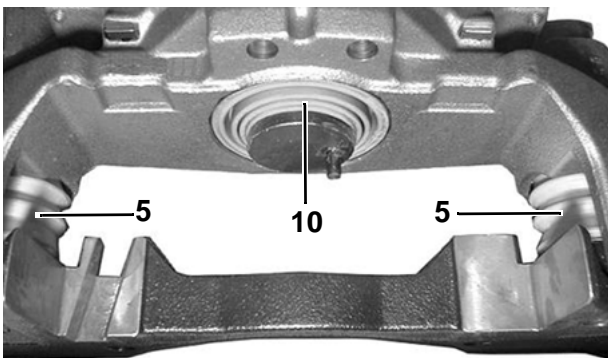

! The guide surfaces of the brake linings on the brake anchor plate must be clean and free of grease.

4.2 Checking the protection caps and the ability of the brake calliper to move

- Push the calliper (1) towards the cylinder side (see arrow in the figure below).
- Check the protection caps (5, 10) for the guide pins (8, 9) and the adjuster screw (21) for wear and damage.
- Replace the defective protection caps (see chapter 6.1 „Renewing the protection caps and the bushings of the guide pins“, page 23 and see chapter 6.2 „Renewing the protection cap of the adjuster screw“, page 28).

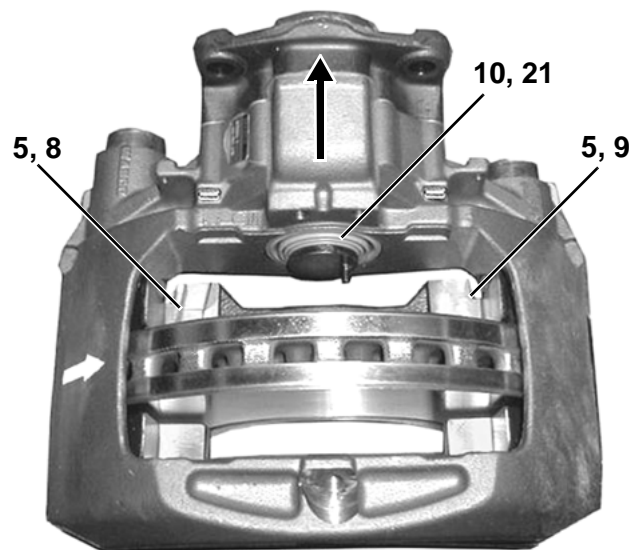

! If the protection cap (10) is damaged, check whether dirt or moisture has penetrated into the brake's interior parts or have damaged the calliper due to corrosion.
Renew the brake if you have identified damage or corrosion (see chapter 5 „Renewing the brake“, page 20).
Renew the protection caps if they are damaged during service work on the brake.

- Manually move the brake calliper on the guide pins across the entire displacement path and check for ease of movement.

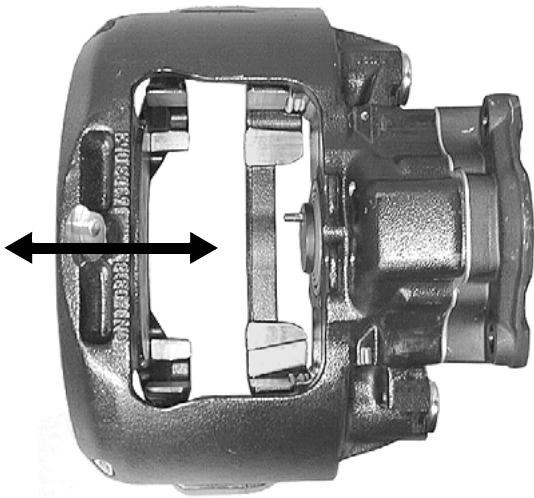

! Do not squeeze the guide pin protection caps against the brake anchor plate while moving the calliper.

- Replace the bushings and the protection caps if the calliper moves sluggishly (see chapter 6.1 „Renewing the protection caps and the bushings of the guide pins“, page 23).
- Manually check the adjuster.
- Secure the adjuster screw (21) against twisting when performing the test and when turning the hexagon (22) by arresting the pin (see arrow in the figure below) of the adjuster screw.

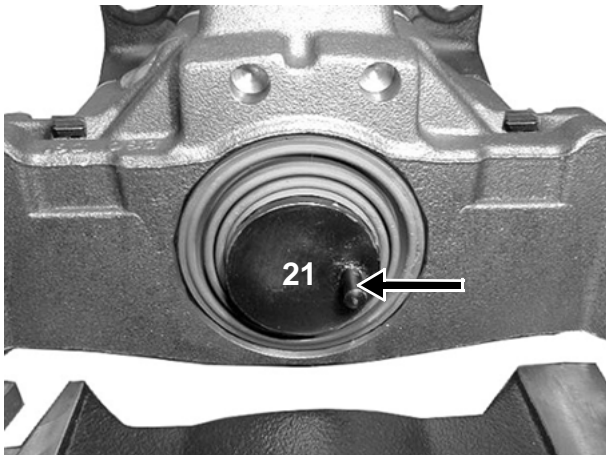

- Use the ring spanner (tools 12 and 13) to turn the hexagon nut of the adjuster (22) clockwise until the adjuster screw (21) is out about 30 mm.
- Check for ease of movement when doing this.



WARNING!

Damage to the hexagon due to overstraining

- Do not use an open-end spanner for the hexagon (22) of the adjuster and never overstrain the hexagon nut.
- Use the ring spanner to turn the hexagon (22) clockwise back to the stop. When turning back (clockwise) the torque is greater than when turning anticlockwise.



- If necessary, check the function of the adjuster (see chapter 3.1 „Checking the automatic adjuster“, page 8).

4.3 Fitting the brake linings

- To insert the pressure plate and the brake linings on the cylinder side, push the calliper towards the cylinder side until there is sufficient distance to the brake disc.
- Insert the pressure plate (19) into the brake anchor plate and push the pressure plate against the adjuster screw (21).

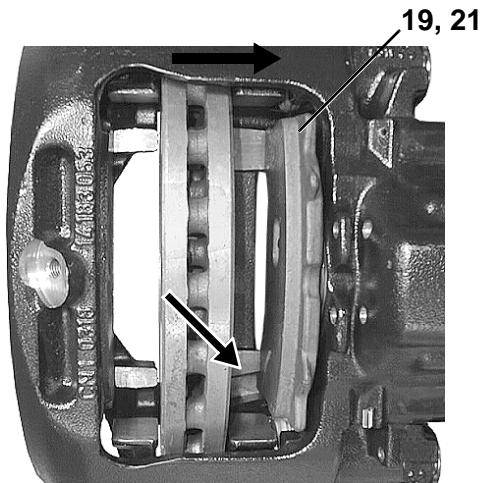

- Push the calliper towards the rim side until the brake lining (36) of the cylinder side bears against the brake disc.

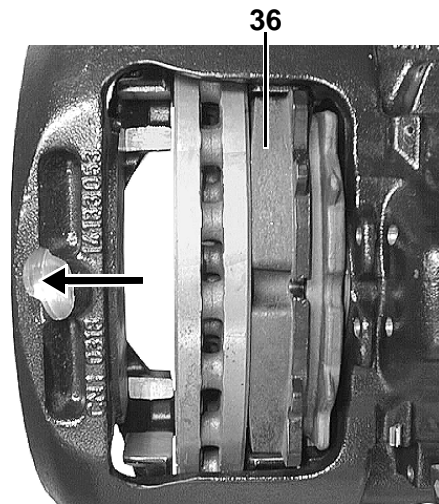

- Fit a **new** brake lining (35) on the rim side.

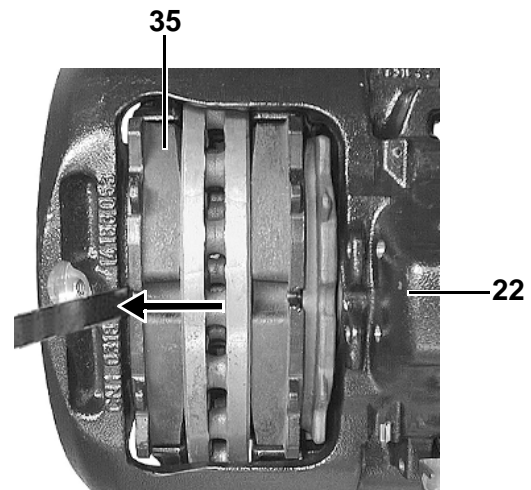

! Ensure that the pressure plate is seated in the guide groove of the brake anchor plate (small arrow in the figure above) and that it rests with the entire surface on the guide strips of the brake anchor plate. Otherwise the pressure plate could slide out of the guiding.

If required, push the calliper a little towards the rim side.

The pin of the adjuster screw must mesh with the groove of the pressure plate, otherwise the adjustment will not function.

Turn the adjuster screw until the pin meshes with the groove of the pressure plate. Ensure that the protection cap is not twisted.

- Adjust the clearance by means of a 1 mm feeler gauge (arrow). For this purpose insert the feeler gauge between the brake lining of the rim side and the calliper. Turn the hexagon (22) of the adjuster anticlockwise with a ring spanner (tools 12 and 13) until both brake linings bear on the brake disc.

! Always insert the feeler gauge into the centre between brake calliper (1) and brake lining support plate (35).

Do not use an open-end spanner for the hexagon (22) of the adjuster and never overstrain the hexagon nut. Otherwise the hexagon will be damaged.

- Fit a **new** brake lining (36) on the cylinder side.

Mount the lining retainer pin only **after** you have adjusted the clearance.

- Remove the feeler gauge again.

! Ensure that each wear side of the indicators points towards the brake disc and that the indicators are inserted completely into the brake lining.

- Position the cable guide plate (40) and the cable outlet of the wear indicators onto the brake calliper.

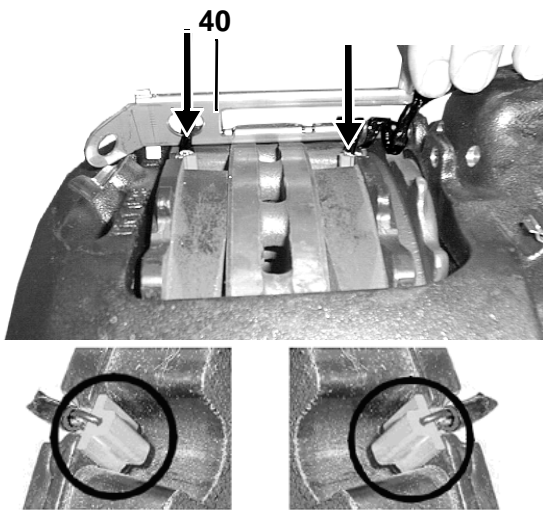

! When laying the cable, ensure that the cable does not touch the brake lining.

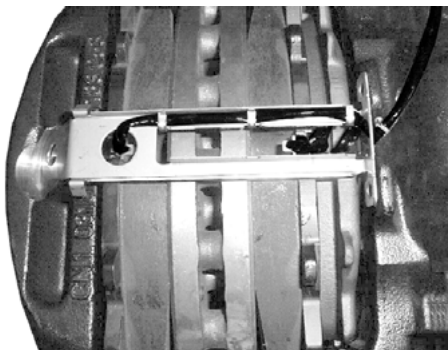

- Place **three new** retaining springs (37) over the cable guide plate (40) onto the brake linings (35, 36) and the pressure plate (19).

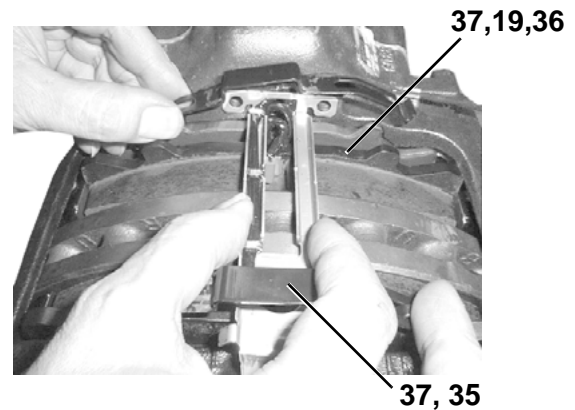

- Push the **new** lining retainers (38) through the openings in the cable guide into the openings of the brake calliper.

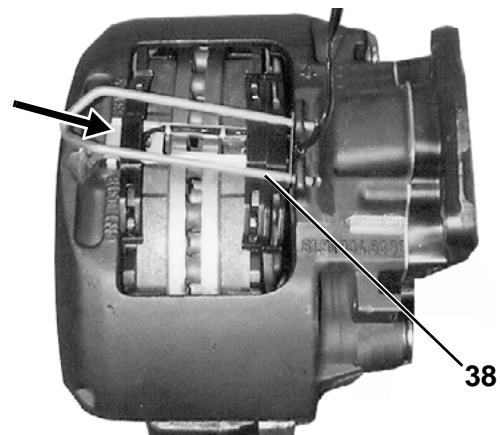

- Press down the lining retainer so that the radial lugs of the hold-down springs mesh with the retainer.
- Fasten one **new** hexagon head screw (39) to the brake calliper (see chapter 8.2 „Widths across flats and tightening torques“, page 37, item II).

- If installed, remove the transport protection cap (see arrow in figure below) from the wear indicator connectors.

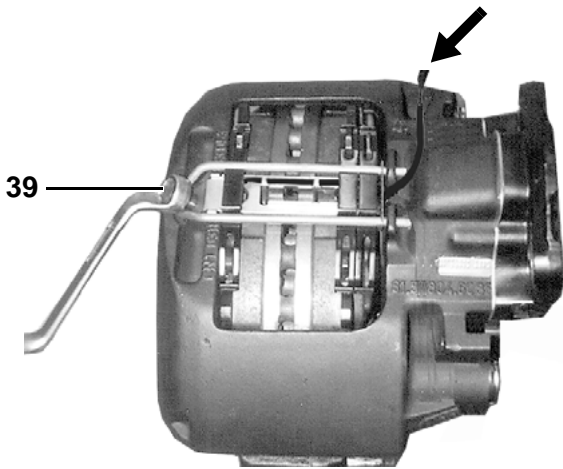

- Insert a **new** cable clip (41) into the brake calliper and place the cable into it.
- Fasten the cable outlet on the new cable clip (41).
- Plug the wear indicator connector into the plug coupling (see arrow in the figure below).

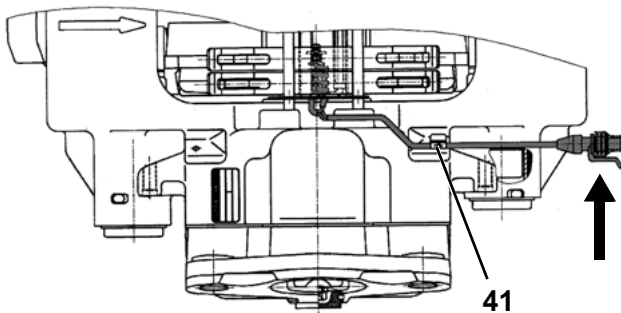

- Push a **new** sealing plug (12) into the opening of the brake calliper. Ensure that the plug has a tight seat.

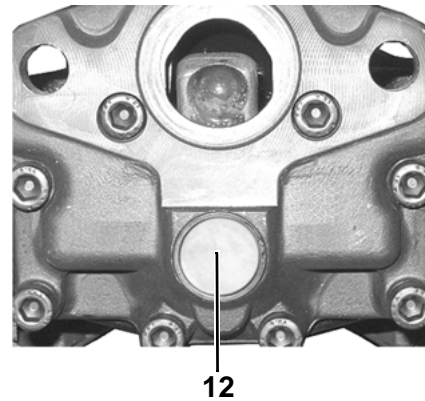

- Check the wheel hub for ease of movement.
- Install the vehicle wheel. In this respect, please note the instructions and regulations of the axle or vehicle manufacturer.

! Having completed the work, test the brake on a roller test stand.

5 Renewing the brake



CAUTION!

- Observe all safety, repair and maintenance instructions (see chapter 1 „Important instructions and safety instructions“, page 3).
- These instructions must be observed to avoid personal injury and/or material damage.

! Never use the lining retainer (38) as a grab handle or for fastening the brake to a lifting device, because the retainer can be damaged in the process.

The **new** brake (without linings) is supplied as a pre-assembled unit and may be mounted to the vehicle's axle via the brake carrier.

Do not interchange the left brake (figure A) and the right brake (figure B) on the axle. The correct assignment of the brakes to left and right side of the axle can be determined by means of the brake's lining retainer (38) and hexagon screw (39) positions.

The following pattern applies in this respect: The retention aperture for the lining retainer (38) and the thread opening for the hexagon screw (39) in the calliper are always offset relative to the brake centre M (axle) by an axle offset V in the brake disc exit direction (brake disc direction of rotation driving forward).

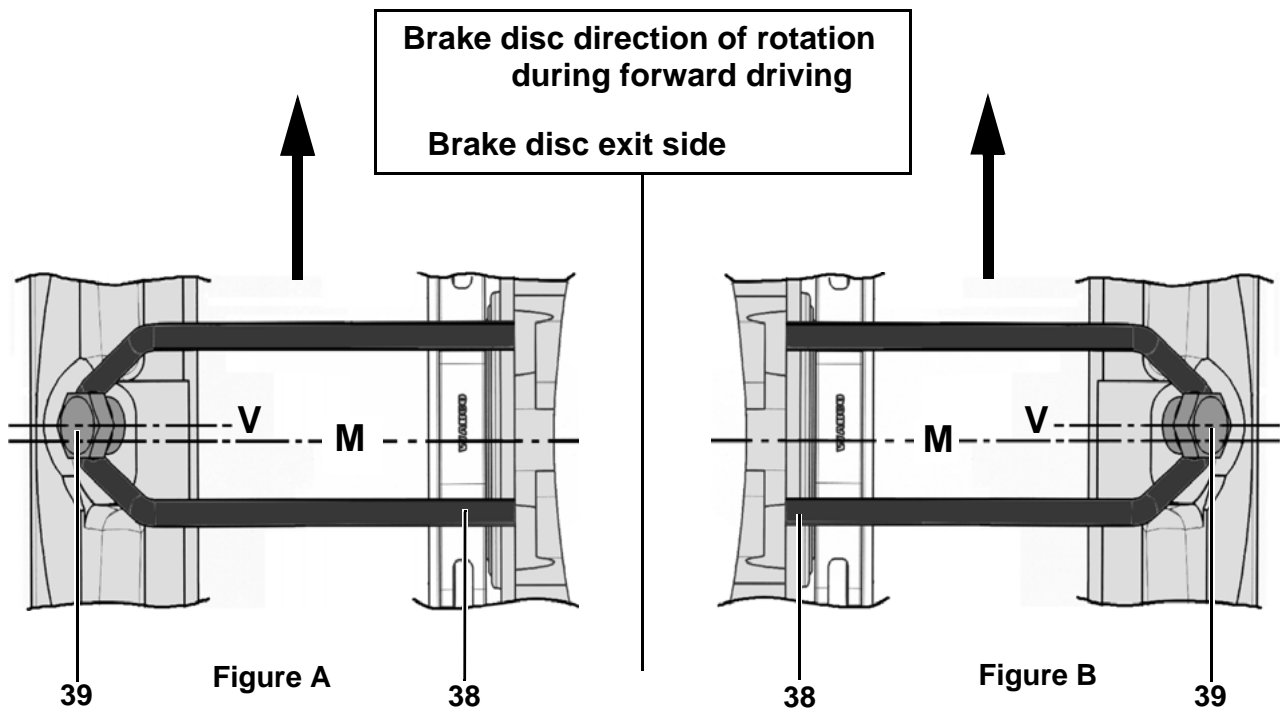

5.1 Removing the brake

! The illustrations of the brake anchor plate are for example only and may deviate from the actual brake design.

- Remove the vehicle wheel.
In this respect, please note the instructions and regulations of the axle or vehicle manufacturer.
- Disconnect the plug connection of the wear indicators.

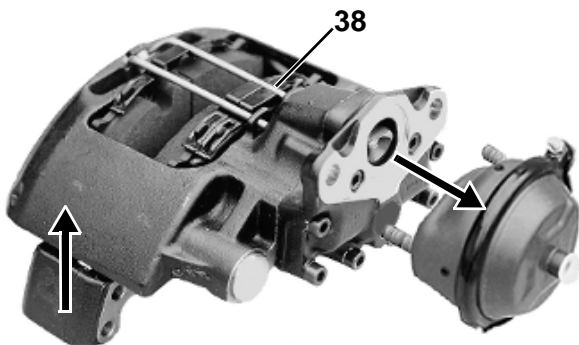

- Remove the brake linings (see chapter 4.1 „Removing the brake linings“, page 13).
- Remove the brake cylinder from the brake calliper (see chapter 7.1 „Removing the brake cylinder“, page 33).
- Remove the brake calliper with brake anchor plate from the axle (see chapter 8.2 „Widths across flats and tightening torques“, page 37, table, item III).
- Inspect the brake disc (see chapter 3.3 „Inspecting the brake discs“, page 10).
- Check the dismantled brake linings and replace if necessary (see chapter 3.2 „Checking the brake linings“, page 9).
- Check the fastening flange on the axle for wear and damage.
- Clean the fastening flange on the axle and remove any dirt, rust and grease.

5.2 Installing the brake

! When installing the brake, please note the instructions and regulations of the axle or vehicle manufacturer.

Make sure you do not interchange the right and left brake.

- Place the brake with brake carrier over the brake disc and mount the brake to the axle.
- Tighten the hexagon head screws (see chapter 8.2 „Widths across flats and tightening torques“, page 37, item III).
In this respect, please note the instructions and regulations of the axle or vehicle manufacturer.

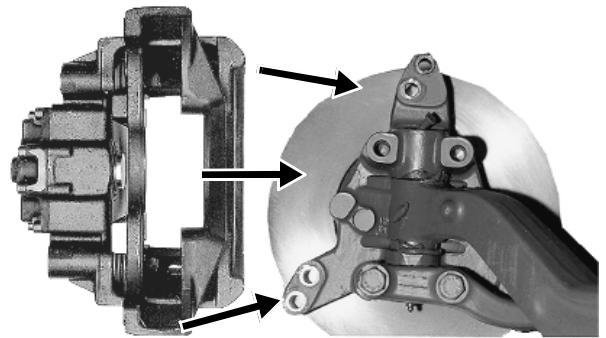

- Remove **all** the transport fastenings from the **new** brake.
- Before installing the cylinder, completely remove the transport protection as cap or protective film in the area of the brake cylinder fastener.

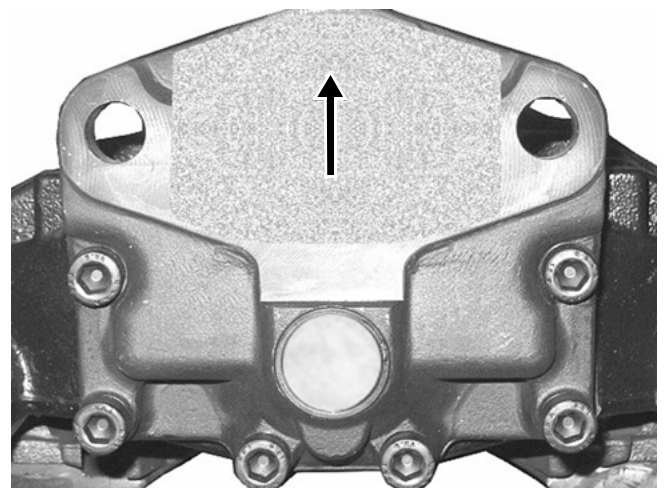

- Install the brake linings.
- Set the clearance.
- Prior to installation, inspect the brake cylinder for damage, particularly at the inner area of the piston-rod seal.

! Renew the brake cylinder if you have identified damage.
 ■ A defective brake cylinder must not be fitted again.

- Clean the sealing surface and the flange area of the brake cylinder.
- Mount the brake cylinder on the calliper(see chapter 7.2 „Installing the brake cylinder“, page 33).

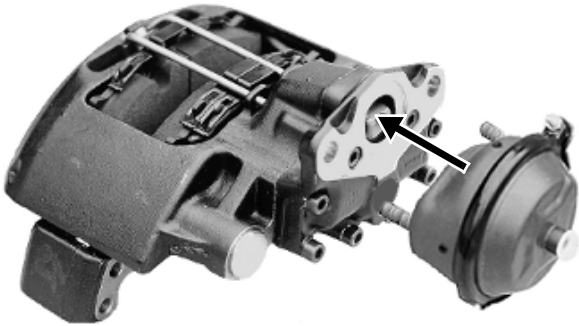

! Depending on the installation position of the brake, ensure that the lower drainage aperture of the brake cylinder facing the ground is open.

Depending on the actuator type, the other drainage openings can either remain open or they must be sealed with a plug. Observe the respective instructions of the brake cylinder manufacturer.

- Check whether the wheel hub moves freely.
- Install the vehicle wheel.
 In this respect, please note the instructions and regulations of the axle or vehicle manufacturer.

! Having completed the work, test the brake on a roller test stand.

6 Renewing the seals



CAUTION! Risk of injury

- Observe all safety, repair and maintenance instructions (see chapter 1 „Important instructions and safety instructions“, page 3).
- These instructions must be observed to avoid personal injury and/or material damage.



CAUTION! Damage to the retainer due to incorrect use

- Never use the lining retainer (38) as a grab handle or for fastening the brake to a lifting device.

! If all seals of the brake calliper are replaced, the work sequences for renewing the protection caps and bushings of the guide pins, as well as the protection cap of the adjuster screw can be performed together.

If the seals were individually replaced however, the step sequences are to be performed individually as described in the respective sections (Kapitel 6.1 and Kapitel 6.2).

The illustrations are for example only and may deviate from the actual design.

6.1 Renewing the protection caps and the bushings of the guide pins

! The guide pin's position in the brake may vary, depending on the particular case of application. This illustration shows an installation example with a long guide pin (8, fit bolt) while driving forward on the brake disc entry side. A replacement can also be carried out with a short guide pin (9, play bolt) at the brake disc entry side.

6.1.1 Disassembly

- Remove the vehicle wheel.
In this respect, please note the instructions and regulations of the axle or vehicle manufacturer.
- Disconnect the plug connection of the wear indicators.
- Remove the brake linings (see chapter 4.1 „Removing the brake linings“, page 13).

- Remove the brake cylinder from the brake calliper (see chapter 7.1 „Removing the brake cylinder“, page 33).
- Remove the brake calliper with brake anchor plate from the axle (see chapter 8.2 „Widths across flats and tightening torques“, page 37, table, item III).

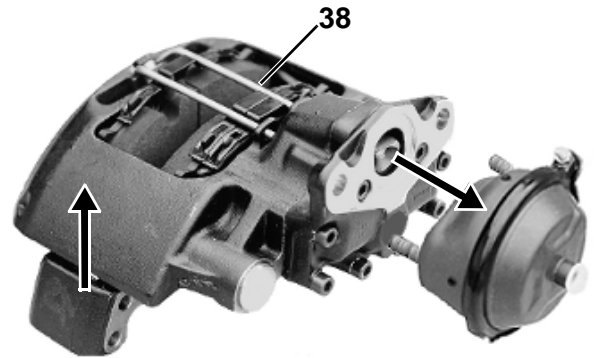

- Use a suitable fastening device (e.g. a vice) to clamp the brake to the brake carrier.
- Remove the sealing plug (11) of the pin guide (8, 9) from the brake calliper (1).

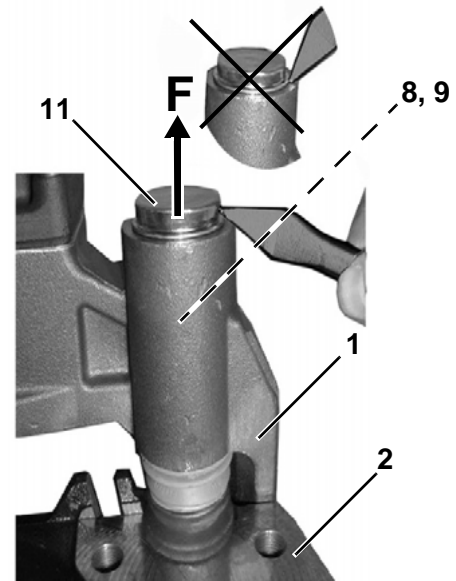

CAUTION! Damage to the bore due to tools

- When removing the sealing plug, apply the respective tool (such as a chisel) only to the closing cover so that the holes of the closing cover on the brake calliper can not be damaged.

- Unscrew the screws (6, 7) (see chapter 8.2 „Widths across flats and tightening torques“, page 37, table, item IV).
- Remove the brake calliper (1) from the brake carrier (2).

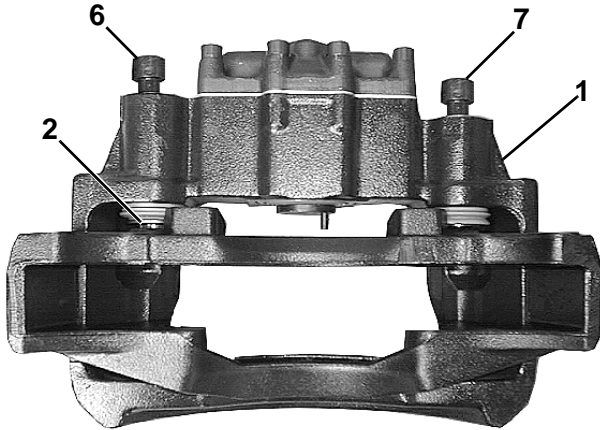

CAUTION!
Risk of injury due to unsecured brake calliper

- Make sure that the loose brake calliper does not squash your fingers.
- Clean the contact areas (fitting collars) to the guide pins on the brake carrier (2).
- Remove the guide pins (8, 9) from the brake calliper (1).
- Pull the protection cap (5) out of the ring groove of the brake calliper (1).

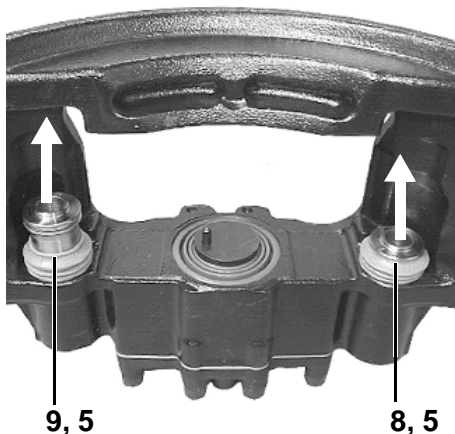

- Place the brake calliper (1) on a firm base for pressing out the bushings (4). The cover opening of the brake calliper must face upwards.

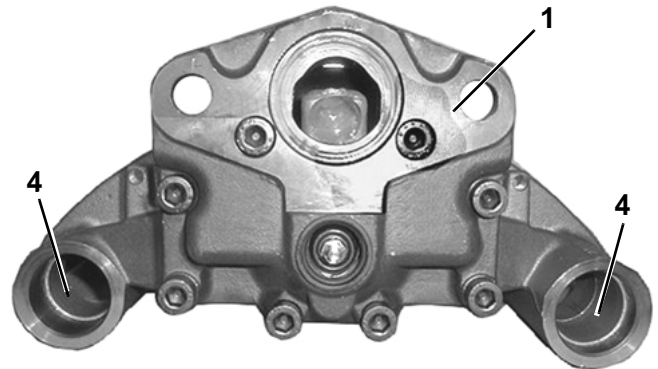

- Use WABCO tools (see chapter 8.1 „WABCO tools“, page 36) to replace the bushings.

- Press the bushings (4) out of the brake calliper (1) using tools 10, 11 and 14.

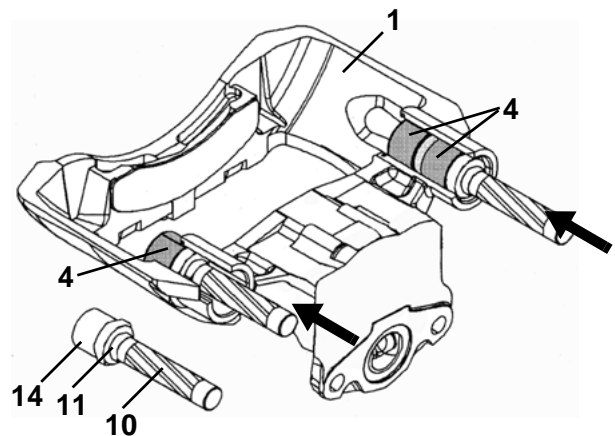

- Clean the bores in the calliper.

6.1.2 Assembly

- Press in two **new** bushings for the long guide pin.
- First use tools **10**, **11** and **16** to press in the inner bushing up the stop position of the tool.

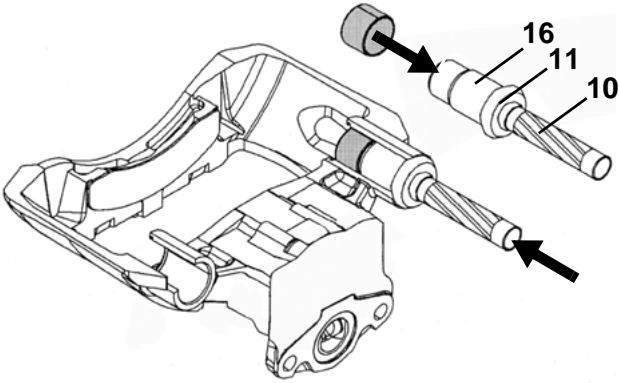

- Then use tools **10**, **11** and **15** to press in the outer bushing up to end stop of the tool.
- Grease the sliding surfaces of the bushings and the space between them.

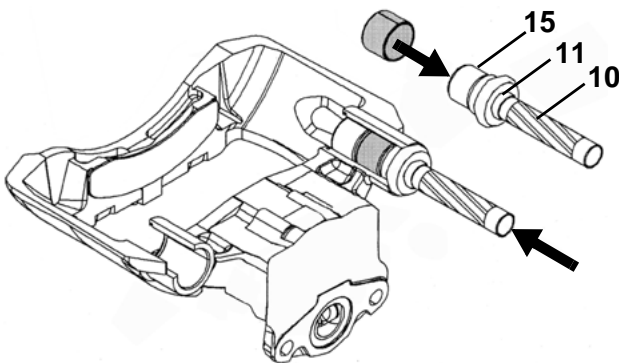

- Use tools **10**, **11** and **17** to press a **new** bushing (4) for the short guide pins into the bore on the brake disc exit side of the brake calliper (1) to the end stop of the tool.
- Grease the sliding surface of the bushing.

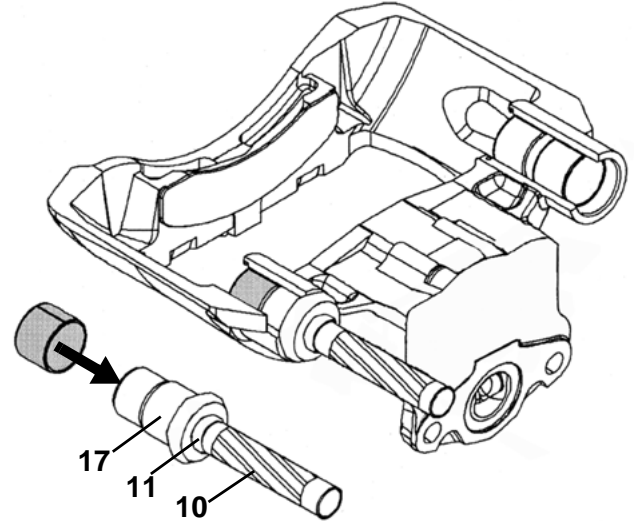

- Clean the sealing seats (ring groove) of the brake calliper for the protection caps.

! The cleaned sealing seats must be clean and free of grease.

- Press **new** green protection caps (5) by hand into the seal seats (ring groove, arrow) of the brake calliper (1).

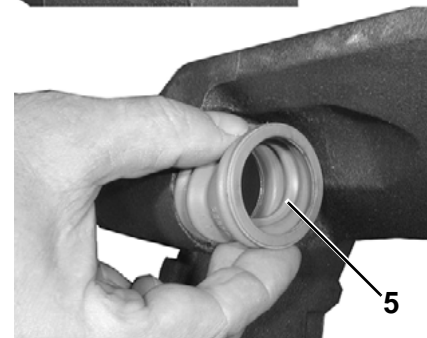
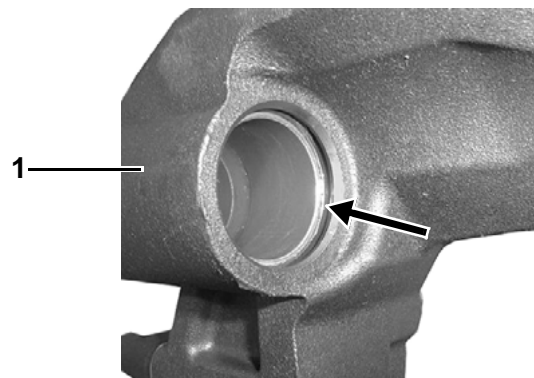

Make sure that the protection caps (5) have an even and wrinkle-free seat in the seal seat of the brake calliper (1).

- Grease the bearing surfaces of the guide pins (8, 9) and the beaded edge of the protection caps (5).
- Insert a **new** long guide pin (8) from the cylinder side into the brake calliper (entry side of the brake disc).
- Slide the protection caps (5) over both guide pins.
- Position the beaded edge of the protection caps (5) into the sealing seats (ring grooves) of the guide pins (8, 9).

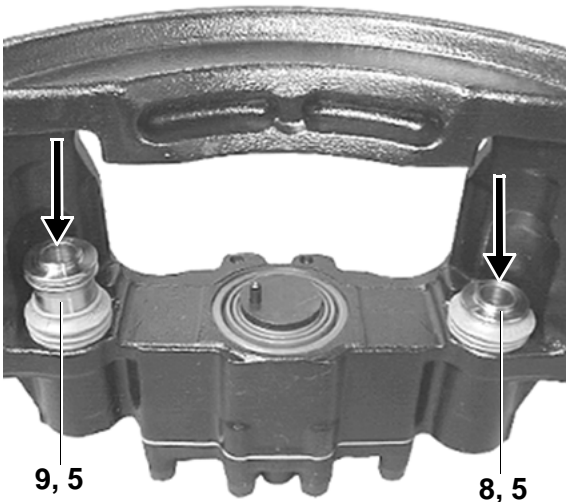

Ensure that the protection caps (5) have an even and crease-free seat in the sealing seats of the guide pins (8, 9).

- Remove any excess grease.

The plane surfaces of the guide pins to the brake carrier and the contact areas of the brake carrier must be clean and free of grease.

- Manually move the guide pins in the bushings lightly back and forth and check for ease of movement.
- Place the calliper (1) on the brake carrier (2) and the inserted guide pins (8, 9) into the fitting collar.

- Insert two **new** screws (6, 7) through the guide pins inserted in the brake calliper (1).
Long screw (6) for fit bolt (8)
Short screw (7) for play bolt (9)

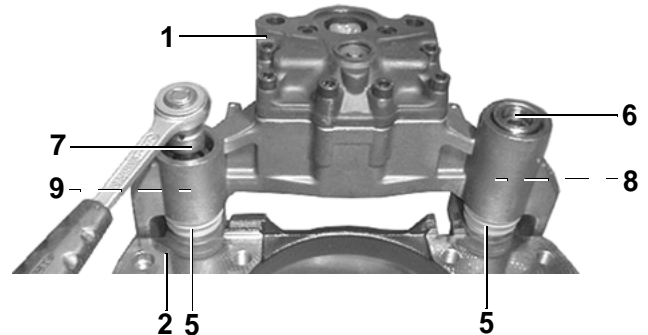

- Fasten the screws to the brake carrier (2) (see chapter 8.2 „Widths across flats and tightening torques“, page 37, table, item IV).

During assembly, ensure that the protection caps (5) are not damaged or twisted while tightening the screws (6, 7).

Always tighten the longer guide pin (8) with press-fit first and then the shorter guide pin (9) with clearance.

If the guide pins (8, 9) are released from the brake anchor plate (2) during the maintenance work, **new** screws (6, 7) must be used for reassembly.

- Manually move the brake calliper on the guide pins (8, 9) across the entire displacement path and check for ease of movement; repeat the action a number of times.

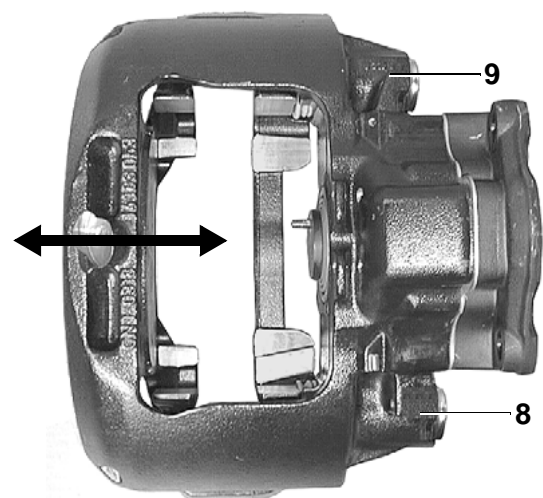

! Do not squeeze the guide pin protection caps against the brake carrier while moving the calliper.

- Grease the bores for the closing cover (11) in the brake calliper (1).
- Push the brake calliper (1) against the brake carrier.
- Insert the **new** closing covers (11) into the bores of the brake calliper (1).
- Press in the closing covers up to the stop using tools 10, 11 and 18.



CAUTION!
Damage to covers when pressing in

- Use care when pressing in the covers to avoid damage.

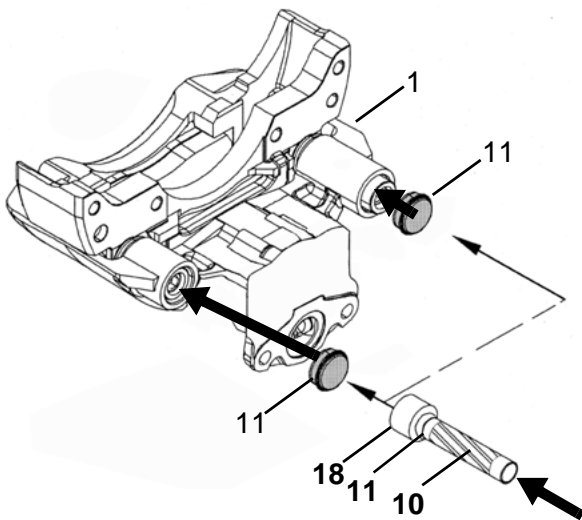

- Carefully lift the protection caps (5) in the ring groove area to equalise the pressure and then reinsert them.

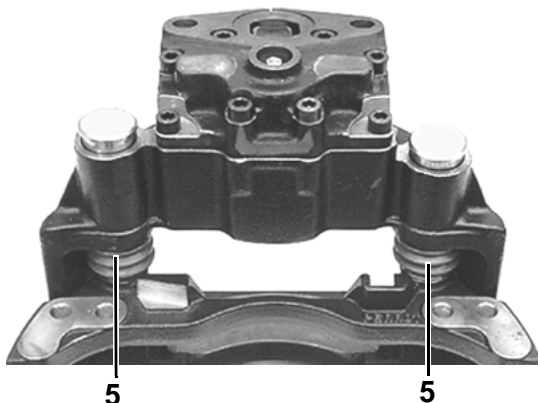

- Check the connecting surface on the fastening flange of the axle and the brake carrier.
- Remove any dirt, rust or oil.
- Place the brake with brake carrier over the brake disc.

- Install the brake on the axle. (see chapter 5.2 „Installing the brake“, page 21). In this respect, please note the instructions and regulations of the axle or vehicle manufacturer.

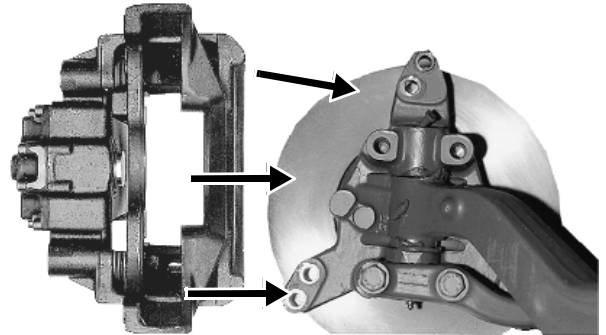

- Install the brake linings, and adjust the clearance (see chapter 4.3 „Fitting the brake linings“, page 17).
- Clean the sealing surface and the flange area of the brake calliper.
- Grease the calotte (see vertical arrow in the figure below) in the brake lever.

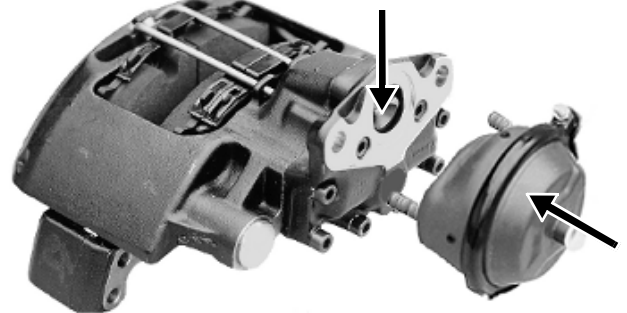

- ! Ensure that no dirt or moisture enters the brake when cleaning.

- Check the brake cylinder for damage, particularly at the inner area of the piston-rod seal.

- ! Renew the brake cylinder if you have identified damage. A defective brake cylinder must not be fitted again.

- Clean the sealing surface and the flange area of the brake cylinder.

- Mount the brake cylinder on the calliper(see chapter 7.2 „Installing the brake cylinder“, page 33). In this respect, please note the instructions and regulations of the axle or vehicle manufacturer.

! Depending on the installation position of the brake, ensure that the lower drainage aperture of the brake cylinder facing the ground is open. Depending on the actuator type, the other drainage openings can either remain open or they must be sealed with a plug. Observe the respective instructions of the brake cylinder manufacturer.

- Check whether the wheel hub moves freely.
- Install the vehicle wheel. In this respect, please note the instructions and regulations of the axle or vehicle manufacturer.

! Having completed the work, test the brake on a roller test stand.

6.2 Renewing the protection cap of the adjuster screw

! If the protection caps are removed individually, brake calliper and brake cylinder need not be dismantled.

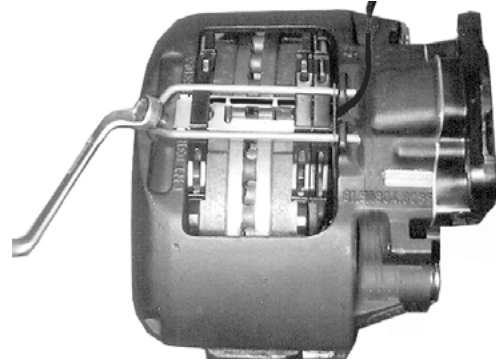

6.2.1 Removing the protection cap

- Remove the brake linings and the pressure plate (see chapter 4.1 „Removing the brake linings“, page 13).
- Push the calliper completely to the cylinder side by hand.
- Pull the protection cap (10) from the sealing seat (ring groove) of the adjuster screw (21).
- Remove the protection cap (10) from the sealing seat of the brake calliper with a screwdriver.



CAUTION!
Damage to the sealing seat due to screwdriver

- Carefully remove the protection cap to avoid damaging the sealing seat.



- Check the brake calliper. If dirt or moisture has entered the brake, or if the sealing seat in the brake calliper or the thread of the adjuster screw (21) is damaged, replace the brake (see chapter 5 „Renewing the brake“, page 20).

- Fit the rim side brake lining into the lining slot so that the adjuster screw cannot be screwed out of the adjuster completely.
- Secure the adjuster screw (21) on the pin against twisting.

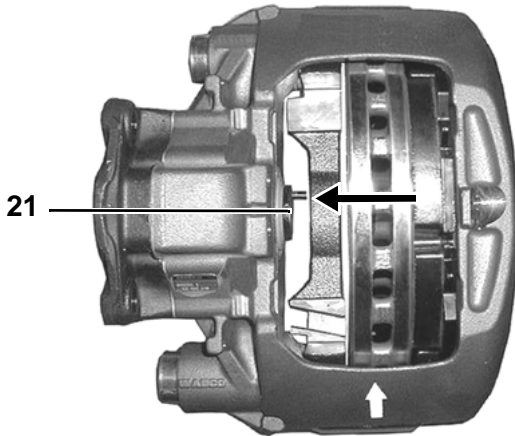

- Use tools 12 and 13 to turn the hexagon (22) in anticlockwise direction until the adjuster screw has been backed off by approx. 30 mm (see chapter 8.2 „Widths across flats and tightening torques“, page 37, item I).
- While threading it out, check the thread of the adjuster screw (21) for corrosion and damage. If the thread and/or visible internal brake parts are damaged or corroded, replace the brake (see chapter 5 „Renewing the brake“, page 20).

! The protection cap (10) can be renewed, if definitely no dirt or water has penetrated into the brake calliper, or if the protection cap has been damaged directly in the process of servicing the brake.

- Clean the sealing seats (see arrows in the figure below) of the protection cap (10) in the brake calliper and the ring groove of the adjuster screw (21).

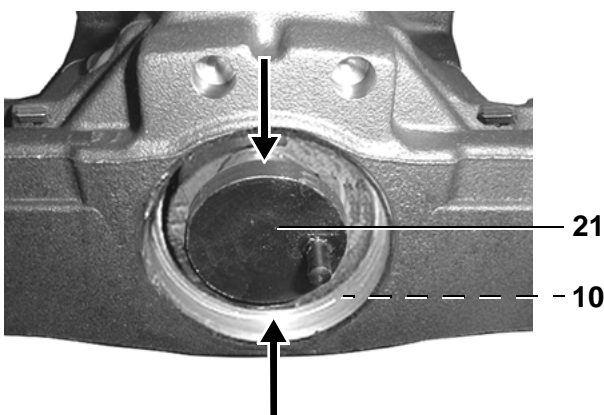

! Ensure that no dirt or moisture enters the brake when cleaning.

The sealing seat for protection cap (10) in the brake calliper must be clean and free from grease.

- Grease the thread of the adjuster screw (21).
- Use a ring spanner to turn the hexagon (22) anticlockwise until the adjuster screw has been partially turned inwards again through this action. The adjuster screw pin must be in the same position as it was before it was screwed out.

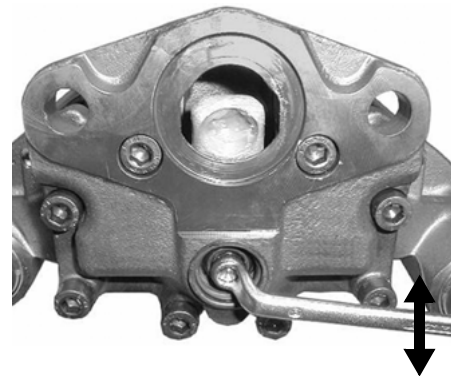

- Remove the brake lining from the lining slot on the rim side.

6.2.2 Fitting the protection cap

- Push a **new and grease-free** protection cap (10) over the adjuster screw.
- Centre the protection cap.
- Manually push the new protection cap into the sealing seat of the brake calliper (1).
- Lightly grease the inner beaded edge of the protection cap (10).
- Insert the protection cap (10) into the sealing seat of the adjuster screw (21).
Ensure that the cap has a correct sealing seat in the brake calliper (1) and that the beaded edge of the protection cap (10) has an even and wrinkle-free seat in the ring groove of the adjuster screw (21).

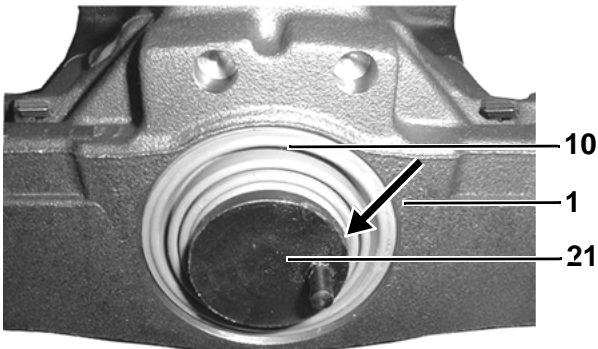

- Install the pressure plate and brake linings.
- Set the clearance (see chapter 4.3 „Fitting the brake linings“, page 17).

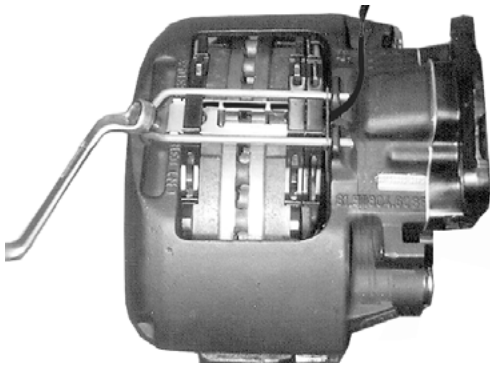

6.3 Renewing the protection cap of the adjuster screw

! If the protection caps are removed individually, brake calliper and brake cylinder need not be dismantled.

6.3.1 Fitting the protection cap

- Carefully remove the sealing plug (12) of the adjuster (22).

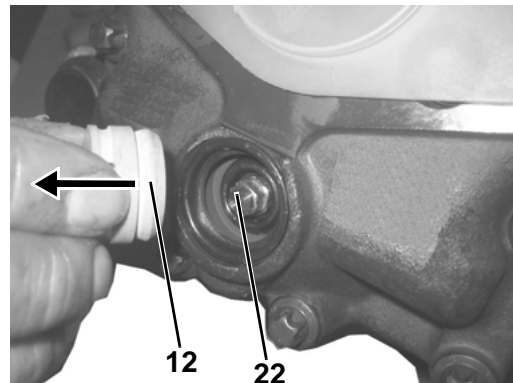

- Use a suitable tool (e.g. screwdriver) to press the protection cap (13) out of the brake calliper seat.

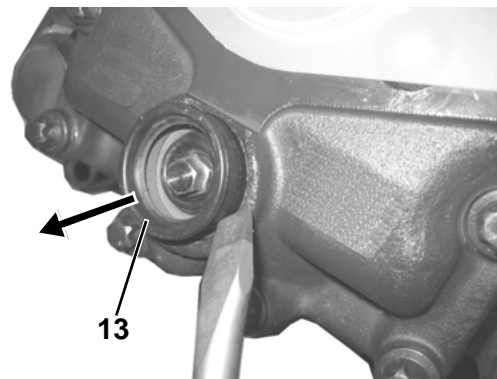

- Remove the protection cap from the hexagon of the adjuster.
- Clean the seats of the protection cap in the brake calliper.

! Ensure that no dirt or water enters the brake when cleaning.

The protection cap (13) can be renewed, if definitely no dirt or water has penetrated into the brake calliper, or if the protection cap has been damaged directly in the process of servicing the brake. If in doubt,

replace the brake should there be corroding parts, see chapter 5 „Renewing the brake“, page 20.



- Place the mounting cap (A) onto the hexagon of the adjuster (22) and push it right up to the stop position.

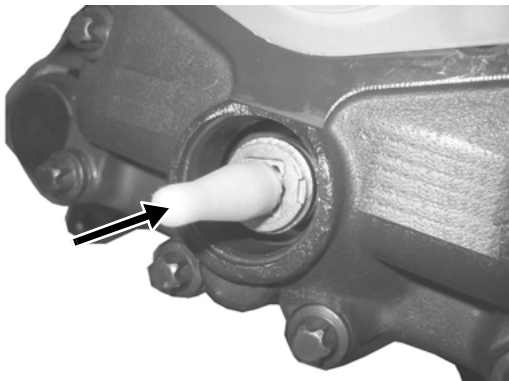
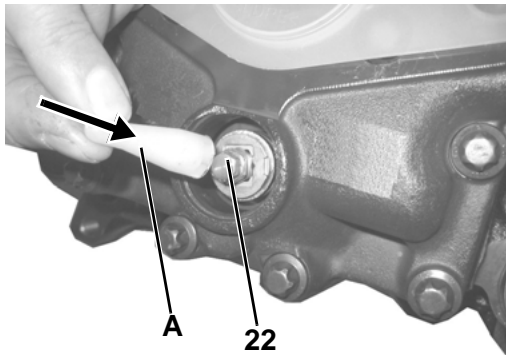

- Lightly grease the **new** protection cap (13) only at the inner sealing bead (see arrow with arrow head towards the left in the figure below).
- Place the protection cap (13) onto the mounting cap (A).
- Manually press the protection cap (13) right to the stop in the brake calliper seat.

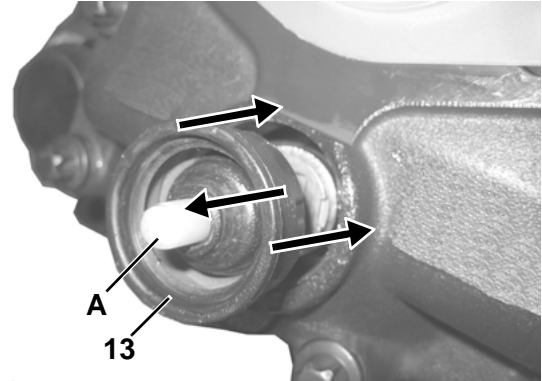

- Place the mounting bushing (B) onto the mounting cap (A).

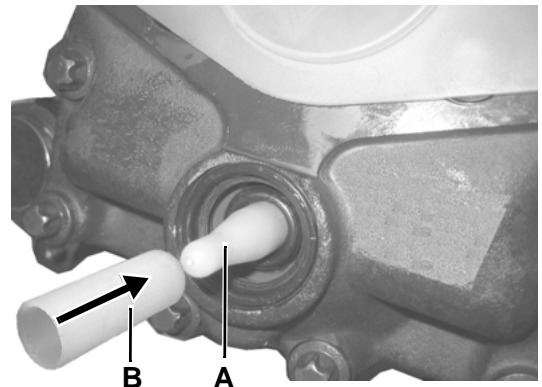

- Press the mounting bushing (B) against the inner sealing bead until the sealing bead lies in the ring groove of the adjuster.

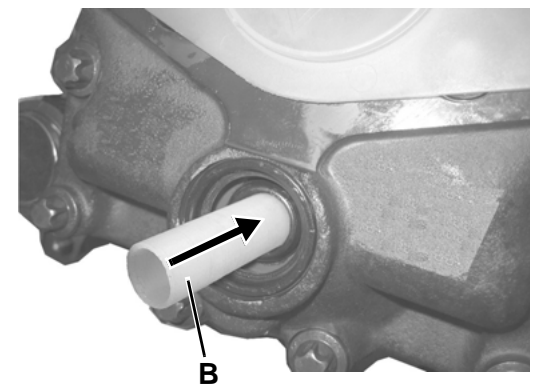

- Remove the mounting bushing (B) and mounting cap (A).

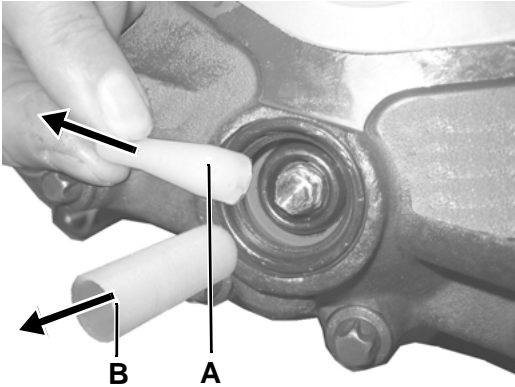

! Ensure a tight fit.



- Check of correct seat of the protection cap (13) in the brake calliper and the ring groove (see arrow in the figure below).

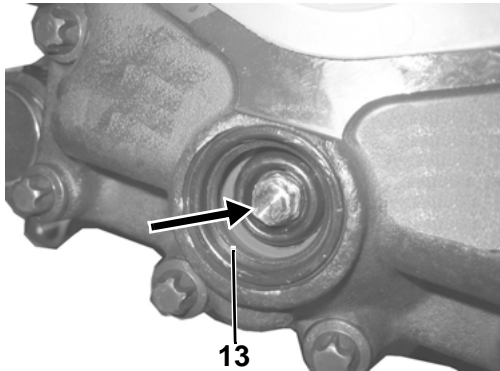

- Push the **new** sealing plug (12) into the opening of the brake calliper.

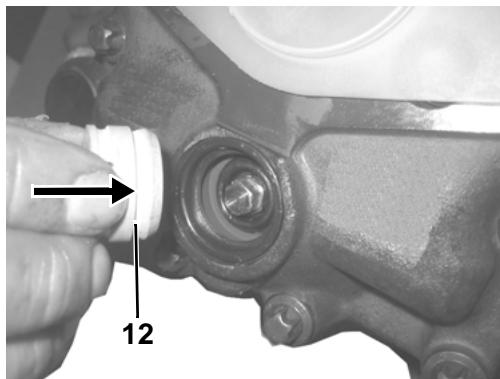

7 Replacing the brake cylinder



CAUTION! Risk of injury

- Observe all safety, repair and maintenance instructions (see chapter 1 „Important instructions and safety instructions“, page 3).
- These instructions must be observed to avoid personal injury and/or material damage.

! Only use brake cylinders as specified by the axle or vehicle manufacturers.

The instructions for breaking the brake cylinder in are for general information. Pay attention to the installation specifications and the test and installation instructions of the brake cylinder manufacturer and strictly adhere to them.

The illustrations are for example only and may deviate from the actual design.

7.1 Removing the brake cylinder

- Unscrew the air connection from the brake cylinder.

! Ensure that the air connections of the brake cylinder are not pressurised.

- Loosen the nuts of the brake cylinder (see chapter 8.2 „Widths across flats and tightening torques“, page 37, table. item V).
- Remove the brake cylinder from the brake calliper.

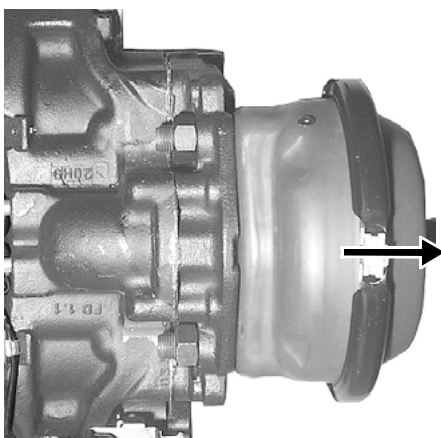

! Ensure that no dirt or moisture enters the brake when removing the brake cylinder.

7.2 Installing the brake cylinder

- Clean the sealing surface and flange area of the brake calliper.

! Ensure that no dirt or moisture enters the brake when cleaning.

- Grease the calotte in the brake lever.

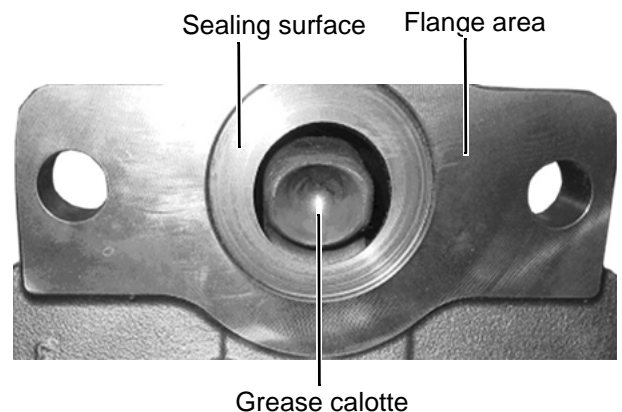

- Place the brake cylinder onto the calliper.
- Screw the brake cylinder with the **new** fastening nuts manually until the entire surface of the brake cylinder makes contact with the brake calliper.
- Tighten the brake cylinder with around 120 Nm.
- Tighten the retaining nuts to approx. 210 – 30 Nm (see chapter 8.2 „Widths across flats and tightening torques“, page 37, table, item V).

! Always use **new** retaining nuts when fitting the brake cylinder.

Depending on the installation position of the brake, ensure that the lower drainage aperture of the brake cylinder facing the ground is open.

Depending on the actuator type, the other drainage openings can either remain open or they must be sealed with a plug.

Observe the respective instructions of the brake cylinder manufacturer.

- Ensure that the brake hose is not twisted and routed so that it does not rub against the other parts.
- Ensure that the brake hose does not exert initial stress on the sliding function of the brake calliper.

- Ensure that the brake calliper movement is not obstructed over the entire displacement path.

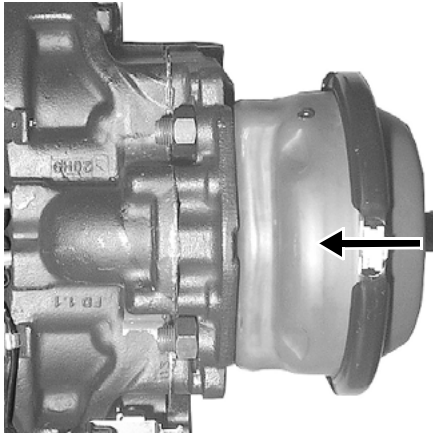

- Check the air connection for tightness.
- Perform a function and effectiveness test of the brake.

7.3 Removing the spring brake cylinders

- Secure the vehicle against rolling.
- Release the hand brake.
- Turn the mechanical release device outwards.
- Apply the hand brake.

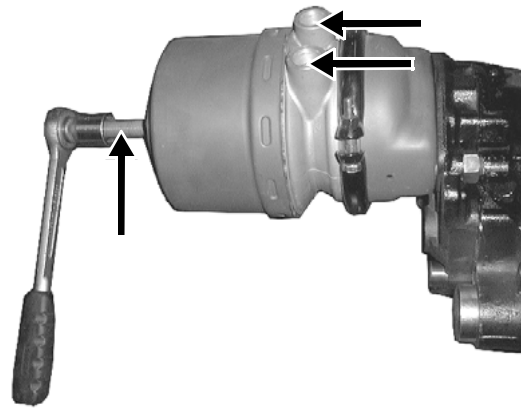

! Brake hose port 12 = unpressurised.

- Mark both brake hoses to ensure correct installation.
- Disconnect the brake hoses from the couplings.



CAUTION! **Damage to the brake hoses**

- Never remove the brake cylinders with connected brake hoses, otherwise the brake hoses could be damaged.
- Remove the brake cylinder from the brake calliper. Unscrew the hexagon head screws for this purpose and remove the brake cylinder (see chapter 8.2 „Widths across flats and tightening torques“, page 37, table 1, Position V).

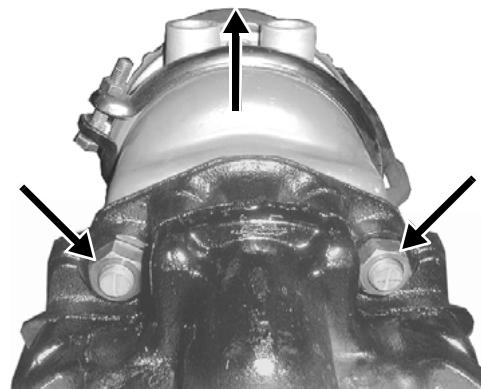

7.4 Installing the spring brake cylinder

! Depending on the installation position of the brake, only the lower drainage aperture of the brake cylinder facing the road level must be open.

Depending on the actuator type, the other drainage openings can either remain open or they must be sealed with a plug. Observe the respective instructions of the brake cylinder manufacturer.

- Clean the sealing surface and flange area of the brake calliper.
- Grease the calotte in the brake lever.

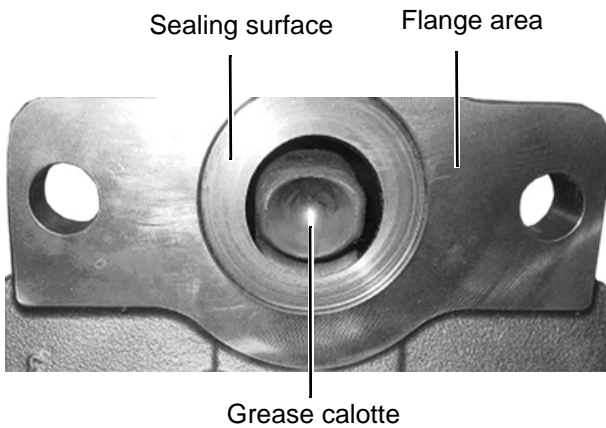

- Place the brake cylinder onto the calliper.
- Use the spanner to tighten the nuts in a diametrically opposite sequence (Table 1, Position V).

- Screw both brake hoses to the brake cylinder.

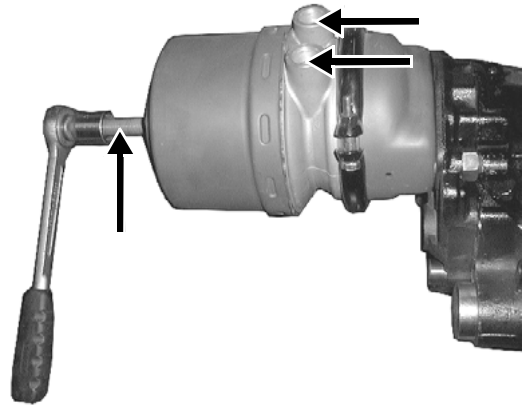

! Observe the regulations of the cylinder manufacturer.

Note correct connections.
Port 11 = Foot brake
Port 12 = Hand brake

- Release the hand brake.
- Unscrew the mechanical release device.

! The brake hoses must not be twisted and must be routed so that there is no friction with other parts over the entire suspension path.

Ensure that the brake hose does not exert initial stress on the sliding function of the brake calliper and does not obstruct brake calliper movement over the entire displacement path.

- Check the air connection for tightness.





! Perform a function and effectiveness test following the regulations of the cylinder manufacturer.

8 Appendix

8.1 WABCO tools







WABCO Basic Tools (tool kit 640 195 522 2)

Required for all WABCO compressed-air disc brakes

Item	Name	Notation
10	Handle	
11	Adapter	
12	Ring spanner / Ratchet spanner	
13	Renewal	

WABCO tools for PAN[®]17 (tool kit 640 175 521 2)

The WABCO Basic Tools (tool kit 640 195 522 2) are also required.

Item	Name	Notation
14	Drive-out bushing	
15	Drive-in bushing long 1	
16	Drive-in bushing long 2	
17	Drive-in bushing short	
18	Drive-in bushing cover	
19*)	Tool adjustment device	
20*)	Tool adjustment device	

*) These tools are part of the tool kit but are not required for the brake type PAN[®]17.

8.2 Widths across flats and tightening torques

(Also see drawing on the next page)

! Do not use motor-driven screw or torque tools!

Item	Name	Width across flats (AF) Hexagon screw		Remarks
		external	inside	
I	Hexagon Adjuster	8	–	Direction of rotation on the hexagon: <ul style="list-style-type: none"> Adjust, anti-clockwise (left) maximum 3 Nm, clearance decreases. Restore, clockwise (right), maximum 12 Nm, clearance increases.
II	Screw for Lining retainer	17	–	Tightening torque: 20 + -2 Nm
III	Couplings Brake fastener	X	–	Please note vehicle manufacturer's special assembly instructions and spanner widths.
IV	Couplings Guide pin	–	14	Tightening torque: 340 + -20 Nm Tightening sequence for guide pins: <ol style="list-style-type: none"> Fit pin (long hexagon socket screw) Play bolt (short hexagon socket screw)
V	Couplings Brake cylinder	24	–	Tightening torque: 210 -30 Nm (only applies to original WABCO cylinders) Fastening the brake cylinder to the disc brake is recommended as follows: <ul style="list-style-type: none"> Screw on the fastening nuts manually till the brake cylinder rests against the surface. Tighten the fastening nuts with approx. 120 Nm. Tighten the fastening nuts with 210 -30 Nm using a torque wrench. Only use fastening nuts once.

¹⁾ The tightening torques apply for original WABCO cylinders

8.3 Exploded view of the replacement parts

Information and publications on WABCO repair kits and service documents can be found in the product catalogue INFORM on the Internet at www.wabco-auto.com

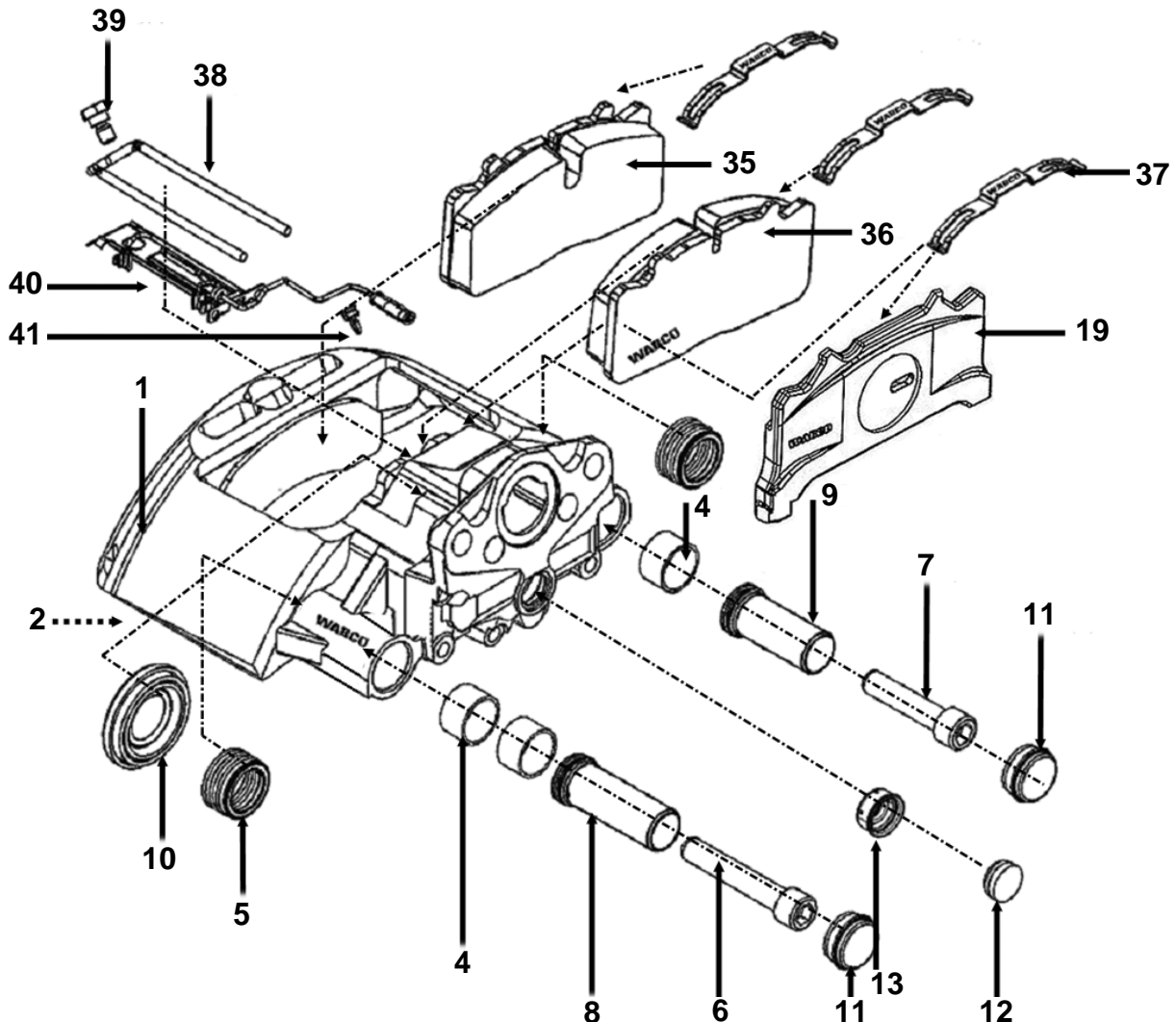

Fig. Illustration of replacement parts for a left brake

1	Brake calliper (pre-assembled)	12	Sealing plugs
2	Actuating unit	13	Protection cap for adjuster
4	Bushings for guide pins	19	Pressure plate
5	Protection caps for guide pins	35	Brake lining rim side
6	Hexagon socket screw (long)	36	Brake lining actuating side
7	Hexagon socket screw (short)	37	Hold-down springs
8	Guide pin (long)	38	Lining retainer
9	Guide pin (short)	39	Hexagon screw
10	Protection cap for adjuster screw	40	Wear indicator (pre-assembled)
11	Closing cover	41	Cable clips

8.4 Procurement and disposal of spare parts

8.4.1 Procurement of spare parts

- Identify the brake by means of the WABCO part number.



Fig. WABCO type plate

- A Vehicle manufacturer's part number
- B Production date
- C Assembly number
- D WABCO part number

- Open the product catalogue INFORM on the Internet at <http://www.wabco-auto.com>
- Enter the WABCO part number of the brake calliper.
- Click on "Repair".
- Open the spare part sheet.

8.4.2 Disposing of the brake components

- Dispose of used and replaced parts with due regard to the environment and in accordance with national and regional regulations.

Generally brake components can be scrapped.

WABCO Spare Parts List Disc Brakes 40 195 001 - Microsoft Internet Explorer

Order: Description: Position: Edition: 1

Address: <http://www.wabco-auto.com/Inform/Inform.asp?language=40195000&language=1>

Index: Product number: Publications: Symbols: Catalogue Technical Sheets: Cross Reference

WABCO: Product Catalog: Spare Parts List

Disc Brakes 40 195 001 Back

Edition: 01 06 Drawing: (if) Download Viewer

Repair kit 12 999 737 Brake pads, for two brakes
 Repair kit 12 999 738 Seals and guide bolt
 Repair Unit 12 999 756 Wear indicator, for two brakes

When changing brake pads, indicators must be ordered separately
 When changing the bolts requires tool case 12 851 021

Description	Order Number	Position	Quantity	Quantity in Repairkit
Brake Lining Support	-	1*	2	4 12 999 737
Leaf spring	-	2*	3	6 12 999 737
Hexagon Bolt	-	3*	1	2 12 999 737
Strap	-	4*	1	2 12 999 737
PlugLocking Screw	-	5*	1	1 12 999 738
PlugLocking Screw	-	5*	1	1 12 999 737
Wear Indicator	-	6-	2	2 12 999 756
pipe support	-	7-	2	5 12 999 756
Cover	-	8*	2	2 12 999 738
Screw	-	9*	1	1 12 999 738
Screw	-	10*	1	1 12 999 738
Pin	-	11*	1	1 12 999 738
Pin	-	12*	1	1 12 999 738
Bush	-	13*	3	3 12 999 738
Protection plug	-	14*	2	2 12 999 738
Gasket	-	15*	1	1 12 999 738
exchange brake without pads	40 195 001	16 -	1 a	

Legend:
 * All these parts should be replaced. ** See spare parts list with this part number.
 *** This part is not included in the repair kit and is to be ordered separately.
 a To be used if necessary - Part not shown.

Copyright WABCO No part of this publication may be reproduced without our prior permission.



WABCO (NYSE: WBC) is a leading global supplier of technologies and control systems for the safety and efficiency of commercial vehicles. Founded nearly 150 years ago, WABCO continues to pioneer breakthrough electronic, mechanical and mechatronic technologies for braking, stability

and transmission automation systems supplied to the world's leading commercial truck, bus and trailer manufacturers. With sales of \$2.5 billion in 2012, WABCO is headquartered in Brussels, Belgium. For more information, visit

www.wabco-auto.com