

Contents

General Information

Suspension/Axle Identification.....	2
Base-Axle (165- Part Number) Reference.....	3
Dressed-Axle (164- Part Number) Disc Brake/Drum Brake Glossary	4-5
Wheel-End Component Descriptions.....	6
Axle Beam Rating	7
Axle Track - Single; Dual; Wide-Base Wheel Configuration.....	8-9

Service Parts – Drum Brake Axle

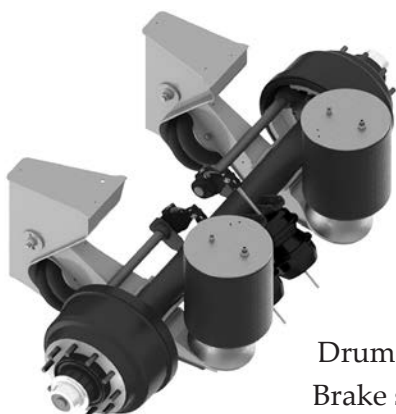

16.5" x 7.0" Brake Size

5" Standard Axle.....	10-11
5" Standard or 5 3/4" LDA with Cam Enclosure	12-13
5 3/4" LDA - Short Cam with Enclosure	14-15
Common Service Parts	16-17

12.25" x 7.5" Brake Size

5" Standard Axle.....	18-19
Drum Brake/Wheel End - Common Service Parts.....	20
Brake shoes; Dust Shields; Cam Rotation; Brake Chamber Mtg.....	21

Common Axle Components.....	22
-----------------------------	----

Wheel Bearing Adjustment	23
--------------------------------	----

Service Parts – Air Disc Brake (ADB) Axle



(D) - ADB Pattern 1 Axle (DISCONTINUED)	24-25
(W, B, L) - ADB Pattern 2 Axles.....	26-29
(P) - ADB Pattern 3 & 4 Axle (5" Axle and 5 3/4" LDA)	30-31
(S) - ADB Pattern 5 Axle.....	32-33
Bendix Caliper - Service Parts.....	34
Wabco Caliper - Service Parts	35

Maintenance

Torque Specifications.....	36
Preventive Maintenance	37
(ADB) Brake Chamber Part Number/Port Orientation.....	38
Automatic Tire Inflation System (ATIS) Information.....	39

Warranty Information	40
----------------------------	----

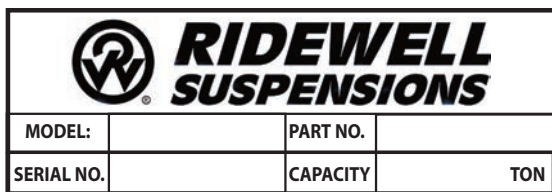

Figure 1.
The Base-Axle Part Number (165-) and the Serial Number assigned to the axle tube are listed on the Axle-Body ID Tag.

Serial Identification Tag

Suspension systems and Ridewell-branded axles can be identified by the Suspension ID and Axle-Body Identification Tags.

Axle-Body Identification Tag

The Base-Axle Part Number (165-) and the Serial Number of the axle tube are listed on the Axle-Body Identification Tag of Ridewell-branded round axles (Figure 1).

The Base-Axle Part Number applies to 5-inch “Standard” or 5 3/4-inch “Large Diameter Axle (LDA)” round axles manufactured in various axle-wall thicknesses and widths.

Axle spindles, disc or drum brake systems, and other wheel-end equipment components can be attached to the axle body to create a Dressed-Axle Configuration (Page 4).

Suspension Identification Tag

A (606-) Installation/Assembly Number will be listed as the Part Number when other system components are factory installed with the suspension (Figure 1).

The Suspension Number and Serial Number on the Suspension ID Tag refer to the model and the date of manufacture of an individual suspension system.

Please refer to the suspension number/part number and serial number on the Suspension Identification Tag when contacting Ridewell for customer service, replacement parts and warranty information.

Notes and Cautions

All work should be completed by a properly trained technician using the proper/special tools and safe work procedures.

This guidebook uses two types of service notes to provide safety guidelines, prevent equipment damage and make sure that the axles/components operate correctly. The service notes are defined as:

“NOTE”: Provides additional instructions or procedures to complete tasks and make sure that the axle/components function properly.

CAUTION Indicates a hazardous situation or unsafe practice that, if not avoided, could result in equipment damage and serious injury.

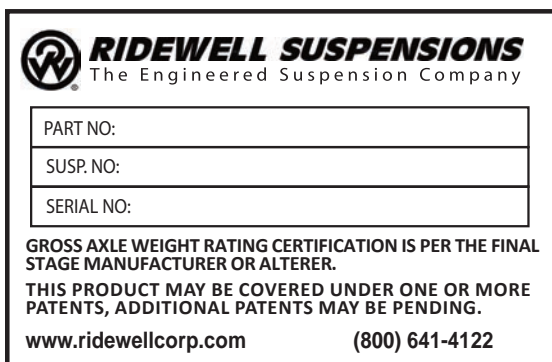

Figure 2.
The Suspension Model (Suspension Number) and the date of manufacture (Serial Number) are listed on the Suspension Identification Tag.

Base Axle Part Number

Ridewell-branded axles have a serial identification tag attached to the axle tube (body) listing the Base Axle Part Number (165xxxx). The part numbers of the brake and wheel end equipment components connected to the base axle can be found by locating the Base Axle Part Number in the chart, then searching for the component on the page number(s) referenced.

Contact Ridewell Customer Service if you have a base axle part number that is not listed in the chart.

Part Number	Page	Part Number	Page	Part Number	Page	Part Number	Page
1650035	10-11	1650107-Δ	10-11	1650188	10-11	1650307	32-33
1650036	10-11	1650108-Δ	10-11	1650192-Δ	10-11	1650312	26-29
1650053	10-11	1650109	10-11	1650193	24-25	1650325	10-11
1650054	10-11	1650110	10-11	1650196-Δ	10-11	1650341	26-29
1650056	12-13	1650111	10-11	1650201-Δ	10-11	1650347	14-15
1650057	10-11	1650112	10-11	1650205	14-15	1650348	26-29
1650059	10-11	1650114	10-11	1650206	14-15	1650351	26-29
1650061	10-11	1650119	18-19	1650207	14-15	1650352	12-13
1650062	10-11	1650120	10-11	1650213	24-25	1650353	12-13
1650063	10-11	1650123	10-11	1650214	10-11	1650359	26-29
1650064	10-11	1650127	10-11	1650215	12-13	1650360	26-29
1650069-Δ	10-11	1650128	10-11	1650216-Δ	10-11	1650362	26-29
1650070	10-11	1650131	10-11	1650219	12-13	1650365	12-13
1650071	12-13	1650134	12-13	1650222	24-25	1650366	12-13
1650072	10-11	1650136	12-13	1650227	18-19	1650367	12-13
1650074	10-11	1650138	18-19	1650228	24-25	1650368	12-13
1650076	18-19	1650140	10-11	1650229	24-25	1650369	12-13
1650077	18-19	1650141	12-13	1650234	24-25	1650370	12-13
1650085	10-11	1650146	10-11	1650235	24-25	1650371	12-13
1650087	10-11	1650148-Δ	10-11	1650236	24-25	1650372	12-13
1650088	10-11	1650149	10-11	1650237	24-25	1650373	12-13
1650089	18-19	1650150	10-11	1650239	10-11	1650380	26-29
1650090	10-11	1650151	10-11	1650240	26-29	1650389	26-29
1650091	10-11	1650155	18-19	1650241	26-29	1650058D	14-15
1650092	10-11	1650160	12-13	1650251	14-15	1650205D	14-15
1650093	10-11	1650166	12-13	1650254	26-29	1650206D	14-15
1650094	10-11	1650168	24-25	1650258	26-29	1650207D	14-15
1650096-Δ	10-11	1650169	12-13	1650259	26-29	1650251D	14-15
1650097-Δ	10-11	1650175	24-25	1650260	26-29	1650270D	14-15
1650098	12-13	1650176	24-25	1650264-Δ	10-11	1650271D	14-15
1650099	12-13	1650177	24-25	1650265	30-31	1650296D	14-15
1650100	10-11	1650178	10-11	1650266	30-31	1650297D	14-15
1650101	12-13	1650179	10-11	1650268	18-19	1650326D	14-15
1650102	12-13	1650180	10-11	1650289	32-33		
1650103-Δ	10-11	1650181	10-11	1650290	32-33		
1650104-Δ	10-11	1650182	12-13	1650294	30-31		
1650105-Δ	10-11	1650185-Δ	10-11	1650300	26-29		
1650106-Δ	10-11	1650187	24-25	1650306	30-31		

(Δ) Custom cam length needed - Contact Ridewell Customer Service

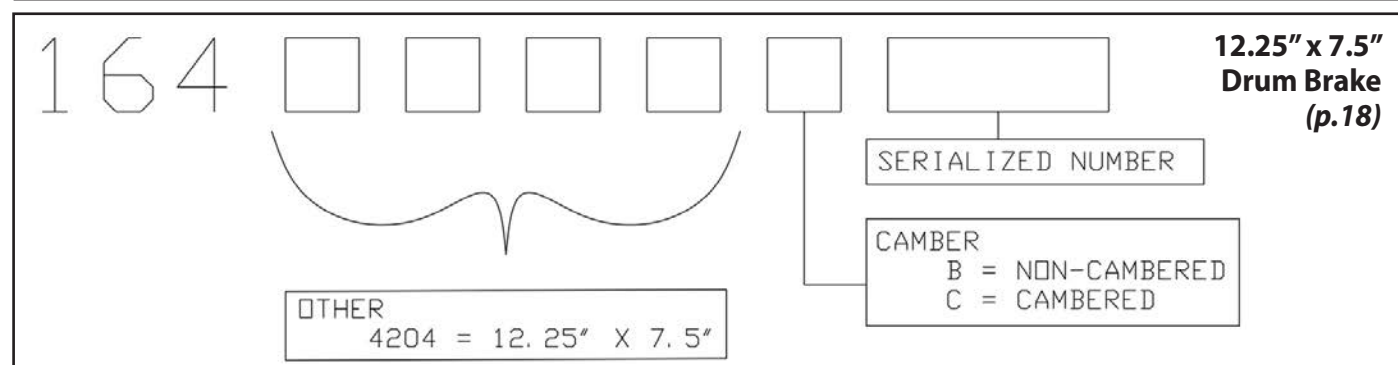
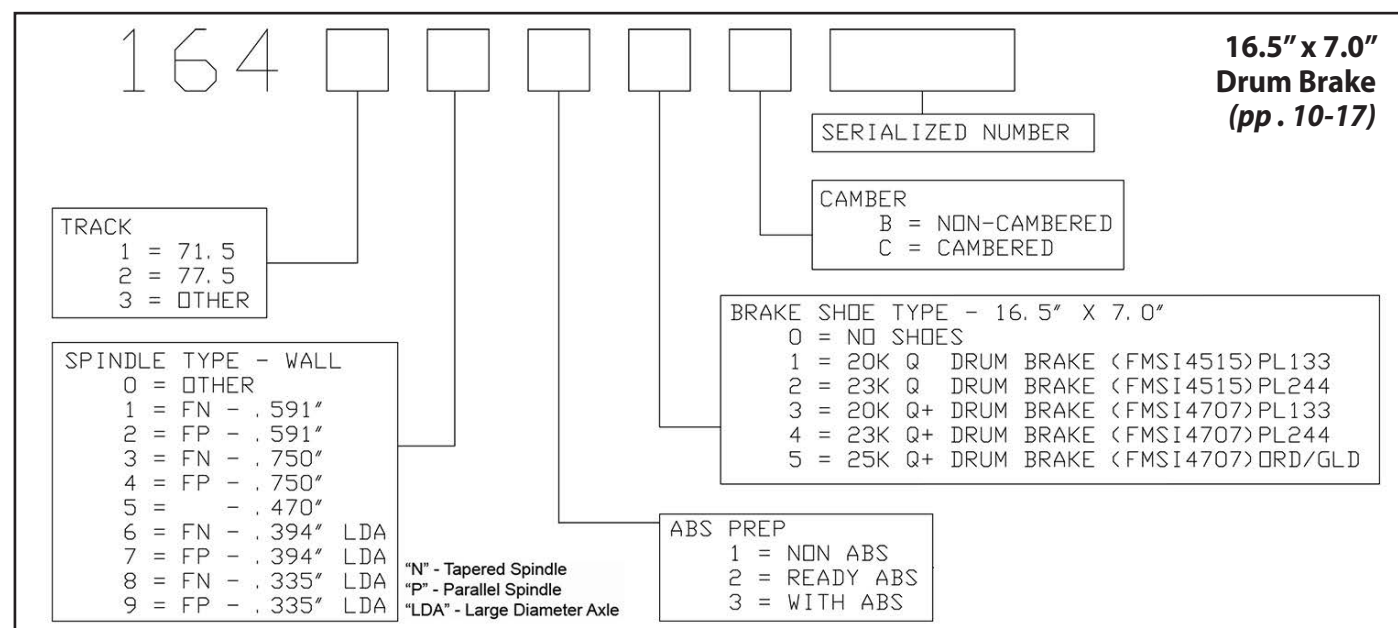
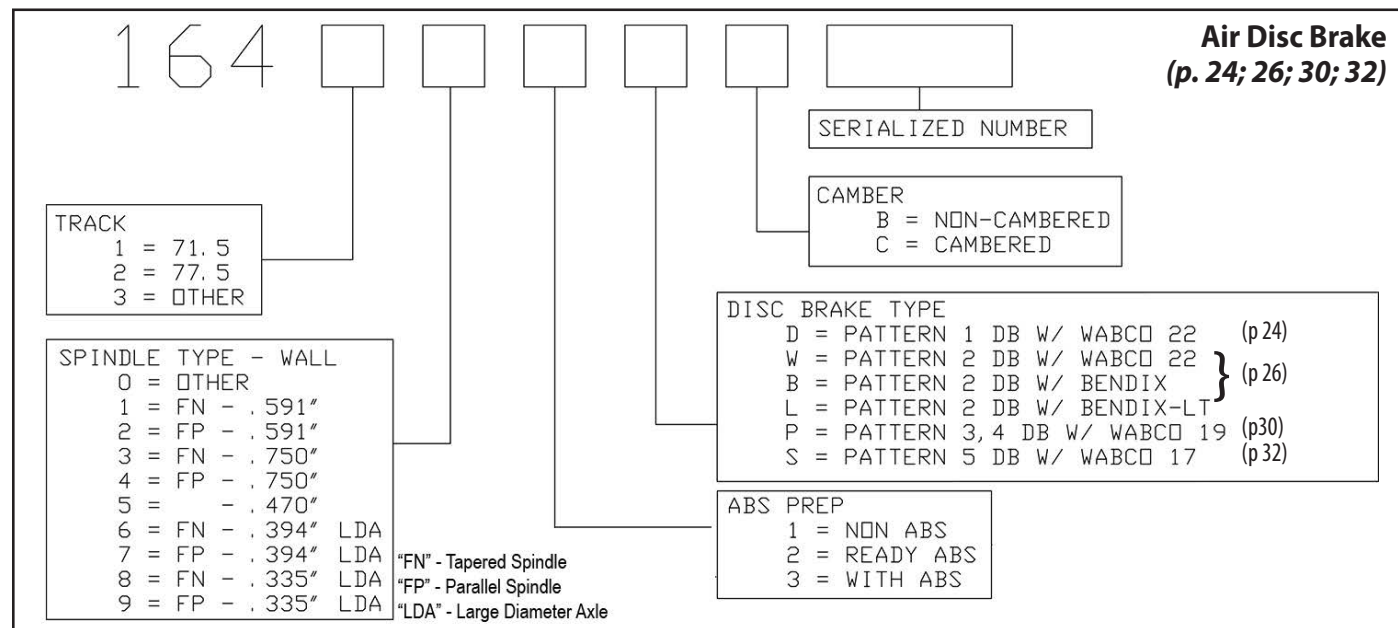
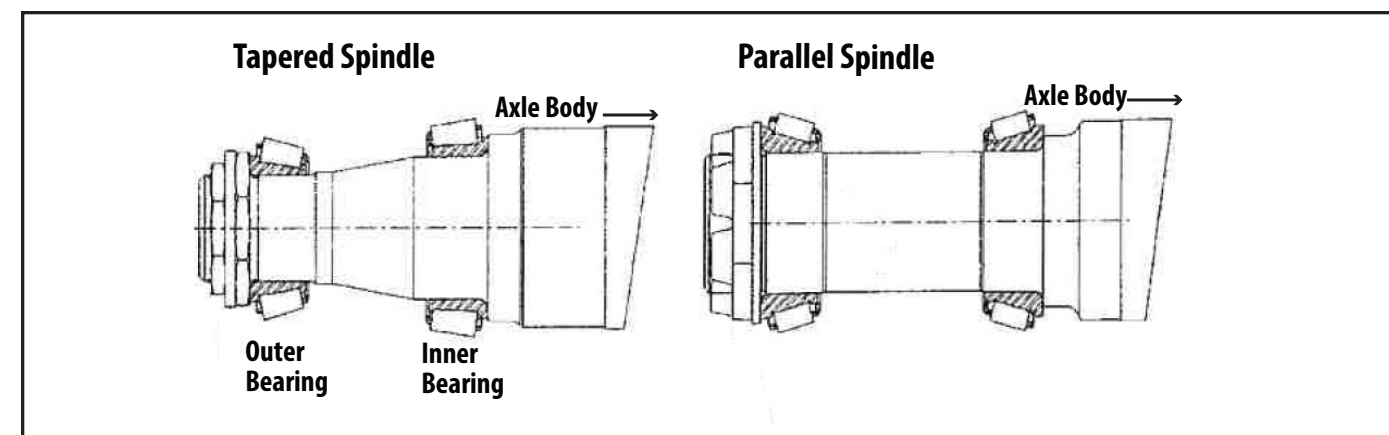

Figure 3. The 11-digit Dressed-Axle Configuration Part Number (164xxxxxxxx) provides a reference for either a standard (5-inch) or a 5 3/4-inch Large Diameter Axle (LDA) configured with a drum or disc brake.



Track (Axle Track)

The distance between the centerline of two wheels mounted on each axle end. The theoretical centerline of a dual steel-wheel configuration is used for the axle track specification.

Camber (Optional)

Axle camber is defined as the inward or outward angle of tires mounted on the axle. Positive camber means the top of the tires are farther apart than the bottom. Axles are cambered so that there is a bow in the axle. Weight is put on the axle to bring the wheel camber to zero. All cambered axles should be mounted with the center bow up.

ABS Prep

How wheel end components are prepared to accept an Anti-Lock Braking System.

1. Wheel hub is prepared without an installed tone ring.
2. Hub prep with installed tone ring
3. Both the tone ring and ABS sensor are installed.

Spindle Type - Wall

The spindle is the part of the axle end that supports the wheel end components. The spindle is either parallel to the axle body or tapered towards the axle end. Wall (thickness) affects axle load capacity - a thicker wall has a higher capacity.

Brake Rating

The maximum stopping power of the brake. Brake rating is dependent on the drum or disc brake type and size, the type of brake pad/shoe lining, the brake input power, the brake's structural rating and the tire static load radius. Brake input power for cam/disc brakes includes air chamber size and slack adjuster length.

CAUTION Brake Rating must not be over- or under-sized for the suspension application. Confirm application with Ridewell.

Standard Trailer Dimensions

Trailer suspensions are designed to fit up onto standard I-beam trailer frames at the beam centers that correspond to standard axle track widths (Figure 4).

Installation at wider beam centers will reduce suspension clearances. Installation at narrower beam centers will de-rate the axle beam capacity.

NOTE: For other, non-standard beam centers, frames, frame centers, axle track widths and wheel-end equipment, the suspension installer is responsible for verifying clearances, axle capacity, proper fit-up, and any additional required suspension support structure.

Standard Configurations	Trailer Width	Axle Track	Frame Center	Beam Center	Air Spring Center
Dual Wheel	96"	71.5"	38"	35"	31"
	102"	77.5"	44"	41"	37"
Wide-Base Wheel-Zero Offset	102"	83.5"	50"	47"	43"

Figure 4. Beam Centers - The center line-to-center line distance from one trailing arm beam to the other.

The rotating components on the end of an axle including the wheel hub, wheel bearing cups and cones, the hub seal, the hubcap and related equipment such as tire pressure control systems are considered wheel-end equipment.

Brake drums/rotors are fastened to the wheel hub. Tire/wheel assemblies are fastened to the hub with studs and nuts.

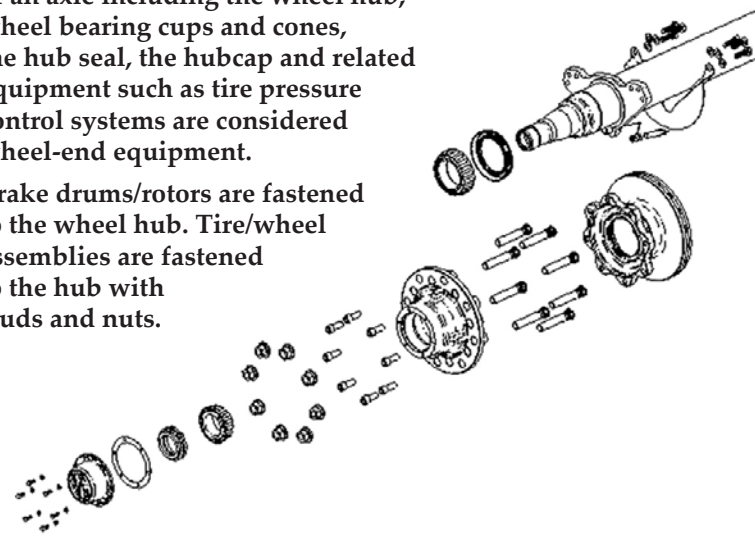

Hub Seal

A seal installed into the inboard side of the wheel hub to retain grease or oil and prevent external contamination from entering the interior hub cavity.

Hubcap Gasket/Seal

A thin, flat seal or O-ring installed between the hubcap and the outboard face of the hub that prevents lubricant from leaking out of the hub and contaminants from entering the hub.

Dust Shield

A thin sheet of metal bolted in place behind the rotor to protect from rocks, grit, and other debris found on the road. There are two types - rotor shields and brake-pad shields.

ABS (Anti-Lock Braking System)

ABS system components include a toothed wheel (tone ring) mounted on the hub of each monitored wheel; an electronic sensor that has one end against the tooth wheel to monitor and transmit wheel speed and a sensor clip that holds the sensor in place.

ABS Tone Ring (Exciter ring)

A notched ring (80-100 equally spaced slots) attached to a wheel hub or behind a brake rotor that is read by an ABS speed sensor to determine the speed of an individual wheel.

Hub-Piloted Mounting

A wheel mounting system in which a boss on the hub is used to locate the center hole of a hub-piloted wheel. Flanged nuts are used to attach the wheel to the flat face of the wheel disc.

Stud-Piloted Mounting

A wheel mounting system in which location and fastening of the wheel are both accomplished by nuts which fit corresponding studs at each wheel bolt hole.

5-inch Axle (Standard)			Tube Wall	
			0.591"	0.75"
Track Width (Inches)	Beam Centers (Inches)	Moment Arm (Inches)	Axle Beam Capacity GAWR (lbs)	Axle Beam Capacity GAWR (lbs)
71.5"	38	16.75	23,000	25,000
	37	17.25	23,000	25,000
	36	17.75	23,000	25,000
	35	18.25	23,000	25,000
	34	18.75	22,387	24,333
	33	19.25	21,805	23,701
	32	19.75	21,253	23,101
	31	20.25	20,728	22,531
	30	20.75	20,229	21,988
	29	21.25	19,753	21,471
77.5"	44	16.75	23,000	25,000
	43	17.25	23,000	25,000
	42	17.75	23,000	25,000
	41	18.25	23,000	25,000
	40	18.75	22,387	24,333
	39	19.25	21,805	23,701
	38	19.75	21,253	23,101
	37	20.25	20,728	22,531
	36	20.75	20,229	21,988
	35	21.25	19,753	21,471
5.75-inch Axle Large Diameter Axle (LDA)			Tube Wall	
			0.335" <i>(On-Hwy Use Only)</i>	0.394"
Track Width (Inches)	Beam Centers (Inches)	Moment Arm (Inches)	Axle Beam Capacity GAWR (lbs)	Axle Beam Capacity GAWR (lbs)
71.5"	38	16.75	23,000	25,000
	37	17.25	23,000	25,000
	36	17.75	23,000	25,000
	35	18.25	23,000	25,000
	34	18.75	22,387	24,333
	33	19.25	21,805	23,701
	32	19.75	21,253	23,101
	31	20.25	20,728	22,531
	30	20.75	20,229	21,988
	29	21.25	19,753	21,471
77.5"	44	16.75	23,000	25,000
	43	17.25	23,000	25,000
	42	17.75	23,000	25,000
	41	18.25	23,000	25,000
	40	18.75	22,387	24,333
	39	19.25	21,805	23,701
	38	19.75	21,253	23,101
	37	20.25	20,728	22,531
	36	20.75	20,229	21,988
	35	21.25	19,753	21,471

Gross Axle Weight Rating (GAWR) is a term used to specify the maximum load-carrying capacity of a single axle assembly. The GAWR is determined by the component - the axle body, the suspension, brakes, hubs, bearings, and wheels and tires - with the lowest rated capacity.

Vehicle manufacturers should follow the instructions supplied by other component manufacturers to determine the ratings for components not produced by Ridewell to determine the correct Gross Axle Weight Rating (GAWR).

This will ensure the vehicle manufacturer is in compliance with the appropriate Federal regulations.

Axle Track – Wheel Configuration

Standard Configuration Dual Wheel	Trailer Width	Axle Track	Frame Center	Beam Center	Air Spring Center
	96"	71.5"	38"	35"	31"
	102"	77.5"	44"	41"	37"

Dual Wheel Configuration

- (S) - Wheel Spacing
- (O) - Wheel Offset
- (W) - Tire Width
- (T) - Axle Track
- (TT) - Tire Track
- (TOD) - Tire Overall Diameter
- (ITW) - Inside Tire Width
- (OTW) - Outside Tire Width
- (SLR) - Static Load Radius

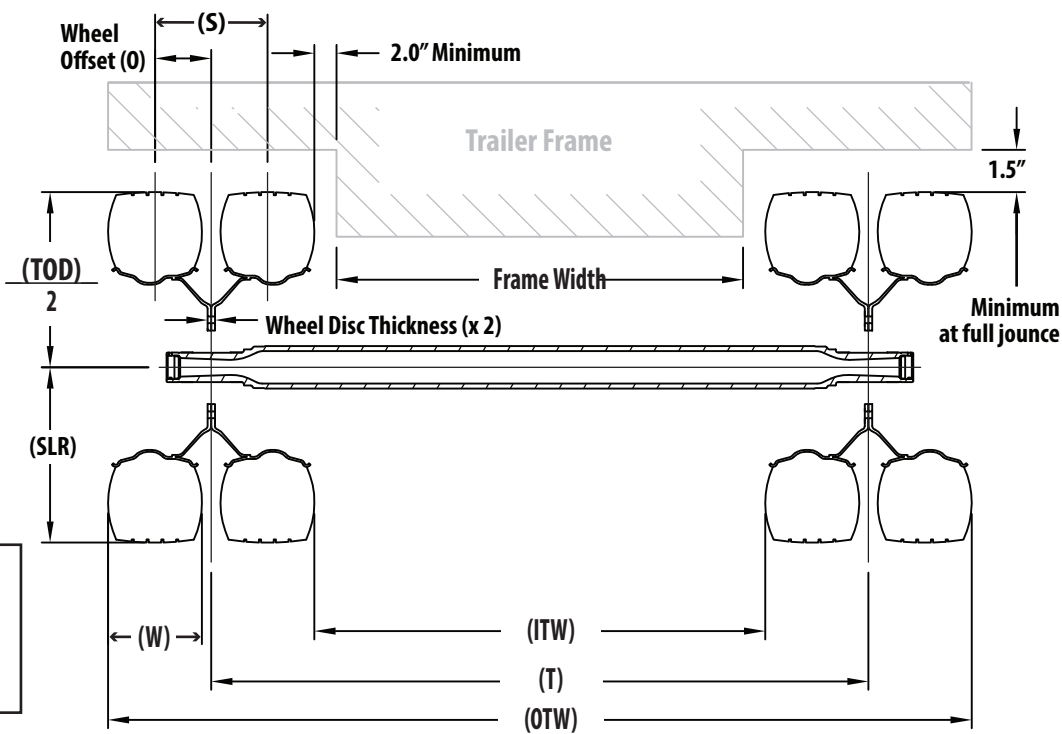

Dual Wheel Calculations

$$(S) = 2 \times O$$

$$(OTW) = T + S + W$$

$$(ITW) = T - S - W$$

Single Wheel (Outset)

Axle and Bearing Rating:

Tapered (FN) spindles are not approved for use with 2-inch outset wheels. Parallel (FP) spindles are recommended for outset applications.

Offset wheels used in a single-tire configuration can reduce the axle beam rating and bearing life.

Using inset wheels in a single-tire configuration will not affect axle beam rating, but can reduce the bearing life.

Using outset wheels in a single-tire configuration moves the load point away from the center of the axle, increases the bending load in the axle, and reduces the axle beam rating and bearing life.

Contact the Ridewell Engineering Dept. to determine the rating for an axle that uses inset or outset wheels in a single-tire configuration.

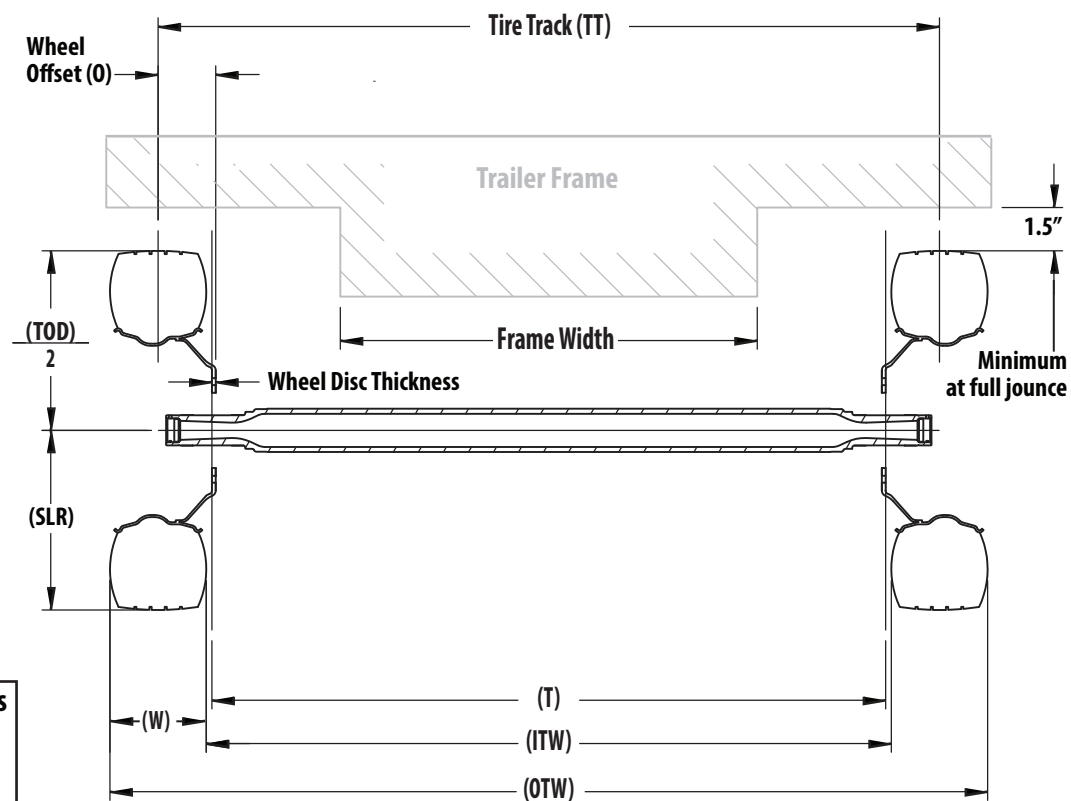

Single Wheel Calculations

$$(TT) = T + (2 \times O) - 7/8$$

$$(OTW) = TT + W$$

$$(ITW) = TT - W$$

Axle Track – Wheel Configuration

Wide-Base Wheel Configuration

- (T) - Axle Track
- (TT) - Tire Track
- (S) - Wheel Spacing
- (O) - Wheel Offset
- (W) - Tire Width
- (TOD) - Tire Overall Diameter
- (ITW) - Inside Tire Width
- (OTW) - Outside Tire Width
- (WOS) - Wheel Outset
- (WIS) - Wheel Inset
- (SLR) - Static Load Radius

Std Config. Wide-Base Wheel-Zero Offset	Trailer Width	Axle Track	Frame Ctr	Beam Ctr	A/SpG Ctr
	102"	83.5"	50"	47"	43"

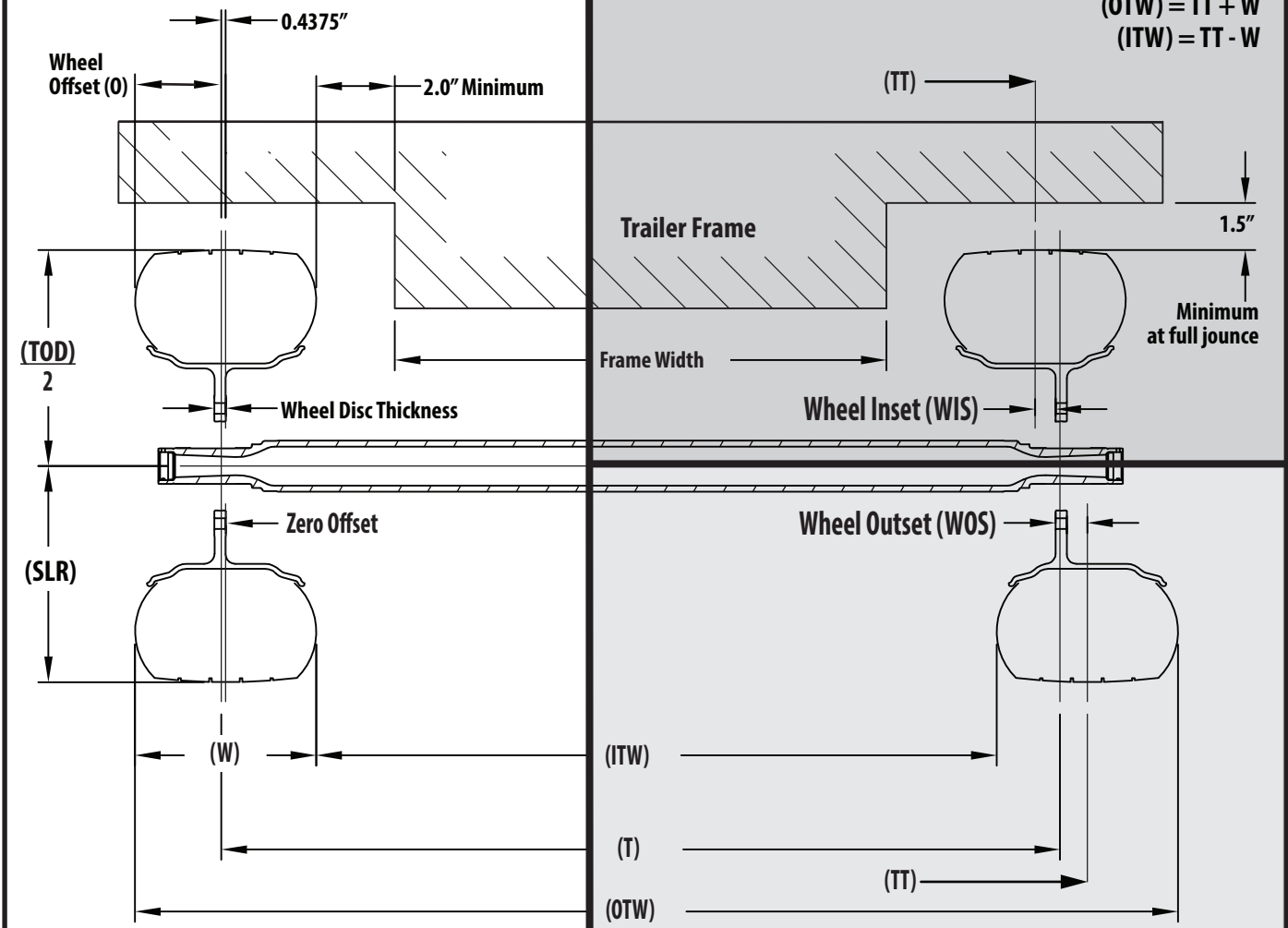

Zero Offset Wheel Calculations

$$(O) = W/2$$

$$(TT) = T - 7/8$$

$$(OTW) = TT + W$$

$$(ITW) = TT - W$$

Outset Wheel Calculations

$$(TT) = T + (2 \times WOS) - 7/8$$

$$(OTW) = TT + W$$

$$(ITW) = TT - W$$

Axle and Bearing Rating:

Tapered (FN) spindles are not approved for use with 2-inch outset wide-base wheels. Parallel (FP) spindles are recommended for outset applications.

Offset wheels used in a single-tire configuration can reduce the axle beam rating and bearing life.

Using inset wheels in a single-tire configuration will not affect axle beam rating, but can reduce the bearing life.

Using outset wheels in a single-tire configuration moves the load point away from the center of the axle, increases the bending load in the axle, and reduces the axle beam rating and bearing life.

Contact the Ridewell Engineering Dept. to determine the rating for an axle that uses inset or outset wheels in a single-tire configuration.

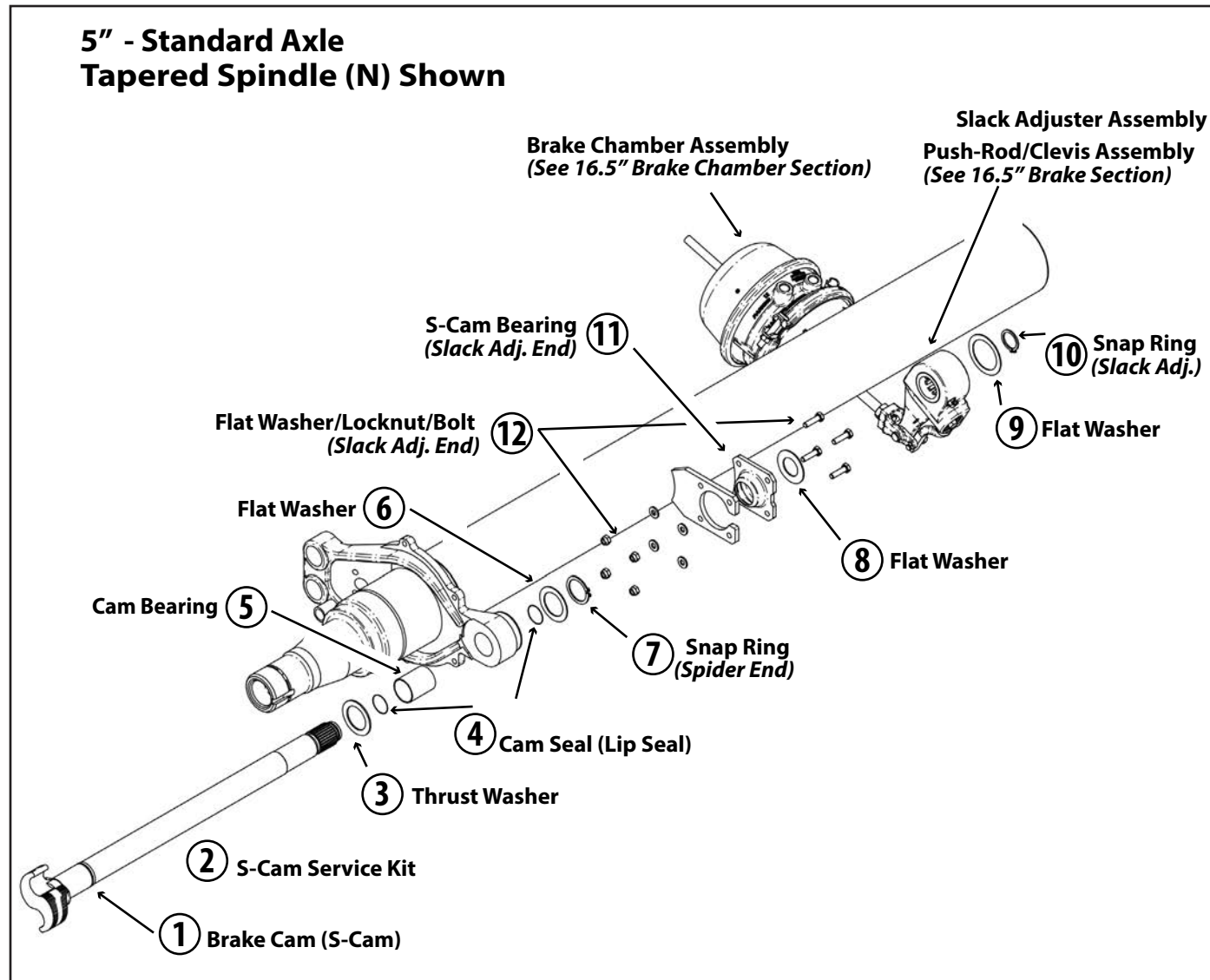

DWG No.	QTY (Per Axle)	5"-Standard Axle	Item Description	
1	1	1667591B104	S-Cam, left-hand (613 mm)	
	1	1667591B204	S-Cam, right-hand (613 mm)	
	See page three for part number of base axle that requires custom cam length			
	1	165xxxx-Δ	Left-hand S-Cam - Contact Ridewell for cam length	
	1	165xxxx-Δ	Right-hand S-Cam - Contact Ridewell for cam length	
2	1	1667591B054	Cam Service Kit	
3	Included in Service Kit	2	1667591B043 S-Cam thrust washer (Spider End)	
4		4	1667591B038 S-Cam Lip Seal (Spider End)	
5		2	1667591B039 S-Cam bearing (Spider End)	
6		2	1667591B014 S-Cam washer (Spider End)	
7		2	1667591B015 S-Cam snap ring (Spider End)	
8		20	1667591B044 S-Cam spacer washer (Slack Adjuster End)	
9		2	1667591B016 S-Cam washer (Slack Adjuster)	
10		2	1667591B017 S-Cam snap ring (Slack Adjuster)	
11		2	1667591B045 S-cam support bearing (Slack Adjuster End)	
12		8	1150063	Locknut - M8 (Cam-Slack Adjuster End)
		8	1140081	Bolt (HHCS) – M8 x 30mm (Cam-Slack Adjuster End)
	8	1160031	Flat Washer (Cam-Slack Adjuster End)	

5" (Standard) and 5 3/4" (Large Diameter Axle)
Tapered Spindle (N) Shown

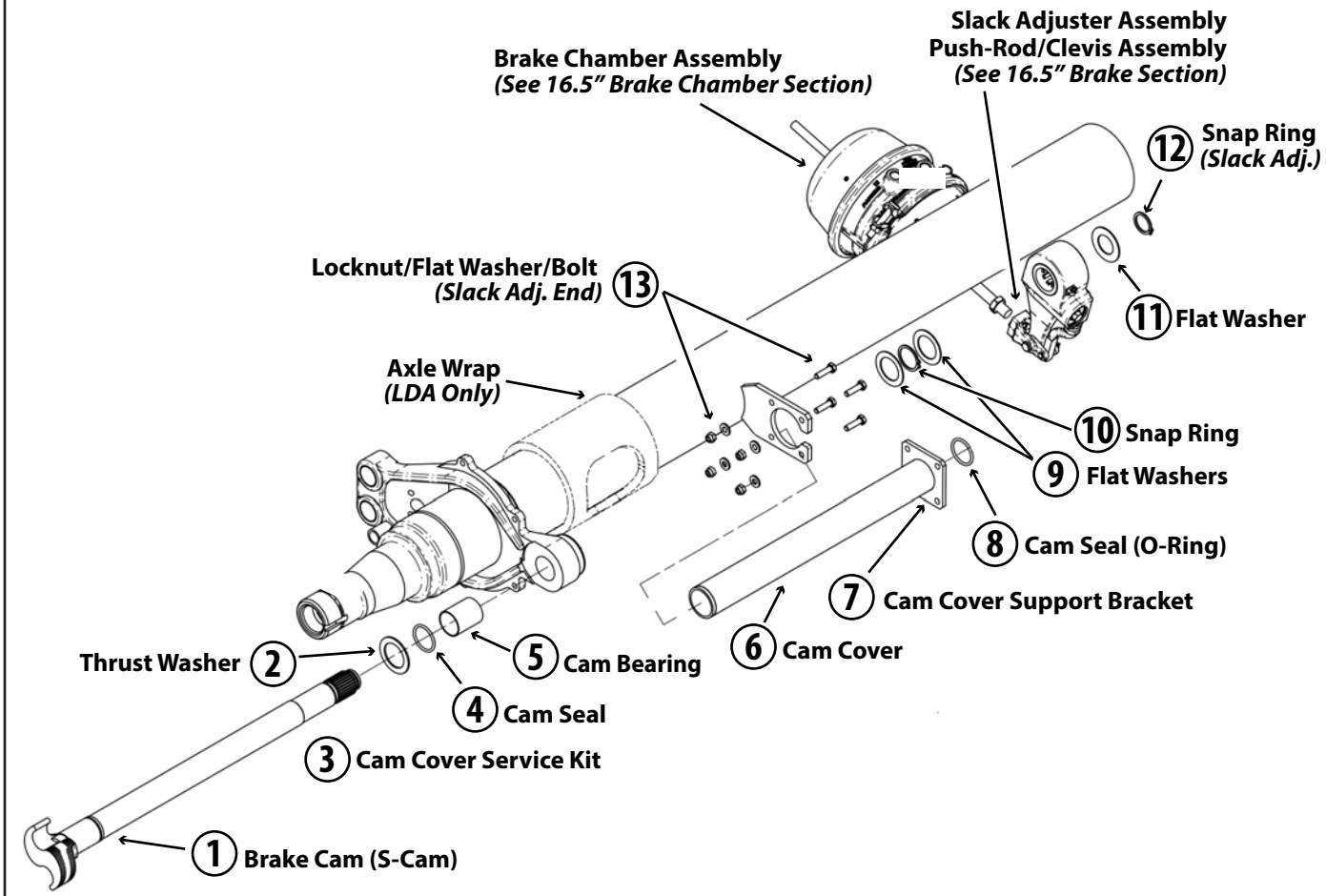

DWG No.	QTY (Per Axle)	5" – Standard Axle 5 3/4" – LDA	Item Description	
1	1	1667591B106	S-Cam, left-hand (613 mm)	
	1	1667591B206	S-Cam, right-hand (613 mm)	
2	2	1667591B043	S-Cam thrust washer (Spider End)	
3	2	1660306	Cam Cover Service Kit	
4	Included in Service Kit	1 1667591B038	S-Cam seal (Spider End)	
5		1 1667591B039	S-Cam bearing (Spider End)	
6		1 1667591B036	Cam cover assembly inc. bushings (536 mm)	
7		1 1667591B037	Support bracket plate (2" Universal) - Slack Adjuster End	
8		1 1667591B040	S-Cam O-Ring seal (slack adjuster)	
9		10 1667591B044	S-Cam spacer washer (Slack Adj. End)	
10		1 1667591B009	S-Cam snap ring	
11		2	1667591B016	S-Cam spacer washer (slack adjuster)
12		2	1667591B017	S-Cam snap ring (slack adjuster)
13		8	1150063	Locknut - M8 (Cam Enclosure-Slack End)
	8	1140081	Bolt (HHCS) – M8 x 30mm (Cam Enclosure-Slack End)	
	8	1160031	Flat Washer (Cam Enclosure-Slack End)	

5 3/4" Large Diameter Axle (LDA)
Short Cam/Tapered Spindle (N) Shown

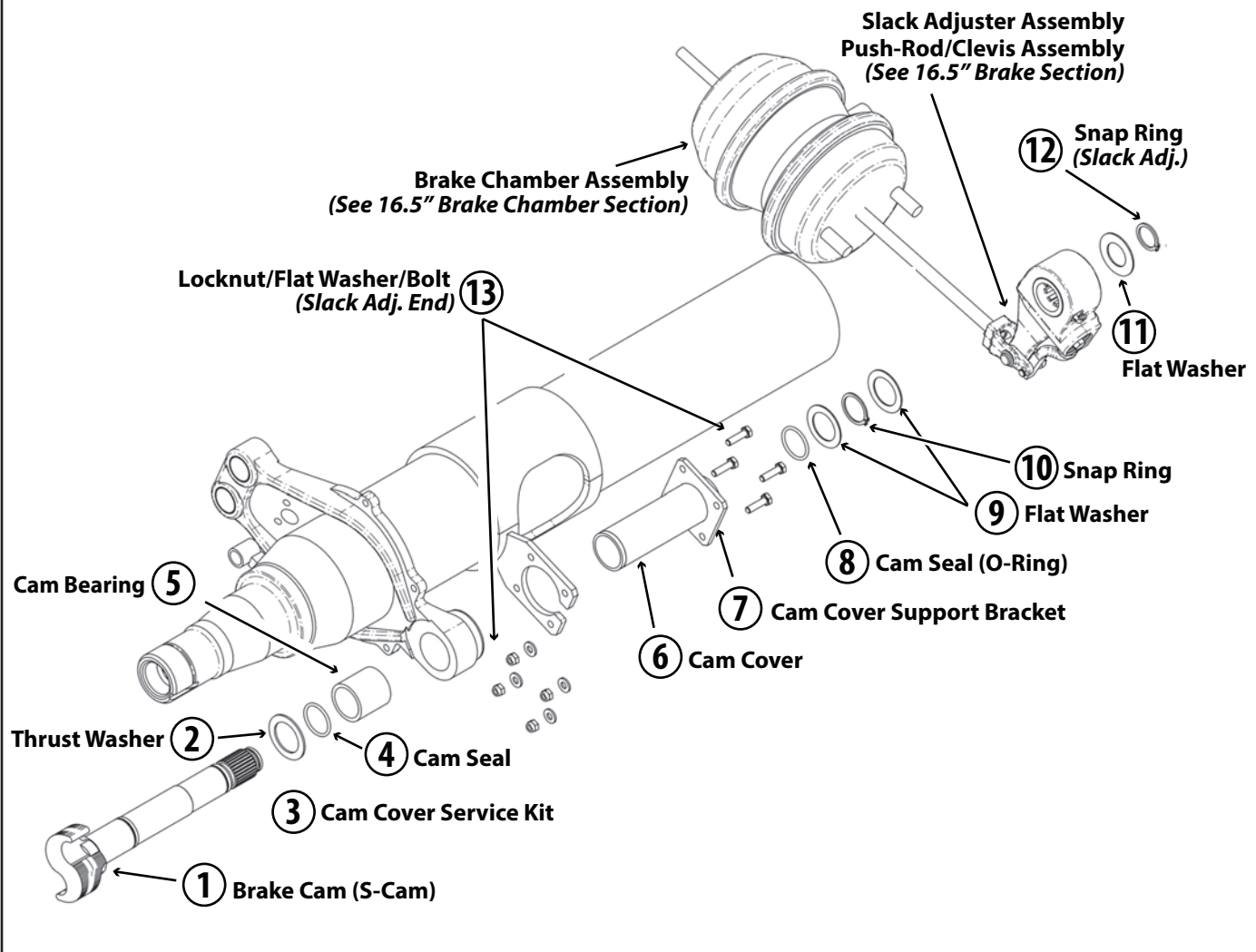

DWG No.	QTY (Per Axle)	5 3/4" - LDA	Item Description
1	1	1667591B108	LDA-S-Cam, left hand (283 mm)
	1	1667591B208	LDA-S-Cam, right hand (283 mm)
2	2	1667591B043	S-Cam thrust washer (Spider End)
3	2	1660387	LDA - S-Cam Cover Service Kit (283 mm)
4	Included in Service Kit	1 1667591B038	S-Cam Seal (Spider End)
5		1 1667591B039	S-Cam Bearing (Spider End)
6		1 1667591B049	LDA Cam Cover Assembly (169.5 mm)-Includes Bushings
7		1 1667591B037	Support bracket plate (2" Universal)-Slack Adjuster End
8		1 1667591B040	S-Cam O-Ring seal (slack adjuster)
9		10 1667591B044	S-Cam spacer washer (Slack Adj. End)
10		1 1667591B009	S-Cam snap ring
11	2	1667591B016	S-Cam spacer washer (slack adjuster)
12	2	1667591B017	S-Cam snap ring (slack adjuster)
13	8	1150063	Locknut - M8 (Cam Enclosure-Slack End)
	8	1140081	Bolt (HHCS) - M8 x 30mm (Cam Enclosure-Slack End)
	8	1160031	Flat Washer (Cam Enclosure-Slack End)

**Components -
16.5"x7.0" Brake Size**

Brake Chamber - (16.5" x 7.0" Brake Size)					
Part Number	Brake Chamber Type	Stroke Length	Push-Rod Length (in)	Manufacturer	Notes
5" Standard Axle (Straight)					
1660191	Type 20	2.50	5.750	DiPro	
1660421	Type 30	2.50	5.700	Haldex	
1660176	Type 30	2.50	5.750	DiPro	
1660259	Type 30	2.50	5.750	FUWA	
1664702B303	30/30	2.50	5.625	MGM	
1660174	30/30	2.50	5.750	DiPro	
1660285	30/30	2.50	5.750	FUWA	
1660381	30/30	2.50	5.750	TSE	OMNI
1660550	30/30	2.50	5.750	Wabco	TRISTOP IBV
1660250	30/30	2.50	5.700	Haldex	Gold Seal (GS)
1660357	30/30	3.00	5.750	TSE	OMNI
1660382	30/30	3.00	5.750	TSE	
1660345	30/30	3.00	5.625	MGM	
1660342	30/30	3.00	5.625	MGM	
5 3/4" Large Diameter Axle - Overslung (RAR-266 Suspension)					
1667591B047	30/30	2.50	9.750	FUWA	
1660598	Type 30	2.50	9.900	Haldex	
1667591B053	30/30	2.50	9.800	Haldex	Gold Seal (GS)
1667591B055	30/30	2.50	9.800	Haldex	Life Seal (LS)
1660551	30/30	2.50	9.800	Wabco	TRISTOP IBV
1660605	30/30	3.00	9.750	TSE	OMNI
5 3/4" Large Diameter Axle - Underslung (RAR-266 Suspension)					
1667591B057	30/30	2.50	5.750	FUWA	Long Cam
Long Push-Rod - Cut push-rod to required length					
1660283	30/30	2.50	12.0	DiPro	Ships uncaged

Slack Adjuster (Brake Size - 16.5" x 7.0")				
Part Number	Slack Size	Spline	Manufacturer	Clevis/Anchor Pin
1660501	5.5"	28	Gunite	Requires Clevis-1660290
1664206B038	5.5"	28	Haldex	Requires Clevis-1667591B001; Anchor Pin-1667511B006
1660179	5.5"	28	Bendix	Includes Clevis
1660173	6"	28	Bendix	Includes Clevis
1660289	6"	28	Gunite	Requires Clevis-1660290
1664206B011	6"	28	Haldex	Requires Clevis-1667591B001; Anchor Pin-1667511B006
1667591B048	6"	28	FUWA	Includes Clevis

**Components -
16.5"x7.0" Brake Size**

Hub and Drum (Hub-Piloted) - 10-Stud x 11.25" Bolt Circle										
Spindle	Hub Mtrl	Drum Mtrl	Stud Length	Tone Ring	Side Fill Port	Hub Part Number	Drum Part Number	Hub MFG	Hub & Drum Part Number	Wheel Stud Part Number
P	Cast Iron-Easy Roll	C'Fuz*	Long	Yes	No	1660389	1667511B027	WEMC		02-00045
	Cast Iron	C'Fuz	Long	No	Yes	1660234	1667511B027	Gunite		W1402
	Cast Iron	C'Fuz	Long	Yes	Yes	1660235	1667511B027	Gunite		W1402
	Cast Iron	C'Fuz	Long	Yes	Yes	1660344	1667511B027	KIC		1660083
	Cast Iron	Cast Iron	Long	No	Yes			KIC	1660060	1660083
	Cast Iron	Cast Iron	Short	Yes	Yes			KIC	1660069	PRT-00117
	Cast Iron	Cast Iron	Short	No	Yes			KIC	1660157	PRT-00117
	Cast Iron	Cast Iron	Long	Yes	Yes			KIC	1660186	1660083
	ALUM	C'Fuz	Long	Yes	Yes	1660196	1667511B027	ConMet		102292
	ALUM	Cast Iron	Long	Yes	Yes	1660196	1667591B031	ConMet		102292
	ALUM	Cast Iron	Long	Yes	Yes	1660196	1667591B034	ConMet		102292
	ALUM	C'Fuz	Long	No	Yes	1660266	1667511B027	ConMet		102291
	ALUM	C'Fuz	Long	Yes	Yes	1660277	1667511B027	ConMet		102291
	ALUM	Cast Iron	Long	Yes	Yes	1660277	1667591B031	ConMet		102291
	ADI	C'Fuz	Short	No	No	1660187	1667511B027	WEMC		02-00110
	ADI	C'Fuz	Long	Yes	Yes	1660213	1667511B027	WEMC		1660610
	ADI	Cast Iron	Long	Yes	Yes	1660213	1667591B031	WEMC		1660610
	ADI	C'Fuz	Long	No	Yes	1660251	1667511B027	WEMC		1660610
	ADI	C'Fuz	Short	Yes	No	1660340	1667511B027	WEMC		02-00110
	N	Cast Iron-Fat Boy		Long	Yes	No	1667511B034		WEMC	
Cast Iron		C'Fuz	Long	Yes	Yes	1667511B035	1667511B027	KIC		1660083
Cast Iron		Cast Iron	Long	No	Yes			KIC	1667511B000	1660083
Cast Iron		Cast Iron	Short	No	Yes			KIC	1667511B004	PRT-00117
Cast Iron		Cast Iron	Short	Yes	Yes			KIC	1667511B015	PRT-00117
Cast Iron		Cast Iron	Long	Yes	Yes			KIC	1667511B016	1660083
ALUM		C'Fuz	Long	Yes	Yes	1660249	1667511B027	ConMet		102190
ALUM		X30	Long	Yes	Yes	1667511B019	1667511B013	ConMet		102189
ALUM		C'Fuz	Long	Yes	Yes	1667511B019	1667511B027	ConMet		102189
ADI		Cast Iron	Long	Yes	Yes	1667511B026		WEMC		1660610
ADI	C'Fuz	Long	Yes	Yes	1667511B026	1667511B027	WEMC		1660610	
1660057						Flanged Wheel Nut-M22x1.5x33 (1.30" x 1.22") - See Drum Brake/Wheel End Parts				

*Centrifuse®

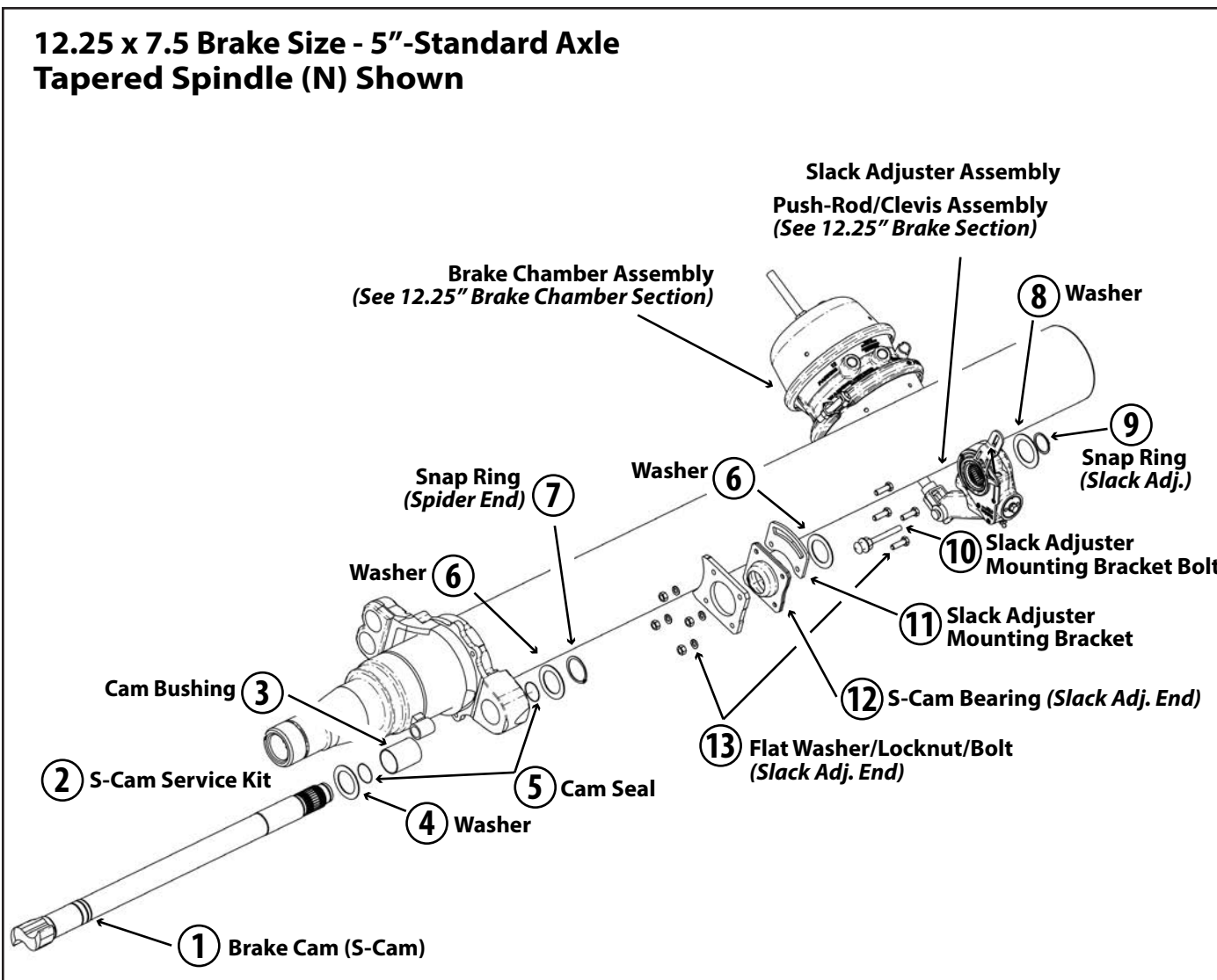

DWG No.	QTY (Per Axle)	Part Number/ MFG Part Number	Item Description (5" Axle - 12.25x7.5 Brake Size)	
1	1	Meritor - R607253	S-Cam, left-hand (594 mm)	
	1	Meritor - R607254	S-Cam, right-hand (594 mm)	
2	1	Meritor - R615020	Cam service kit	
3	Included in Service Kit	2 Meritor - R657001	S-Cam Bushing (Spider End)	
4		2 Meritor - E-719	S-Cam washer (Spider End)	
5		4 Meritor - R627018	S-Cam seal (Spider End)	
6		8 1667591B016	S-Cam washer (Slack Adjuster End)	
7		4 Meritor - 1229-Z-1118	S-Cam snap ring (Spider End)	
8		2 1667591B044	S-Cam spacer washer (Slack Adjuster End)	
9		2 1667591B017	S-Cam snap ring (Slack Adjuster End)	
10		2	1667511B006	Slack Adjuster Mounting Bracket Bolt (Flat)
11		2	1667591B056	Slack Adjuster Mounting Bracket
12	2	1667591B045	S-Cam support bearing (Slack Adjuster End)	
13	8	1150063	Locknut - M8 (Cam-Slack Adjuster End)	
	8	1140081	Bolt (HHCS) – M8 x 30mm (Cam-Slack Adjuster End)	
	8	1160031	Flat Washer (Cam-Slack Adjuster End)	

Brake Chamber (Brake Size-12.25" x 7.5")					
Part Number	Brake Chamber Type	Stroke Length	Push-Rod Length	Manufacturer	Notes
1664204B004	Type 30	2.50	4.25	DiPro	
1664204B003	30/30	2.50	4.25	DiPro	

Slack Adjuster (Brake Size-12.25" x 7.5")				
Part Number	Slack Size	Spline	Manufacturer	Clevis Included/Added Kit
1664204B005	6"	28	FUWA	Requires Clevis-1667591B001 (Includes Anchor Pin)

Hub and Drum (Hub-Piloted) – Brake Size-12.25" x 7.5" (8-Stud x 10.83" Bolt Circle)										
Spindle	Hub Material	Drum Mtrl	Stud Length	Tone Ring	Side Fill Port	Hub Part Number	Drum Part Number	Manuf.	Hub & Drum Part Number	Wheel Stud Part Number
N	Cast Iron	Cast Iron	Short	Yes	Yes	Hub-0013FT	54244-01	KIC	1664204B001	PRT-00117
	Cast Iron	Cast Iron	Short	No	Yes	Hub-0013F	54244-01	KIC	1664204B002	PRT-00117
	Cast Iron	Cast Iron	Long	No	Yes	Hub-0013FL	54244-01	KIC	1664205B004	PRT-00118
	Cast Iron	Cast Iron	Long	Yes	Yes	1664205B013	54244-01	KIC	1664205B005	PRT-00118
1660057	Flanged Wheel Nut-M22x1.5x33 (1.30" x 1.22") - See Drum Brake/Wheel End Parts									

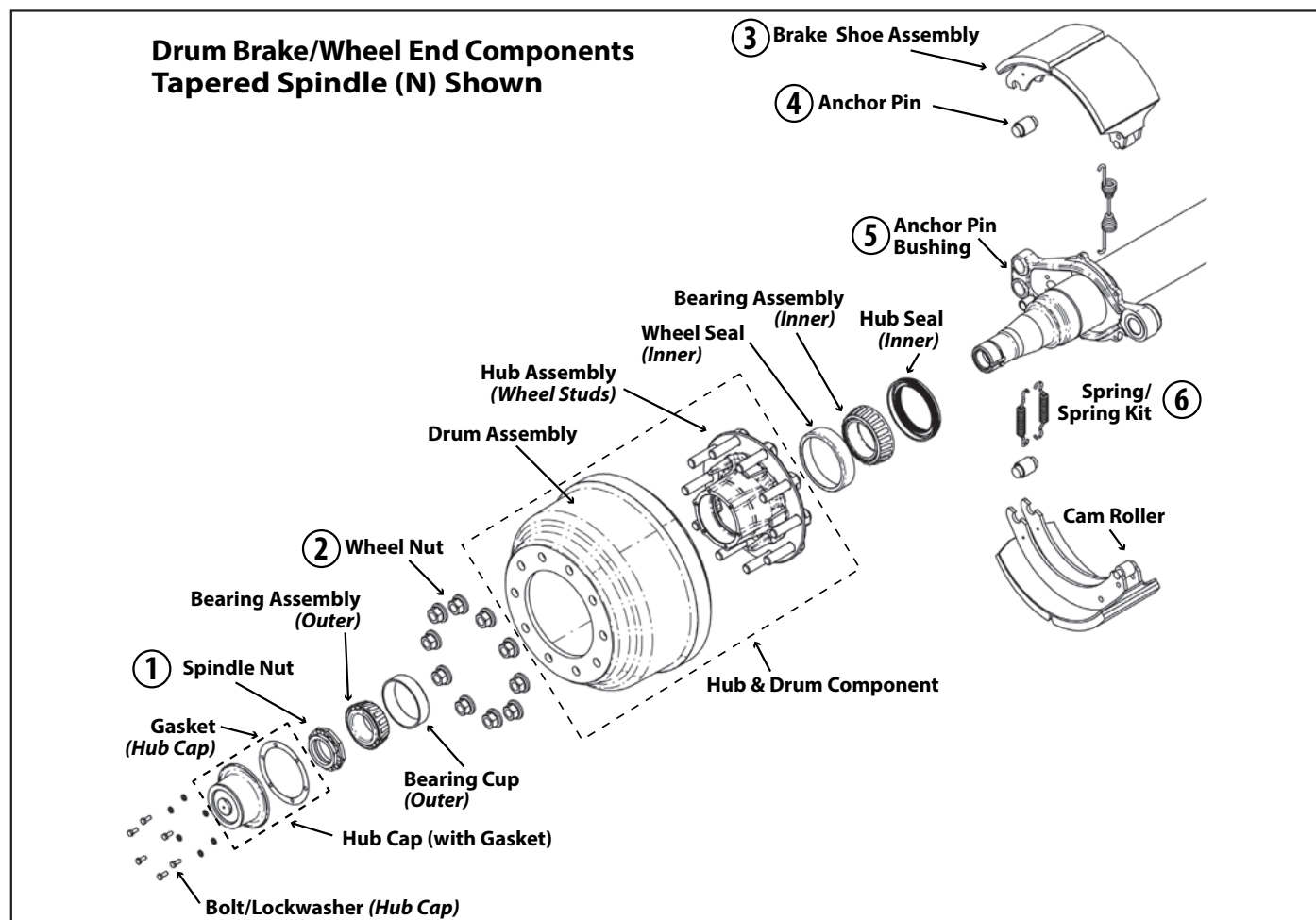

DWG No.	QTY (Per Axle)	Part Number	Item Description
Parallel Spindle (P)			
1	2	1660597	Spindle Nut Kit
	Inc. in Kit	1 1660052	Washer
		1 1660051	Castle nut
		1 1660373	Cotter pin
Tapered Spindle (N)			
1	2	1664206B014	Spindle Nut Kit
	Included in Kit	1 1664206B035	Inner spindle nut
		1 1664206B034	Lock washer
		1 1664206B037	Tab lock washer
		1 1664206B036	Outer nut
2	1660057	Flanged Wheel Nut – M22 x 1.5 x 33 (1.30" x 1.22")	

Drum Brake Assembly –Service Parts					
DWG No.	QTY (Per Axle)	Item Description	16.5" x 7.0" 20K Brake Rating - PL133	16.5" x 7.0" 23K Brake Rating - PL244	12.25" x 7.5" 20K Brake Rating - PL244
3	4	Brake shoe and lining assy - Q+ (includes cam roller and clip)	1667591B305	1667591B306	
		Brake shoe and lining assy - Q (includes cam roller and clip)	1667591B307	1667591B308	1664204B006
4	4	Anchor pin	1667591B010	1667591B010	1667591B010
5	4	Anchor pin bushing			
6	4	Retainer spring	1667591B012	1667591B012	1667591B012
	2	Return spring	1667591B035	1667591B035	1664204B011

Dust Shields				
Part Number	Item Description	Required Fasteners	MFG	Manufacturer Part Number
1667511B005	Dust Shield 16.5x7.0 (18.11" OD 2.83 DP)	1137511B005 (6)	Fuwa	H18-0103
1664204B008	Dust Shield 12.25x7.5 (13.78" OD 2.38 DP)	1137511B005 (4)	Fuwa	H18-0202

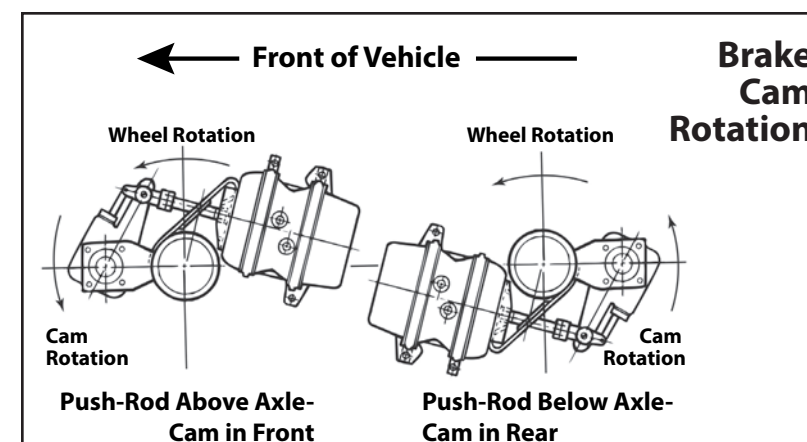

The axle assembly should be installed so that, when the brakes are activated, the camshaft rotates in the same direction as the wheels when the vehicle is moving forward.

Opposite rotation of the camshafts can cause vibrations that can damage components such as the air chambers and chamber brackets attached to the axle.

There are two recommended configurations for axle installations:

- Cams front and air chamber push-rod above the axle.
- Cams rear and air chamber push-rod below the axle.

The decision on which configuration to use is based on obtaining adequate clearance between the axle and other vehicle components, maximizing ground clearance or locating components for maintenance access.

Brake Chamber Mount – Hole Patterns

Drum Brake Chamber Mounting Brackets

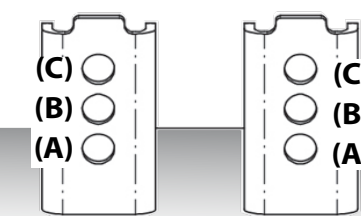

Axle

Brake Size	16.5x7.0"	12.25 x 7.5"
Hole-Code	Slack Adjuster Length	Slack Adjuster Length
A – A	5"	–
B – B	6"	5.5"
B – A	5.5"	5"
B – C	–	6"

Hub Cap							
Spindle	Part Number	Side-Fill Port	MFR Part No.	MFR	Lubrication Type	Vent	
N	1660155	No	352-4009	Stemco	Hard/Semi-Fluid Grease	Duckbill	
	1660346	Yes	348-4009		Oil	Sentinel	
	1664206B006	Yes	343-4009		Oil	Standard	
	1664206B018	No	340-4009		Oil	Standard	
	1664206B029	No	349-4009		Hard/Semi-Fluid Grease	Sentinel	
	1664206B040	Yes	353-4009		Oil	ESP Plug	
P	1660054	Yes	343-4195	Stemco	Oil	Standard	
	1660305	No	349-4195		Hard/Semi-Fluid Grease	Sentinel	
	1660341	Yes	348-4195		Oil	Sentinel	
	1660435	No	352-4195		Hard/Semi-Fluid Grease	Duckbill	

Anti-Lock Brake System (ABS)					
Part Number	Type	MFR Part No.	MFR	Description	
1664702B001	90-Degree	4410328080	Wabco	ABS Sensor (Lead Length - 0.3 meter)	
1664702B003	Straight	4410323340		ABS Sensor (Lead Length - 1 meter)	
1664702B010	Straight	300151	Bendix	ABS Sensor (Lead Length - 1.7 meter)	
1664702B002	Bushing Retainer				

Wheel Bearing					
Spindle	Part Number	Cup or Cone	Location	MFR	Industry Number
N	1664206B008	Cone	Inner	VNC	HM218248 (3.543 ID)
	1664206B009		Outer	VNC	HM212049 (2.625 ID)
	1664206B041		Inner	Hyatt	HM218248
	1664206B042		Outer	Hyatt	HM212049
	1664206B028		Inner	Stemco	KHM218248 (3.543 ID)
	1664206B027		Outer	Stemco	KHM212049 (2.625 ID)
	1664206B032	Cup	Inner	VNC	HM218210
	1664206B033		Outer	VNC	HM212011
P	1660048	Cone	Inner/Outer	VNC	HM518445
	1660304		Inner/Outer	Stemco	KHM518445
	1660502		Inner/Outer	Hyatt	HM518445
	1660527		Inner/Outer	Timken	HM518445
	1660397	Cup	Inner/Outer	VNC	HM518410

Wheel Seal				
Spindle	Part Number	Manufacturer	Type	MFR Part No.
N	1667537B004	Stemco	Guardian HP	307-0743
	1660458	National	Gold PTFE	M380025
P	1660276	Stemco	Guardian HP	307-0723
	1660494	National	Gold PTFE	M386590T

Wheel Bearing Adjustment Procedure

Refer to TMC's Recommended Practice 618 - Wheel Bearing Adjustment Procedure. The procedures should obtain a verifiable wheel bearing end play of 0.001" to 0.005" (0.025 mm to 0.13 mm). The RP-618 procedures are for manually adjusted wheel ends and are not applicable to pre-set or unitized wheel ends.

CAUTION For wheel bearing adjustments on manually adjusted wheel ends, the optimum condition for measuring the end play is with the tires/wheels and brake drum removed from the hub. Always support the vehicle with stands; do not work under a unit supported by only a jack. Block the wheels and make sure vehicle cannot roll before releasing the brakes.

NOTE: Do not use an impact wrench when tightening or loosening spindle nuts during the wheel bearing adjustment procedure.

Double Adjusting Nut System (Figure 5)

- Lubricate the bearing with the same type of lubricant used in the hub assembly.
- While rotating the wheel, torque the adjusting nut (A) to 200 ft-lb (271 N·m).
- Back off the adjusting nut (A) one full turn from the bearing.
- While rotating the wheel, tighten the adjusting nut to a final torque of 50 ft-lb (68 N·m).
- Back off the adjusting nut 1/4-to-1/3 turn. Install lock washer (B) using nearest hole.
- Install the outer jam nut (C). Torque to 200-300 ft-lb (271-407 N·m).
- Check end play – (0.001" to 0.005" [0.025 mm to 0.13 mm]).

Verify that the wheel rotates freely when adjustment is completed.

Single Adjusting Nut System (Figure 6)

- Lubricate the bearing with the same type of lubricant used in the hub assembly.
- Install lock washer (B).
- While rotating the wheel, torque adjusting nut (A) to 200 ft-lb (271 N·m).
- Back off the adjusting nut (A) one full turn from the bearing.
- While rotating the wheel, tighten the adjusting nut to a final torque of 50 ft-lb (68 N·m).
- Back off the adjusting nut 1/6-to-1/4 turn to the nearest locking hole.
- Install cotter pin.
- Check end play – (0.001" to 0.005" [0.025 mm to 0.13 mm]).

Verify that the wheel rotates freely when adjustment is completed.

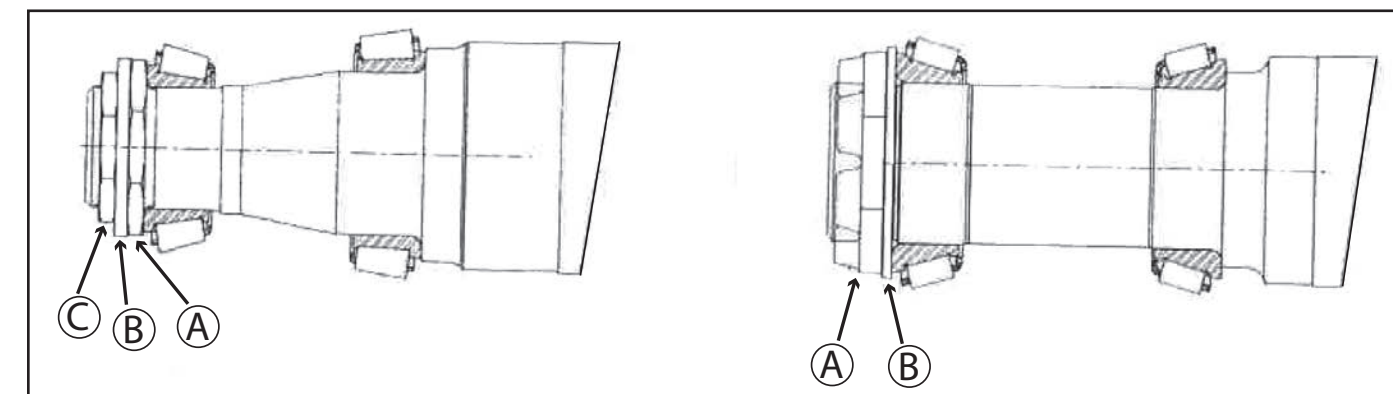
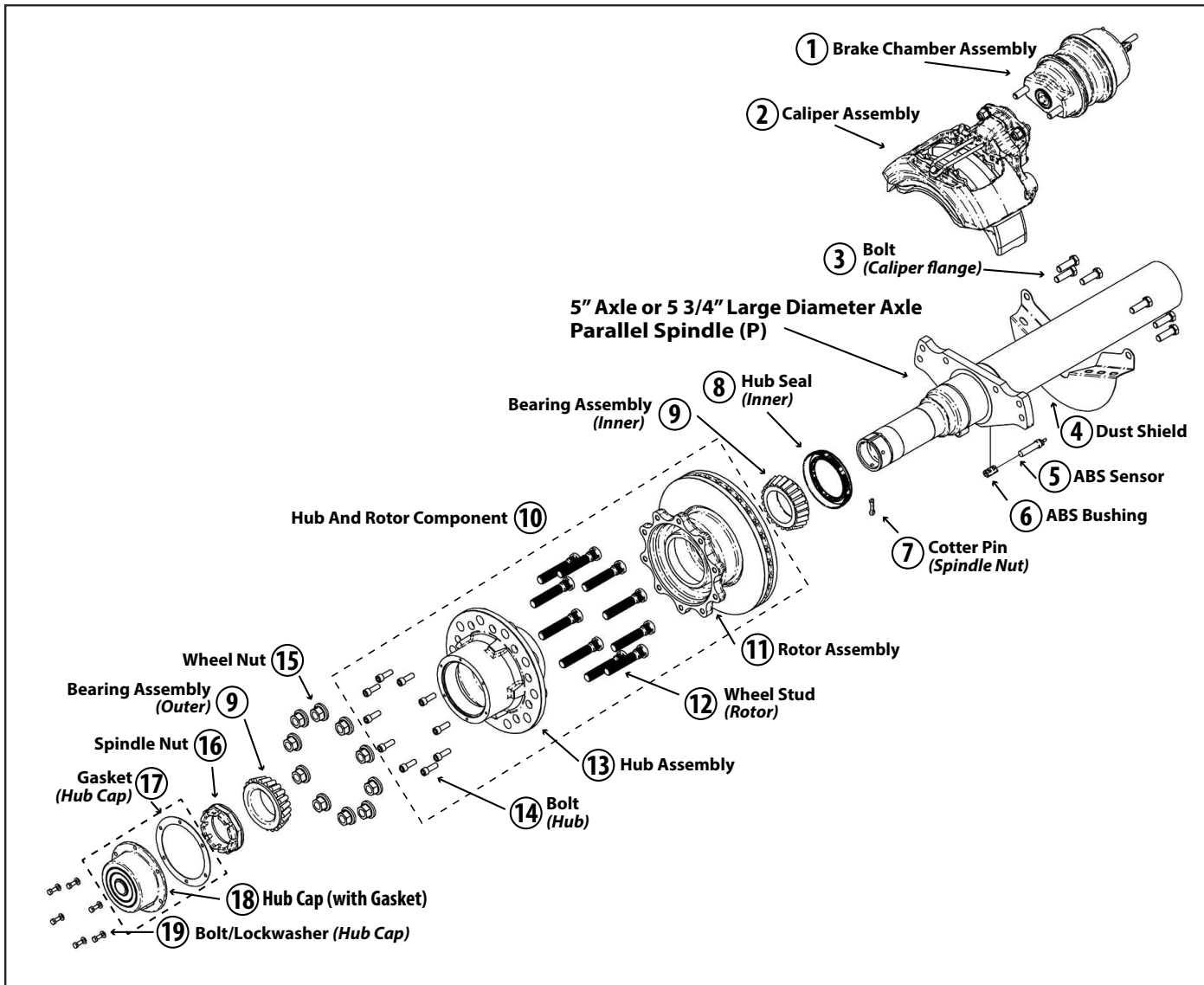

Figure 5.
Double Adjusting Nut System

Figure 6.
Single Adjusting Nut System



See 164-Part Number Descriptions on page 4 for axle identification.

164xxxDxxxx – Wabco Caliper

DWG No.	QTY (Per Axle)	Part No.	Item Description
1	1	1660351	SPG BRK CHMBR ASY (20/24), 45 Deg. (20K brake rating)
	1	1660352	SPG BRK CHMBR ASY (20/24), 135 Deg. (20K brake rating)
	1	1660203	SPG BRK CHMBR ASY (24/24), 45 Deg. (23K brake rating)
	1	1660204	SPG BRK CHMBR ASY (24/24), 135 Deg. (23K brake rating)
	1	1660433	Brake actuator, Service Only, Type 20, 45 Deg. (20K brake rating)
	1	1660434	Brake actuator, Service Only, Type 20, 135 Deg. (20K brake rating)
	1	1660205	Brake actuator, Service Only, Type 24, 45 Deg. (23K brake rating)
	1	1660206	Brake actuator, Service Only, Type 24, 135 Deg. (23K brake rating)
2	1	1660360	Caliper Assembly (Left-Hand)
	1	1660361	Caliper Assembly (Right-Hand)
	1	1660362	Pad Kit, PAN 22 (Not Shown)
3	10	1130045	Hex Head Cap Screw (HHCS) M16-1.5 x 55mm; GR 10.9
	2	1130046	Hex Head Shoulder Cap Screw (HHSCS) M16-1.5 x 55mm; GR 10.9
4	2	1660386	Dust Shield – Pattern 1 - PAN 22
5	2	1664702B003	ABS - Sensor
6	2	1664702B002	ABS - Bushing
7	2	1660373	Cotter Pin (Spindle Nut)
8	2	1660215	Hub Seal (Inner)
9	4	1660304	Bearing Cone - 3.5" ID (Inner/Outer)
10	2	1660359	Hub and Rotor Component (P) Spindle - PAN 22
11	2	1660363	Rotor, PAN 22
12	20	1660083	Wheel Stud - M22 x 1.5; 4.79" length
13	2	1660364	Hub Assembly - (P); 10-Stud (with cups and wheel nuts)
14	20	1130044	Rotor to Hub Fastener M16 - 2 x 35mm; GR 10.9
15	20	1660057	Wheel Nut
16	2	1660597	Spindle Nut (Castle Nut) Kit
17	2	1660055	Gasket (All Hub Caps)
18	2	1660341	Hub Cap with Gasket (Oil Lubrication) – Sentinel Vent
	2	1660054	Hub Cap with Gasket (Oil Lubrication)
	2	1660305	Hub Cap with Gasket (Hard/Semi-Fluid Grease Lubrication)– Sentinel Vent
	2	1660435	Hub Cap with Gasket (Hard/Semi-Fluid Grease Lubrication) – Duckbill Vent
19	12	1144206B105	HHCS 5/16" - 18NC 3/4" length
	12	1164263B100	Lock Washer 5/16"

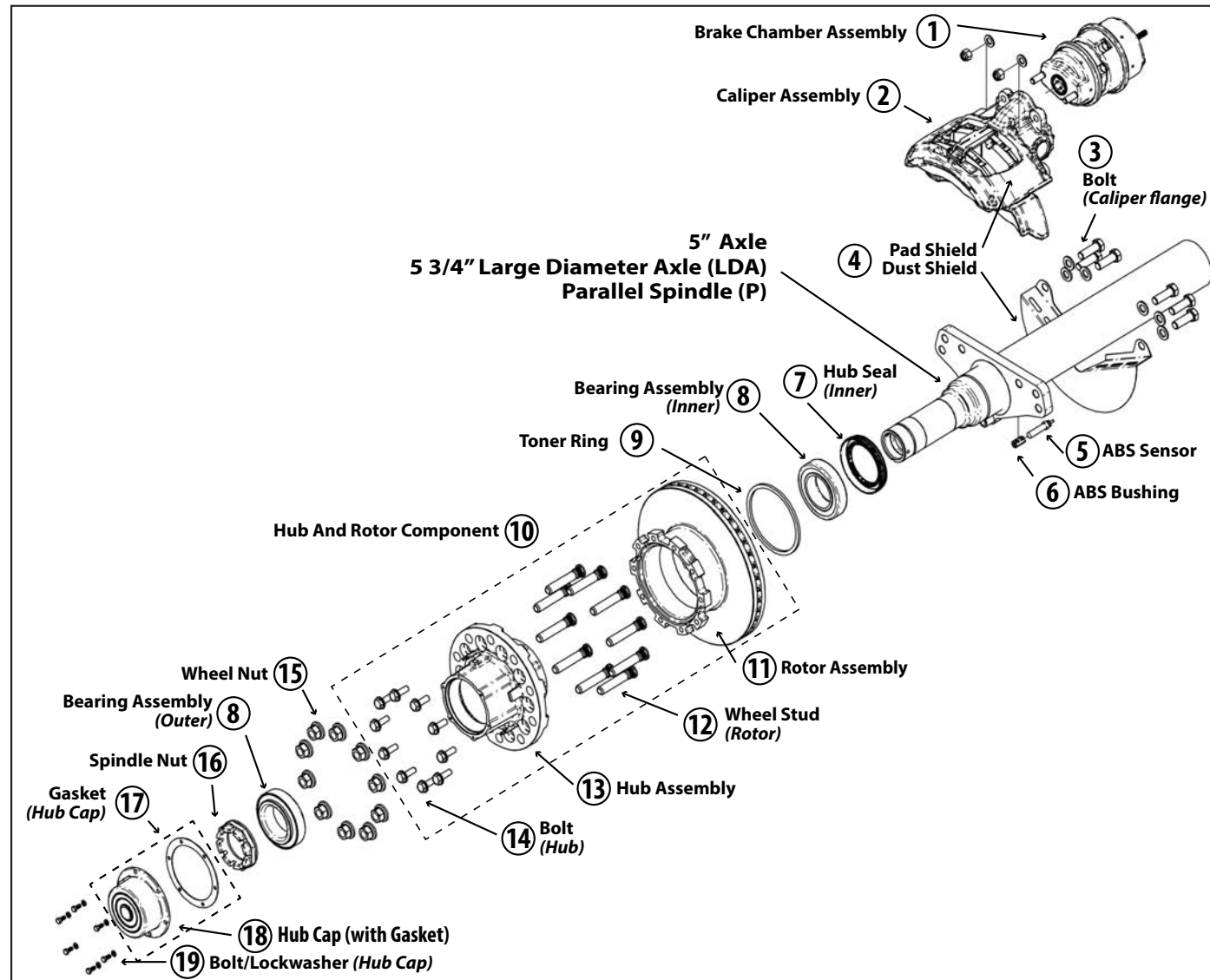

See 164-Part Number Descriptions on page 4 for axle identification.

164xxxWxxxx – Wabco Caliper

164xxxBxxxx – Bendix Caliper

164xxxLxxxx – Bendix Light-Duty Caliper

DWG No.	QTY (Per Axle)	Part No.	Item Description
1	1	1660428	SPG BRK CHMBR ASY - Bendix (18/24) 45 Deg. (20K/23K brake rating)
	1	1660429	SPG BRK CHMBR ASY - Bendix (18/24) 135 Deg. (20K/23K brake rating)
	1	1660351	SPG BRK CHMBR ASY - Wabco (20/24) 45 Deg. (20K brake rating)
	1	1660352	SPG BRK CHMBR ASY - Wabco (20/24) 135 Deg. (20K brake rating)
	1	1660203	SPG BRK CHMBR ASY - Wabco (24/24) 45 Deg. (23K brake rating)
	1	1660204	SPG BRK CHMBR ASY - Wabco (24/24) 135 Deg. (23K brake rating)
	1	1660456	Brake actuator, Service Only, Bendix (Type 18) 40 Deg. (20K/23K brake rating)
	1	1660457	Brake actuator, Service Only, Bendix (Type 18) 140 Deg. (20K/23K brake rating)
	1	1660433	Brake actuator, Service Only, Wabco (Type 20) 45 Deg. (20K brake rating)
	1	1660434	Brake actuator, Service Only, Wabco (Type 20) 135 Deg. (20K brake rating)
	1	1660205	Brake actuator, Service Only, Wabco (Type 24) 45 Deg. (20K brake rating)
	1	1660206	Brake actuator, Service Only, Wabco (Type 24) 135 Deg. (20K brake rating)
2	1	1660401	Bendix, Caliper Assembly (Left-Hand)
	1	1660402	Bendix, Caliper Assembly (Right-Hand)
	1	1660528	Bendix LT, Caliper Assembly (Left-Hand)
	1	1660529	Bendix LT, Caliper Assembly (Right-Hand)
	1	1660403	Wabco, Caliper Assembly (Left-Hand)
	1	1660404	Wabco, Caliper Assembly (Right-Hand)
	1	1660442	Pad Kit, Bendix ADB22X (Not Shown)
	1	1660546	Pad Kit, Bendix ADB22X-LT (Not Shown)
3	12	1140087	Hex Head Cap Screw (HHCS) M20-2.5x60mm; GR 10.9
	12	1160025	Flat Washer (M20)
4	2	1660422	Dust Shield
	2	1660479	Pad Shield - Bendix (Caliper Only)
5	2	1664702B003	ABS-Sensor (Wabco)
	2	1664702B010	ABS-Sensor (Bendix)
6	2	1664702B002	ABS-Bushing (Wabco or Bendix)

Pattern 2 Axle components continued on next page

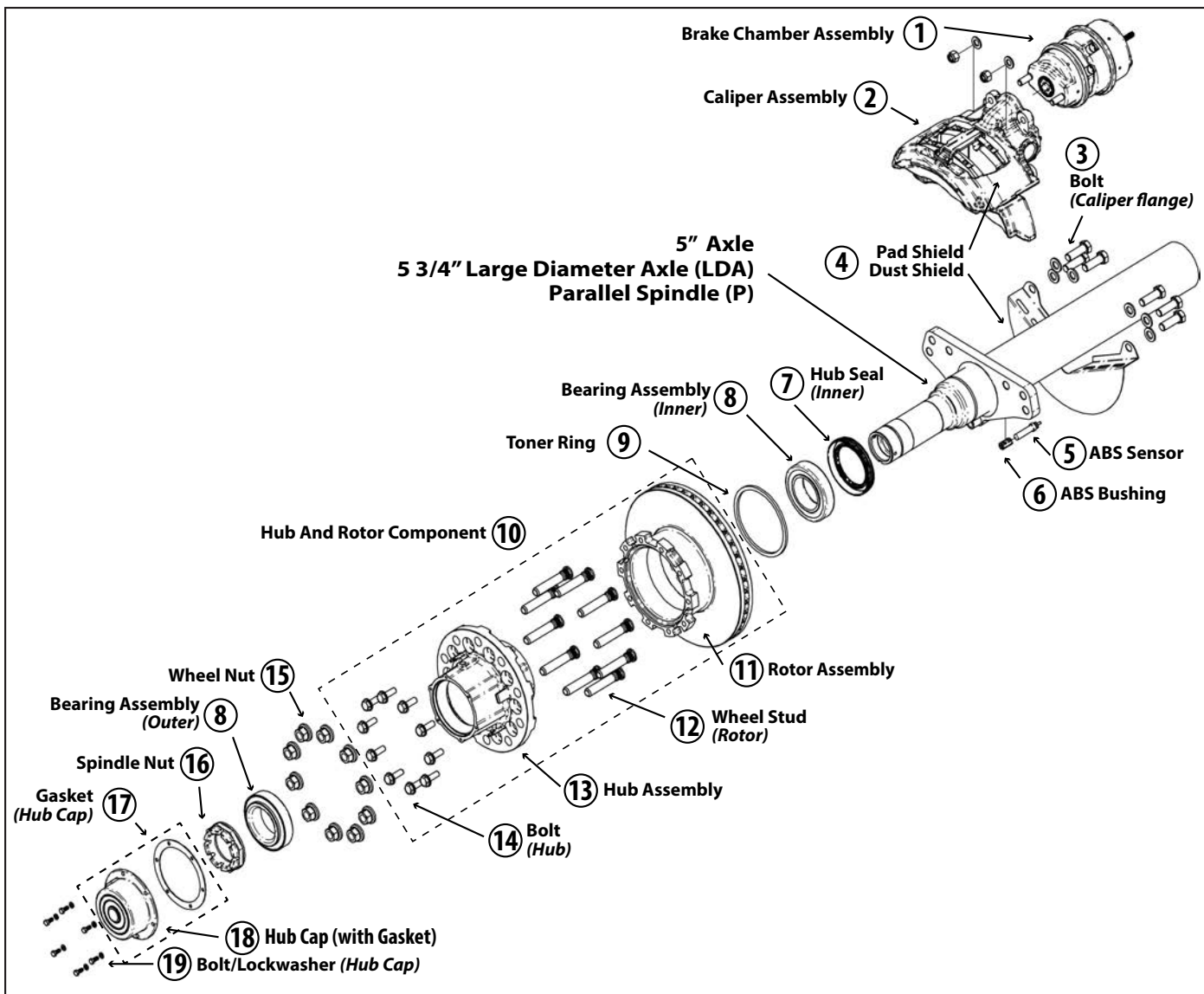

See 164-Part Number Descriptions on page 4 for axle identification.

164xxxWxxxx – Wabco Caliper

164xxxBxxxx – Bendix Caliper

164xxxLxxxx – Bendix Light-Duty Caliper

Pattern 2 Axle components - continued

DWG No.	QTY (Per Axle)	Part No.	Item Description
7	2	1660494	Hub Seal (Inner)-National Gold PTFE
	2	1660276	Hub Seal (Inner))-STEMCO Guardian® HP
8	4	1660304	Bearing Cone - 3.5" ID (Inner/Outer)
	2	1660441	Tone Ring-ABS ring kit (ConMet® Hub 1660405/1660356-before 04/01/2018)
	2	1660604	Tone Ring-ABS ring kit (ConMet Hub 1660405/1660356-04/01/2018-03/01/2019)
9	2	1660615	Tone Ring-ABS ring kit (ConMet Hub 1660405/1660356-after 03/01/2019)
	2	1660400	Gunite® Hub, Rotor, and Tone Ring Assembly, Cast/Cast
	2	1660603	KIC - Hub and Rotor FP (Integral Tone Ring)
10	2	1660405	ConMet Hub, Rotor, and Tone Ring Assembly, AL/Cast
	2	1660356	ConMet PreSet® Hub, Rotor, and Tone Ring Assembly, AL/Cast
	2	1660552	Walther EMC-Hub, Rotor, and Tone Ring Assembly, ADI/Cast
	2	1660439	Gunite-Rotor Only (Integral Tone Ring)
11	2	1660440	ConMet (Standard/PreSet) Rotor Assembly (Integral Tone Ring)
	2	1660614	KIC-Rotor Only (Integral Tone Ring)
	2	1660554	Walther EMC-Rotor Kit (Integral Tone Ring)
12	20		Wheel studs - Gunite
	20		Wheel studs - ConMet (Standard and PreSet)
	20	1660083	Wheel studs - KIC
	20	1660553	Wheel studs - Walther EMC
13		Not Available	Conmet; Gunite; KIC - Hub Only
	2	1660555	Walther EMC - Hub only
14	20		Flanged Nut (5/8" - 18) - Rotor to Hub; Conmet (Standard and PreSet)
	20	1140092	Bolts - Rotor to Hub; Gunite (5/8" - 11)
	20	1160029	Washers - Rotor to Hub; Gunite (5/8")
	20		Bolt - Rotor to Hub; KIC (M16 x 2 x 45 HHCS)
	20		Washer - Rotor to Hub; KIC (M16; Hardened)
	20		Bolts/Washers - Rotor to Hub; Walther EMC
	20		
15	20	1660057	Wheel Nut
16	2	1660597	Spindle Nut (Castle Nut) Kit
17	2	1660055	Gasket (Hub Cap)
18	2	1660341	Hub Cap with Gasket (Oil Lubrication) - Sentinel Vent
	2	1660054	Hub Cap with Gasket (Oil Lubrication)
	2	1660305	Hub Cap with Gasket (Hard/Semi-Fluid Grease Lubrication) - Sentinel Vent
	2	1660435	Hub Cap with Gasket (Hard/Semi-Fluid Grease Lubrication)- Duckbill Vent
19	12	1144206B105	HHCS 5/16" - 18NC 3/4" length
	12	1164263B100	Lock Washer 5/16"

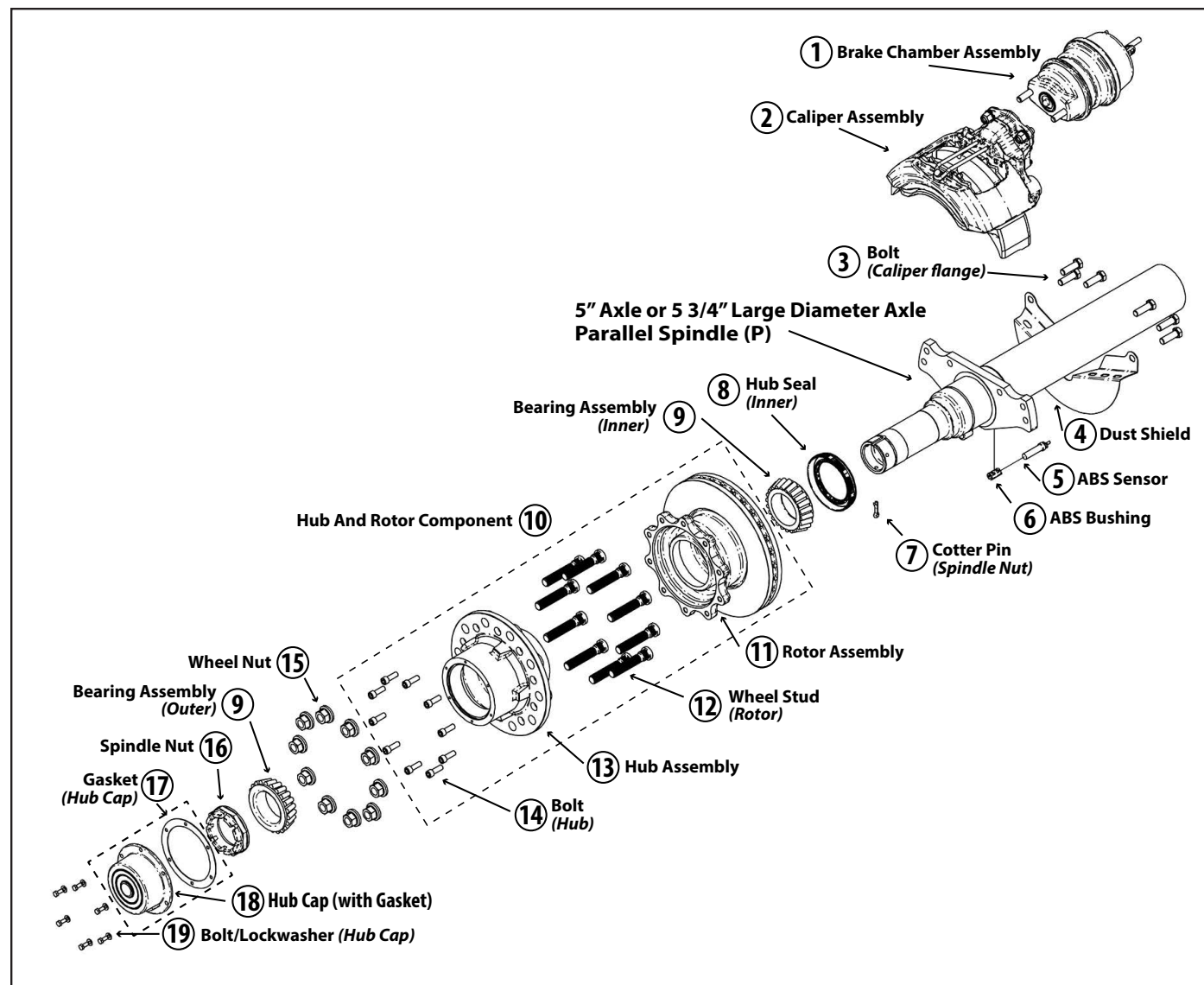

See 164-Part Number Descriptions on page 4 for axle identification.

164xxxPxxxx - Wabco Caliper

DWG No.	QTY (Per Axle)	Part No.	Item Description
1	1	1660428	SPG BRK CHMBR ASY (18/24), 45 Deg. (20K/23K brake rating)
	1	1660429	SPG BRK CHMBR ASY (18/24), 135 Deg. (20K/23K brake rating)
	1	1660351	SPG BRK CHMBR ASY, (20/24), 45 Deg. (20K brake rating)
	1	1660352	SPG BRK CHMBR ASY, (20/24), 135 Deg. (20K brake rating)
	1	1660203	SPG BRK CHMBR ASY, (24/24), 45 Deg. (23K brake rating)
	1	1660204	SPG BRK CHMBR ASY, (24/24), 135 Deg. (23K brake rating)
	1	1660456	Brake actuator, Service Only, Type 18, 40 Deg.
	1	1660457	Brake actuator, Service Only, Type 18, 140 Deg.
	1	1660433	Brake Actuator, Service Only, Type 20, 45 Deg.
	1	1660434	Brake Actuator, Service Only, Type 20, 135 Deg.
2	1	1660205	Brake Actuator, Service Only, Type 24, 45 Deg.
	1	1660206	Brake Actuator, Service Only, Type 24, 135 Deg.
	1	1660467	Caliper Assembly (Left-Hand)
3	1	1660468	Caliper Assembly (Right-Hand)
	1	1660496	Pad Kit, PAN 19 (Not Shown)
	12	1130058	(5" Axle) Hex Head Cap Screw (HHCS) M16x1.5 x 50mm; GR 10.9
4	10	1130056	(LDA) Hex Head Cap Screw (HHCS) M16-1.5 x 59mm; GR 10.9
	2	1130057	(LDA) Hex Head Shoulder Cap Screw (HHSCS) M16-1.5 x 59mm; GR 10.9
5	2	1660500	Dust Shield
6	2	1664702B003	ABS - Sensor
7	2	1664702B002	ABS - Bushing
8	2	1660373	Cotter Pin (Spindle Nut)
9	2	1660494	Hub Seal (Inner) - National Gold PTFE
	2	1660276	Hub Seal (Inner) - STEMCO Guardian® HP
10	2	1660304	Bearing Cone-3.5" ID (Inner/Outer)
11	2	1660466	Hub and Rotor Component (FP) - PAN 19
12	16	1660083	Wheel Stud - M22 x 1.5; 4.79" length
13		Not Avail.	PAN 19 Hub Only, Cast
14	10	1660083	Socket Head Cap Screw (SHCS) M12 x 1.75 35mm; GR 12.9
15	20	1660057	Wheel Nut
16	2	1660597	Spindle Nut (Castle Nut) Kit
17	2	1660055	Gasket (Hub Cap)
18	2	1660341	Hub Cap with Gasket (Oil Lubrication) - Sentinel Vent
	2	1660054	Hub Cap with Gasket (Oil Lubrication)
	2	1660305	Hub Cap with Gasket (Hard/Semi-Fluid Grease Lubrication) - Sentinel Vent
	2	1660435	Hub Cap with Gasket (Hard/Semi-Fluid Grease Lubrication) - Duckbill Vent
19	12	1144206B105	HHCS 5/16" - 18NC 3/4" length
	12	1164263B100	Lock Washer 5/16"

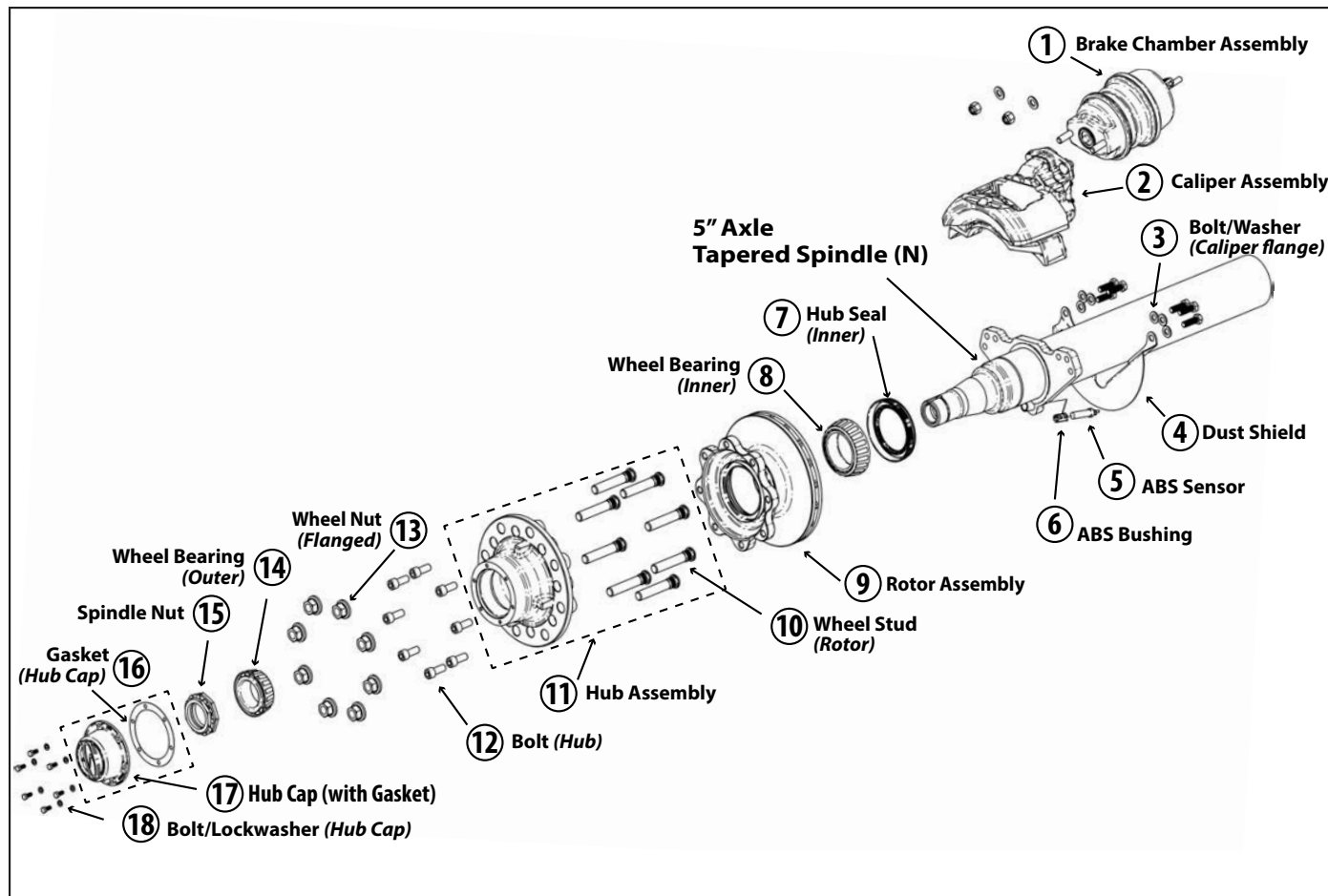

See 164-Part Number Descriptions on page 4 for axle identification.

164xxxSxxxx – Wabco Caliper

DWG No.	Qty (Per Axle)	Part No.	Item Description
1	1	1660351	SPG BRK CHMBR ASY, (20/24), 45 Deg. (20K brake rating)
	1	1660352	SPG BRK CHMBR ASY, (20/24), 135 Deg. (20K brake rating)
	1	1660433	Brake actuator, Service Only, Type 20, 45 Deg.
	1	1660434	Brake actuator, Service Only, Type 20, 135 Deg.
2	1	1660462	Caliper Assembly (Left-Hand)
	1	1660463	Caliper Assembly (Right-Hand)
	1	1660497	Pad Kit, PAN 17 (Not Shown)
3	12	1140093	Hex Head Cap Screw (HHCS) M14-1.5 X 45mm; GR 10.9
	12	1160030	Flat Washer, M14
4	1	1660503	Dust Shield
5	2	1664702B010	ABS-Sensor
6	2	1664702B002	ABS-Bushing
7	2	1660458	(Inner) Hub Seal - National Gold PTFE
8	2	1664206B008	(Inner) Wheel Bearing Cone (3.543" ID)
9	2	1660487	Rotor 325mm X 34mm, PAN 17
10	16	1660083	Wheel Stud M22x1.5; 4.79" length
11	2	1660488	Hub Assembly - FN, PAN 17
12	16	1130059	Socket Head Cap Screw (SHCS) M16-2.0 X 40mm
13	16	1660057	Flanged Wheel Nut – M22 x 1.5 (Torque to 450-500 ft-lb)
14	2	1664206B009	(Outer) Wheel Bearing (2.625 ID)
15	2	1664206B014	Spindle Nut Kit
16	2	1664206B007	Gasket (Hub Cap)
	2	1660155	Hub Cap w/ Gasket (Hard/Semi-Fluid Grease Lubrication) - Duckbill Vent
17	2	1664206B006	Hub Cap w/ Gasket (Oil Lubrication) - Sentinel Vent
	2	1660155	Hub Cap w/ Gasket (Hard/Semi-Fluid Grease Lubrication) - Duckbill Vent
18	12	1144206B105	HHCS 5/16" - 18NC 3/4" length
	12	1164263B100	Lock Washer 5/16"

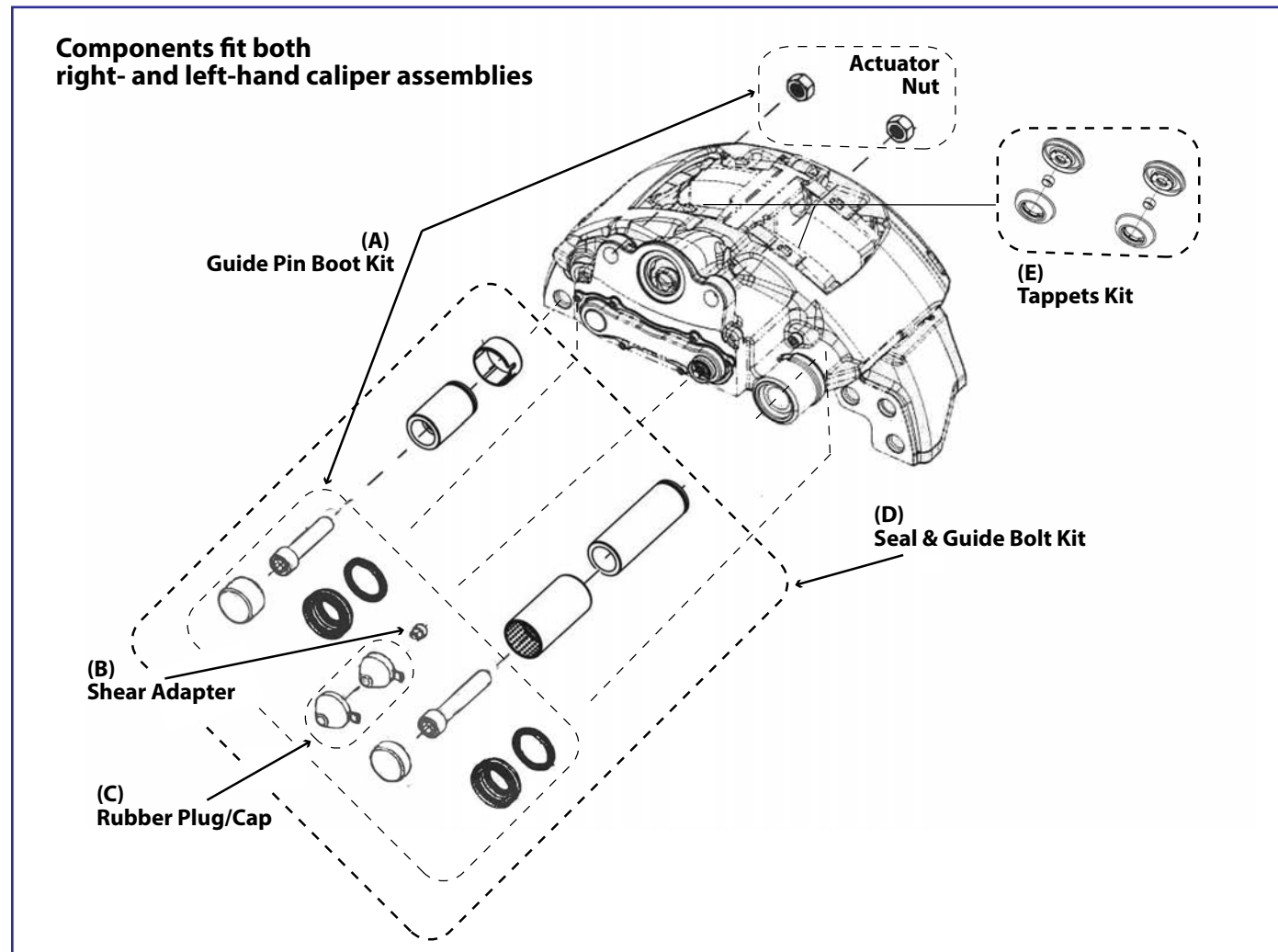

Dwg No.	Qty per Axle	Part Number	Description
A	1	1660446	Guide Pin Boot Kit
B	2	1660451	Shear Adapter
C	2	6040148	Rubber plug
D	2	1660443	Seal & Guide Bolt Kit
E	2	1660445	Tappets Kit (includes tappet and boot)

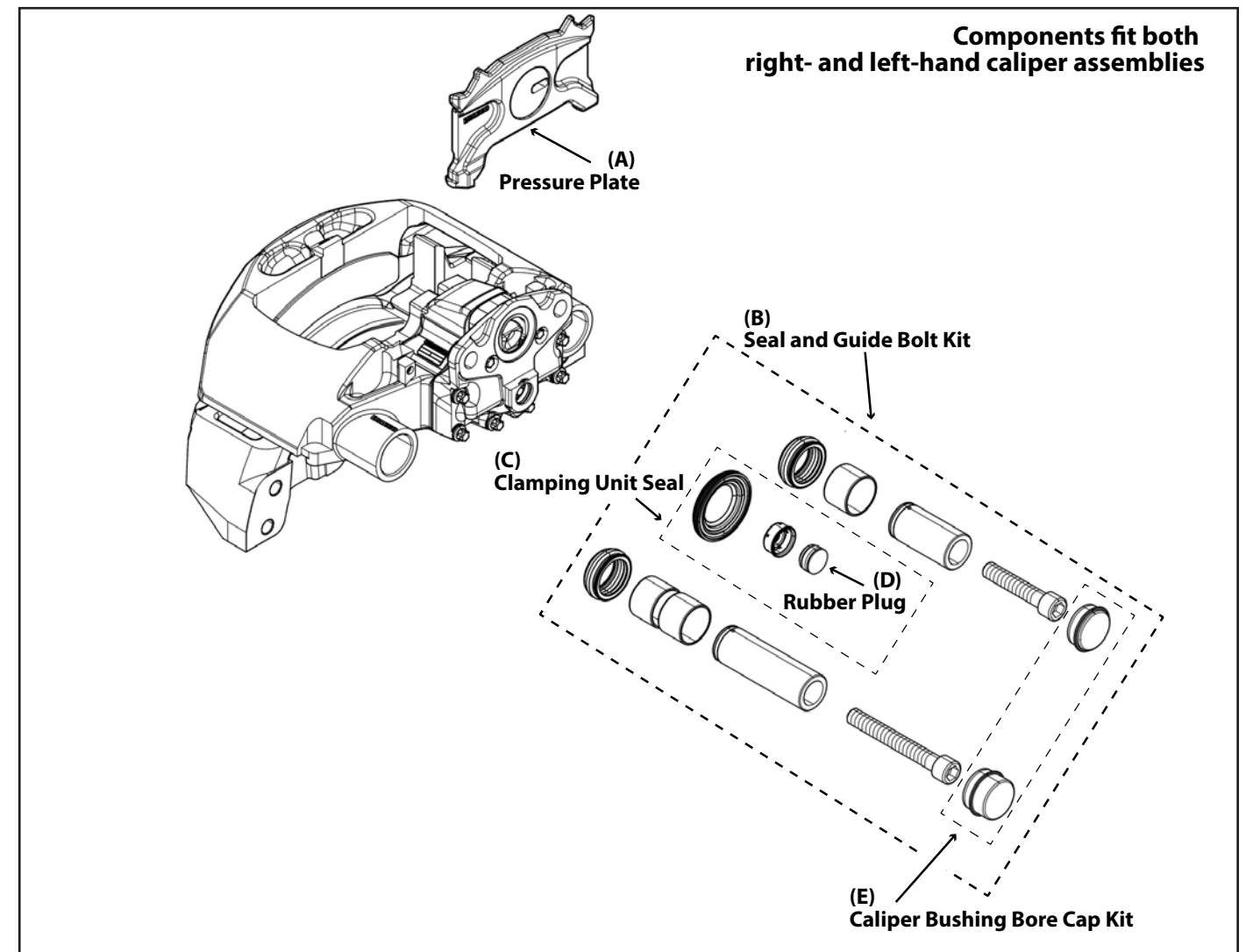

Dwg No.	Qty per Axle	Part Number	Description
A	2	1660557	Pressure Plate – PAN 17
	2	1660558	Pressure Plate – PAN 19
	2	1660559	Pressure Plate – PAN 22
B	2	1660498	Seal and Guide Bolt Kit – PAN 17
	2	1660390	Seal and Guide Bolt Kit – PAN 22
C	2	1660612	Seals for Clamping Unit – PAN 17; PAN 19; PAN 22
D	2	1660365	Rubber (Gaiter) Plug – PAN 17; PAN 19; PAN 22
E	1	1660541	Caliper Bushing Bore Cap Kit – PAN 19; PAN 22
	1	Not Avail.	PAN 17 Tool kit – (Wabco - 6401755212)
	1	6100068	PAN 19; PAN 22 Tool kit (Basic)
	1	6100078	PAN 19; PAN 22 Tool kit

Axle/Wheel End Components-Torque Specifications

Axle/Wheel End Components – Torque Specifications*			
Component Type	Component Description	foot-pound	Newton-meter
Spindle Nut	See Wheel Bearing Adjustment Procedure		
Brake Chamber Mounting Fastener	5/8" Mounting Hardware	110-150 ft-lb	149-203 N-m
ADB Hub-to-Rotor Fastener (Locknut required)	Ridewell Pattern One – Cast Iron Hub	229-258 ft-lb	310-350 N-m
	Gunite® Pattern Two – Cast Iron Hub	210-230 ft-lb	285-312 N-m
	ConMet® Pattern Two – Aluminum Hub	180-210 ft-lb	244-285 N-m
	Wabco PAN™ 19 – Pattern Three/Four	100-103 ft-lb	135-140 N-m
	Wabco PAN™ 17 – Pattern Five	180-200 ft-lb	248-272 N-m
ADB Caliper Mounting Fasteners	Wabco PAN™ 22 – Pattern One	199-229 ft-lb	270-310 N-m
	Wabco PAN™ 22 – Pattern Two	342-395 ft-lb	464-536 N-m
	Wabco PAN™ 19 – Pattern Three/Four	199-229 ft-lb	270-310 N-m
	Wabco PAN™ 17 – Pattern Five	118-148 ft-lb	160-200 N-m
	Bendix ADB22X™/22X-LT™ – Pattern Two	Step 1 Pre-Torque: 20-60 ft-lb	27-81 N-m
	Step 2 Final: 350-400 ft-lb	475-542 N-m	
Automatic Slack Adjuster -to-Push Rod	Jam nut – pushrod-to-clevis	(5/8-18) 400 in-lb	45.19 N-m
Wheel Nut Hub-Piloted - Flanged Stud-Piloted-Ball-Seat	M22 x 1.5 x 33 (1.30" x 1.22") 3/4" x 16	450-500 ft-lb	610-678 N-m
		450-500 ft-lb	610-678 N-m
Do not use motor-driven screw or torque tools on hub cap fasteners.			
Hub Cap Bolt	HHCS 5/16 18NC 3/4" long / Lock Washer	12-16 ft-lb (144-192 in-lb)	16-22 N-m

*Refer to original equipment manufacturer for complete torque specifications.

CAUTION Failure to install/maintain fasteners at torque could result in suspension failure and void warranty.

Ridewell suggests the Technology & Maintenance Council (TMC) publications for additional information.

TMC RP 222	User's Guide to Wheels and Rims
TMC RP 604	Brake Chambers for Air-Braked Vehicles
TMC RP 607	Preventive Maintenance and Inspection of S-Cam Foundation Brakes
TMC RP 608	Brake Drums and Rotors
TMC RP 609	Self-Adjusting and Manual Brake Adjuster Removal, Installation and Maintenance
TMC RP 618	Wheel Bearing Adjustment Procedure
TMC RP 619	Air System Inspection Procedure
TMC RP 622	Wheel Seal and Bearing Removal, Installation and Maintenance
TMC RP 631	Recommendations for Wheel End Lubrication
TMC RP 651	Steer Axle Maintenance Guidelines
TMC RP 652	Service and Inspection of Air Disc Brakes
TMC RP 656	Hub and Spoke Wheel Fastener Maintenance
TMC RP 708	Trailer Axle Alignment
TMC RP 728	Trailer Axle Maintenance
TMC RP 1503	Brake Maintenance Guidelines for Severe Vocational Applications
TMC RP 1506	Torque Rod Maintenance Guidelines for Vocational Vehicles
TMC RP 1509	Drive Axle Suspension Maintenance and Inspection Guidelines for Vocational Vehicles

Ridewell Suspensions recommends the following minimum service intervals for standard duty, on-highway usage suspension applications. More frequent intervals are recommended for heavier duty applications.

Daily/Pre-Trip Inspections

- ___ Check tires for proper inflation, damage/excessive wear.
- ___ Check oil-level in wheel hub and inspect wheel-ends for obvious signs of lubricant leakage. Check suspension and wheel ends for missing components.
- ___ Visually inspect suspension structure for signs of damage or excessive wear.
- ___ Check for loose/missing bolts/nuts. Check suspension components for irregular movement.
- ___ Make sure air controls are operating properly. Drain all moisture from air reservoirs.

S-Cam Lubrication

The S-Cams will wear if not lubricated properly. Extended wear in the bushing area, flat spots on the cam head or distorted splines will require a cam replacement.

You should clean each grease fitting and the surrounding area before lubricating any vehicle component. Lubricate the S-Cam support bushing grease fittings with #2 EP NLGI chassis lube.

Standard Cam Axle – Add lubricant to both grease fittings until fresh grease can be seen purging from each bushing cavity. Wipe away the excess grease.

Covered-Cam Axle – Add lubricant to the spider-end grease fitting until grease can be seen purging from the slack adjuster-end of the cover. Wipe away the excess grease.

S-Cams should be lubricated monthly. More frequent service intervals may be needed in some applications.

Preventive Maintenance

First 6,000 miles of use

- ___ Torque all component bolts/nuts to specifications (Refer to Manufacturer's Specifications).

Every 12,000 miles of use

- ___ Inspect air springs for damage or excessive wear.
- ___ Torque air spring bolts/nuts to specifications (Refer to Manufacturer's Specifications).
- ___ Check air lines and connections for leaks.

Every 50,000 miles of use

- ___ Torque all component bolts/nuts to specifications (Refer to Manufacturer's Spec.).
- ___ Lube camshaft bushings/brake adjusters.

Annually/100,000 miles of use

- ___ Inspect pivot connection for worn pivot bushing and wear washers. Replace as necessary. Torque suspension component bolts/nuts to specifications (Refer to Manufacturer's Spec.).
- ___ Check arm beam-to-axle welds.
- ___ Check lubrication level in wheel ends:
 - 1) Oil-Filled Wheel Ends: Refill/Replace lubricant as needed (RP 631 "100K/Annual Inspection").
 - 2) Semi-Fluid Grease: Pull outer bearing and visually inspect lubrication level. Replace as needed (RP 631 "Level 3 Lubrication Level Inspection" and RP 618 "Wheel Bearing Adjustment Procedure").
- ___ Check air lines/connections for leaks.
- ___ Check disc/drum brake air chambers and slack adjusters.
- ___ Inspect brake rollers, roller shafts, anchor pins and bushings. Replace, if necessary.
- ___ Check shoes for bent shoe ribs, cracks in shoe table welds or ribs, and elongated rivet holes. Replace shoes, if necessary.

CAUTION Failure to torque the bolts/nuts of suspension components to specifications can result in failure of the suspension and voiding of the warranty.

Brake Chamber Part Number for Ridewell Suspensions Listed by Ports Location After Standard Installation*
(RAR-251 and RT-201 Suspensions not included. Not all chamber combinations are available for each suspension type)

Chamber Port Away from Axle - Long Pin Side		
RCA-215/215T	Truck and Trailer	
ADB Chamber Size	Chmbr Part # - Driver's Side	Chmbr Part # - Curb Side
**T-16	1660452	
T-18	1660457	1660456
T-20	1660434	1660433
T-24	1660205	1660206
16/24	1660581	1660580
18/24	1660428	1660429
18/24	1660567	1660566
20/24	1660351	1660352
24/24	1660203	1660204

Port Away From Axle - Short Pin Side		
2400209	Yoke	
RUL-245-245T	Truck and Trailer	
ADB Chamber Size	Chmbr Part # - Driver's Side	Chmbr Part # - Curb Side
**T-16	1660452	
T-18	1660456	1660457
T-20	1660433	1660434
T-24	1660206	1660205
16/24	1660580	1660581
18/24	1660429	1660428
18/24	1660566	1660567
20/24	1660352	1660351
24/24	1660204	1660203

Chamber Port Towards Axle - Long Pin Side		
RAR-240	Overslung, Underslung, Yoke	
RAR-260/200	Overslung	
RAR-266	Overslung	
RSS-233/233T	Truck and Trailer	
Chamber Size	Chmbr Part # - Driver's Side	Chmbr Part # - Curb Side
**T-16	1660452	
T-18	1660456	1660457
T-20	1660433	1660434
T-24	1660206	1660205
16/24	1660580	1660581
18/24	1660429	1660428
18/24	1660566	1660567
20/24	1660352	1660351
24/24	1660204	1660203

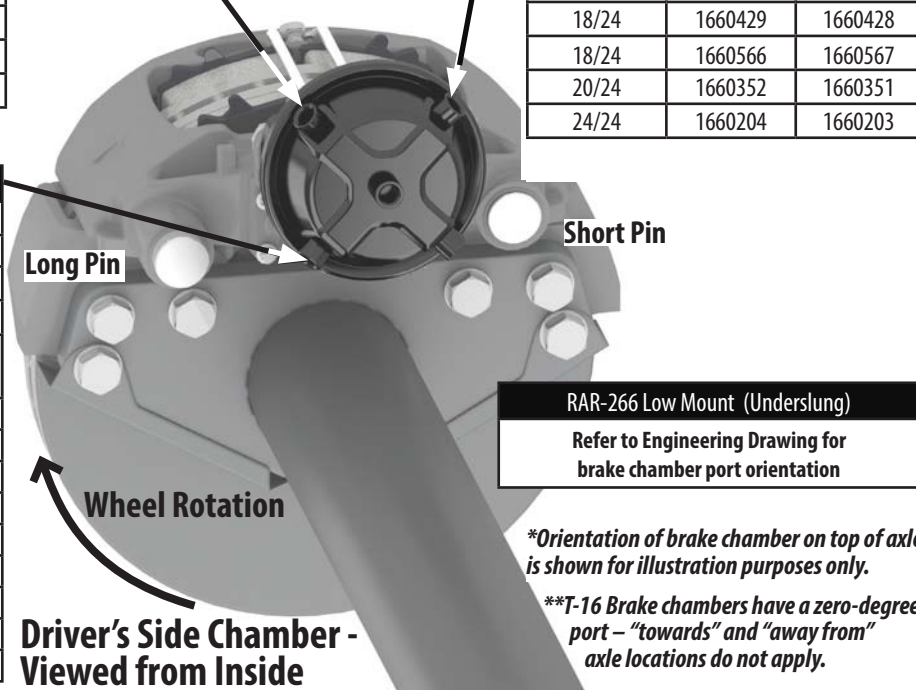

Replacement of a disc brake chamber and its integration into the vehicle's air system depends upon which side of the axle that the brake assembly is to be installed, and the location of the brake chamber ports – either towards or away from the axle.

In some cases, the correct brake assembly for the left-hand (driver's side) or the right-hand (curb side) side of the axle will be indicated by an arrow on the caliper. The brake disc's direction of rotation during forward driving can be found by looking for the Long ("Fixed Position") Pin on the caliper. The wheel rotates forward (towards) past the long pin to the Short ("Floating Position") Pin.

In addition to showing wheel rotation, the location of the ADB chamber ports in relation to the axle (towards or away) will be indicated by the short or long pin (side) of the brake caliper.

Refer to the Technology & Maintenance Council (TMC) Recommended Practices "RP-604 Brake Chambers for Air-Braked Vehicles" and "RP-652 Service and Inspection of Air Disc Brakes" for maintenance/replacement information.

ATIS Installations offered by Ridewell

Pressure Systems International (P.S.I.®) ThermAlert®
www.psitireinflation.com

- Sales Literature
 - MTIS by P.S.I. Brochure
 - Service Literature
 - Maintenance and Install Manual
 - Parts Book
 - How to maintain MTIS by P.S.I.
 - How to adjust the Control Box
 - Driver's Literature
 - Driver's Checklist
- (www.psitireinflation.com/resources#downloads)

ATIS Axle Installation – Preparation Options

Basic (1-Hole)	One 1/8" NPT hole drilled and tapped in the top center of the axle.* Includes Plug.
Fully Prepped	Basic axle preparation plus wheel-end component drill/tap and ATIS air-fittings installation. Air system connection hoses not included.

Aeris® Tire Inflation System Standard or SmartSense®
www.stemco.com

- Sales Literature
 - Aeris Tire Inflation System (Brochure-571-3183)
 - Aeris with SmartSense (Brochure-571-3086)
 - Service Literature
 - Installation/Service Guide
 - Aeris Replacement Parts Guide
- (www.stemco.com/product/automatic-tire-inflation-system)

ATIS Axle Installation – Preparation Options

Basic (3-Hole)	Three 1/4" NPT holes drilled and tapped in the top of the axle (10" spacing).* Includes Plugs.
Fully Prepped	Basic axle preparation plus wheel-end component drill/tap and ATIS air-fittings installation. Air system connection hoses not included.

*Note: Do not use a drill for tapping. The use of a drill to tap holes can lead to breaking the tap or the threads being too deep inside the axle.

An automatic tire inflation system (ATIS) is designed to monitor and maintain the correct air pressure inside the tires on a vehicle.

ATIS Operation

The automatic tire inflation system redirects air from the vehicle's air system to maintain the proper air pressure in the tires. A monitor system reports real-time tire-pressure information to the driver with a low-pressure warning light.

Advantages of an ATIS

Extended Tire Life: Under-inflated tires are the main cause of tire failure and contribute to tire disintegration, heat buildup, ply separation and sidewall/casing breakdowns. In addition, tires that are properly inflated improve fuel economy while adding greater stability, handling and braking efficiencies for increased vehicle safety on the road.

Contact Ridewell Customer Service for the axle and wheel-end preparation needed for a single- or dual-wheel ATIS system.

Terms and coverage in this warranty apply only to the United States and Canada.

Ridewell Suspensions warrants the suspension systems manufactured by it to be free of defects in material and workmanship. Warranty coverage applies only to suspensions that have been properly installed, maintained and operated within the rated capacity and recommended application of the suspension. The responsibility for warranty coverage is limited to the repair/replacement of suspension parts. The liability for coverage of purchased components is limited to the original warranty coverage extended by the manufacturer of the purchased part.

All work under warranty must have prior written approval from the Ridewell warranty department. Ridewell has the sole discretion and authority to approve or deny a claim and authorize the repair or replacement of suspension parts. All parts must be held until the warranty claim is closed.

Parts that need to be returned for warranty evaluation will be issued a Returned Materials Authorization (RMA). Parts must be returned to Ridewell with the transportation charges prepaid. The transportation charges will be reimbursed if the warranty claim is approved.

This non-transferable warranty is in lieu of all other expressed or implied warranties or representations, including any implied warranties of merchantability or fitness or any obligations on the part of Ridewell. Ridewell will not be liable for any business interruptions, loss of profits, personal injury, any costs of travel delays or for any other special, indirect, incidental or consequential losses, costs or damages.

Contact the Ridewell Warranty Dept. at 417.833.4565 - Ext. 135, for complete warranty information.