

# **RSS-233 8K** *Truck* **Self-Steering Auxiliary Axle Suspension** *Lightweight Without Sacrificing Durability*

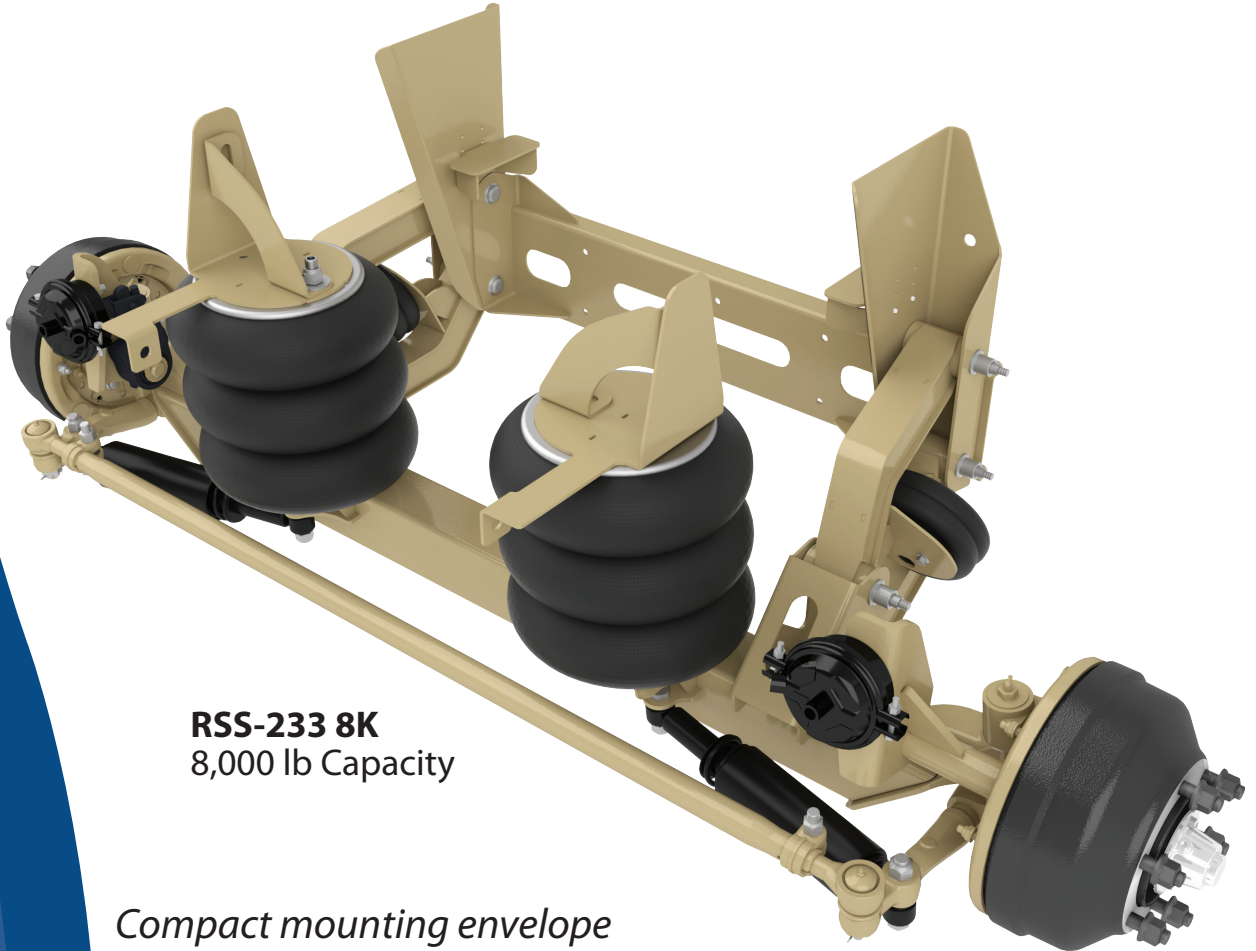

**RSS-233 8K**  
8,000 lb Capacity

*Compact mounting envelope*

*Assembled with Huck® fasteners for reduced maintenance*

*13" total travel, maximum of 10" lift*

*Pre-plumbed air tank available*

*Lightweight*

*5 year limited warranty*



# RSS-233 8K *Truck*

## *Self-Steering Auxiliary Axle Suspension*

### Features

#### *Industry Standard Tie Rod*

- Traditional tie rod tube keeps wheel ends in alignment, extending tire life.

#### *Forged one-piece steer knuckles*

- Industry standard wheel end parts for simple replacement.

#### *Wheel Ends*

- 6-stud hub to accommodate 17.5" wheel and tire.



#### **Fully Cast Axle Ends**

Durable design adds strength to the critical axle transition area.

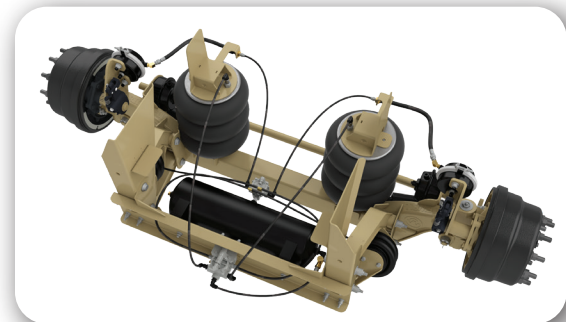

#### **Optional Pre-plumbed Air Tank**

Simplifies and decreases installation time. Complies with RMVSS121 Brake Requirements



#### **HUCKBOLTS®**

BobTail® HUCKBOLTS® provide superior joint integrity and 10x the fatigue strength over conventional bolts.

#### **Additional Features:**

- Kaiser™ kingpins available
- Suspension ships fully assembled
- 10.5" - 19.5" ride heights
- 31.2 degree wheel cut
- Offset control arms for improved lateral stability



**RIDEWELL**  
**SUSPENSIONS**

P.O. Box 4586 ♦ Springfield, Missouri 65808  
www.ridewellcorp.com ♦ 800.641.4122 ♦ Fax 417.833.4560