

Compact Mounting Envelope

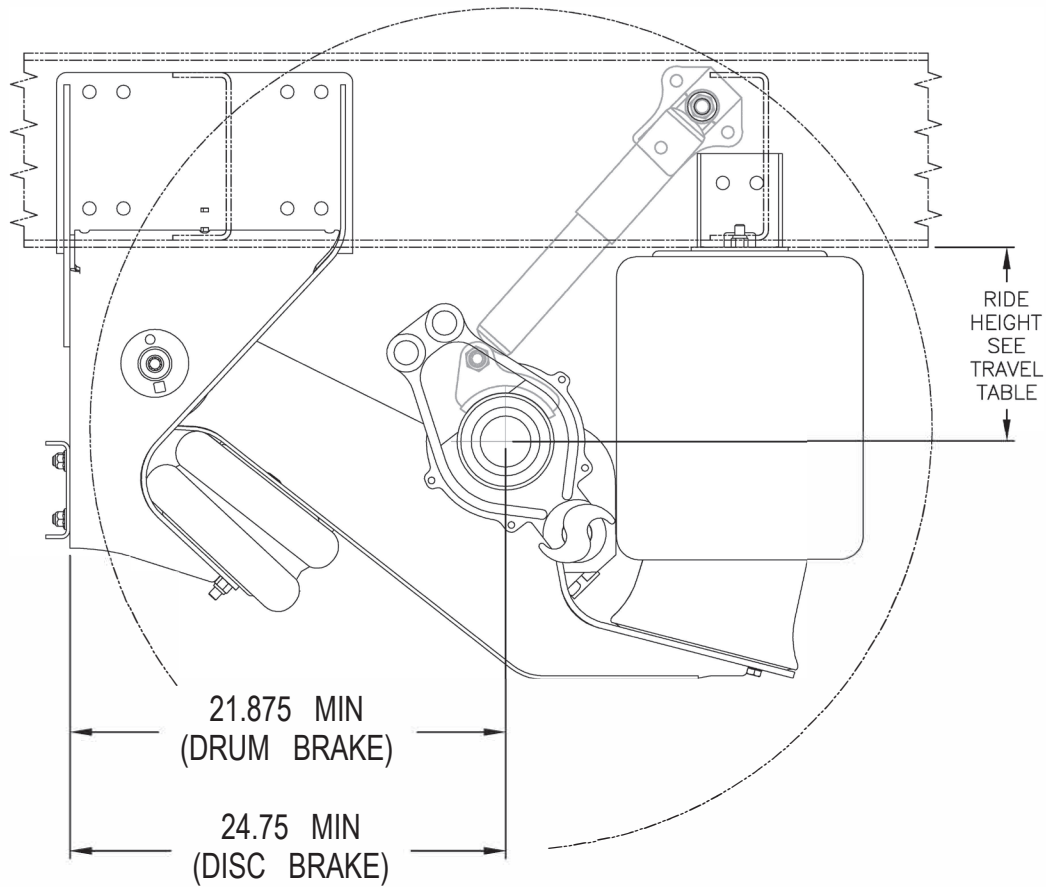

**RIDEWELL
SUSPENSIONS**

RCA-215 *Truck* Non-Steerable Auxiliary Axle Suspension



RCA-215
22,500 lb Capacity

TRAVEL TABLE 215 LM 2150202, 2150145							TRAVEL TABLE 215 MM 2150204, 2150147							TRAVEL TABLE 215 HM 2150205, 2150146						
RIDE HEIGHT	NO SPACER		1' SPACER		2' SPACER		RIDE HEIGHT	NO SPACER		1' SPACER		2' SPACER		RIDE HEIGHT	NO SPACER		1' SPACER		2' SPACER	
	UP	DOWN	UP	DOWN	UP	DOWN		UP	DOWN	UP	DOWN	UP	DOWN		UP	DOWN	UP	DOWN	UP	DOWN
7.50	4.5	5.8	—	—	—	—	9.50	4.5	5.8	—	—	—	—	11.50	4.5	5.8	—	—	—	—
8.00	5.0	5.3	—	—	—	—	10.00	5.0	5.3	—	—	—	—	12.00	5.0	5.3	—	—	—	—
8.50	5.5	4.8	4.5	5.8	—	—	10.50	5.5	4.8	4.5	5.8	—	—	12.50	5.5	4.8	4.5	5.8	—	—
9.00	6.0	4.3	5.0	5.3	—	—	11.00	6.0	4.3	5.0	5.3	—	—	13.00	6.0	4.3	5.0	5.3	—	—
9.50	6.5	3.8	5.5	4.8	4.5	5.8	11.50	6.5	3.8	5.5	4.8	4.5	5.8	13.50	6.5	3.8	5.5	4.8	4.5	5.8
10.00	7.0	3.3	6.0	4.3	5.0	5.3	12.00	7.0	3.3	6.0	4.3	5.0	5.3	14.00	7.0	3.3	6.0	4.3	5.0	5.3
10.50	—	—	6.5	3.8	5.5	4.8	12.50	—	—	6.5	3.8	5.5	4.8	14.50	—	—	6.5	3.8	5.5	4.8
11.00	—	—	7.0	3.3	6.0	4.3	13.00	—	—	7.0	3.3	6.0	4.3	15.00	—	—	7.0	3.3	6.0	4.3
11.50	—	—	—	—	6.5	3.8	13.50	—	—	—	—	6.5	3.8	15.50	—	—	—	—	6.5	3.8
12.00	—	—	—	—	7.0	3.3	14.00	—	—	—	—	7.0	3.3	16.00	—	—	—	—	7.0	3.3

Durable, lightweight bushing

Easily adjusts to various frame widths & ride heights

Easy axle alignment system

Axle integration available

Disc brake available



RCA-215 Non-Steerable Auxiliary Axle Suspension

Shear-Type Pivot Bolt

Simple to install, this high strength fastener automatically applies the required clamping force - no torque wrench or re-torque required.



SpeedSet® Axle Alignment System

This simple alignment feature is quick and easy. Axle alignment adjustment capability +/- .25" at hanger.

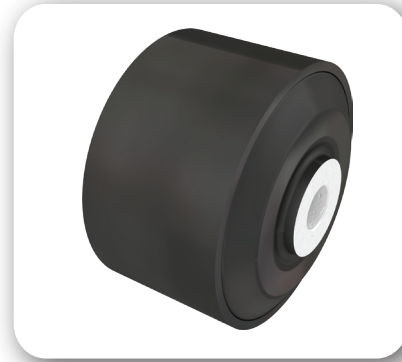

Premium Rubber Bushing

Superior performance at the critical pivot connection with our solid rubber narrow bushing.



Shock Kit

This optional shock kit provides added stability. Recommended when air equalization is intended between auxiliary and primary suspensions.



Disc Brakes

This option provides reduced stopping distance and maintenance.

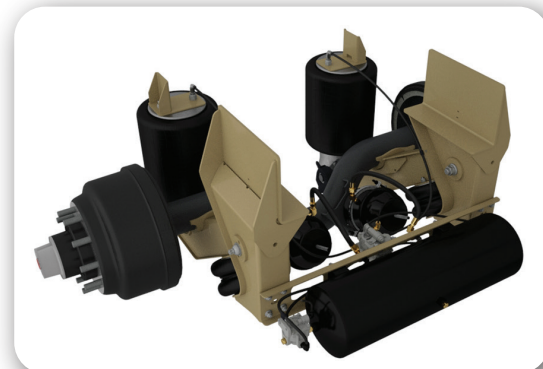

Optional Pre-Plumbed Air Tank

Simplifies and decreases installation time.

Additional Features

Wide beam spacing reduces axle stress
Fits ride heights 7.5 - 16"
10.5" total travel; up to 7"
215 LKS steerable version available
Accepts Drop axle up to 8"