

Compact Mounting Envelope

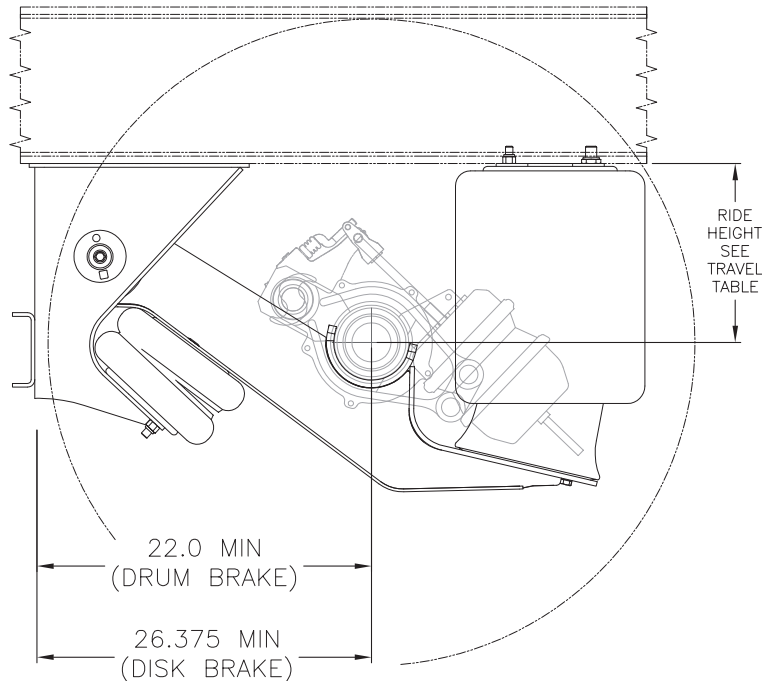

**RIDEWELL
SUSPENSIONS**

RCA-215T Trailer Non-Steerable Auxiliary Axle Suspension

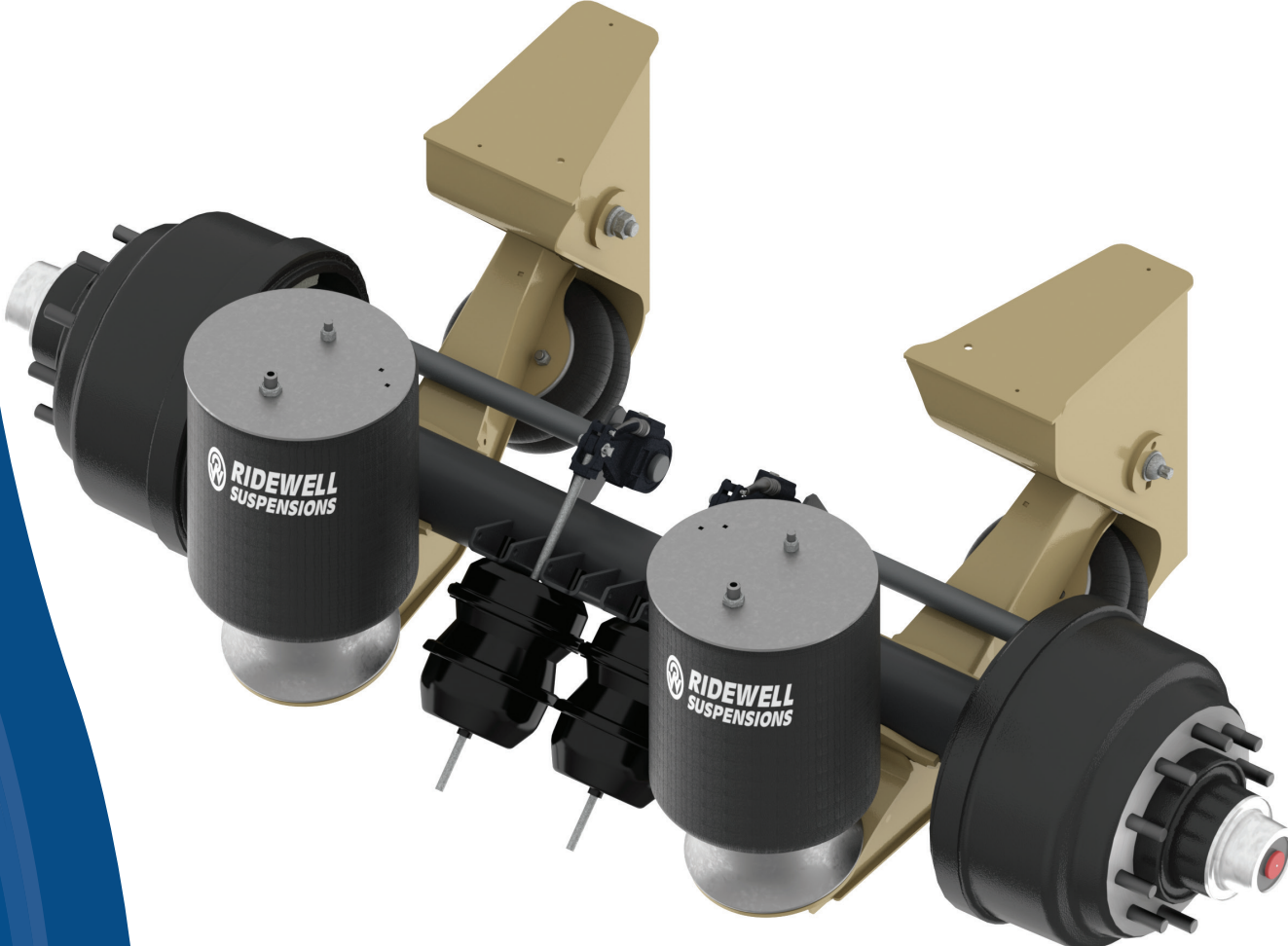

RCA-215T
22,500 lb Capacity

<i>TRAVEL TABLE 215 LMT 2150311, 2150148</i>			<i>TRAVEL TABLE 215 MMT 2150321, 2150150</i>			<i>TRAVEL TABLE 215 HMT 2150331, 2150149</i>		
RIDE HEIGHT	UP TRAVEL	DOWN TRAVEL	RIDE HEIGHT	UP TRAVEL	DOWN TRAVEL	RIDE HEIGHT	UP TRAVEL	DOWN TRAVEL
10.0"	4.8"	5.5"	12.0"	4.8"	5.5"	14.0"	4.8"	5.5"
10.5"	5.3"	5.0"	12.5"	5.3"	5.0"	14.5"	5.3"	5.0"
11.0"	5.8"	4.5"	13.0"	5.8"	4.5"	15.0"	5.8"	4.5"
11.5"	6.3"	4.0"	13.5"	6.3"	4.0"	15.5"	6.3"	4.0"
12.0"	6.8"	3.5"	14.0"	6.8"	3.5"	16.0"	6.8"	3.5"

- Durable, lightweight bushing*
- Easily adjusts to various frame widths and ride heights*
- Easy axle alignment system*
- Axle integration available*
- Disc brake option*



RCA-215T Non-Steerable Auxiliary Axle Suspension

Shear-Type Pivot Bolt

Simple to install, this high strength fastener automatically applies the required clamping force - no torque wrench or re-torque required.

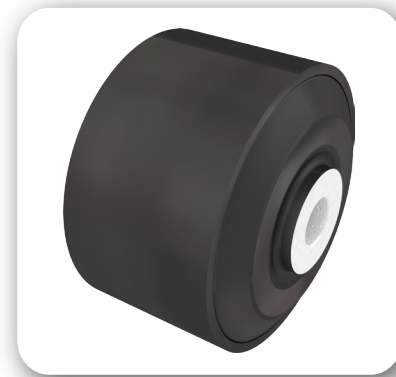
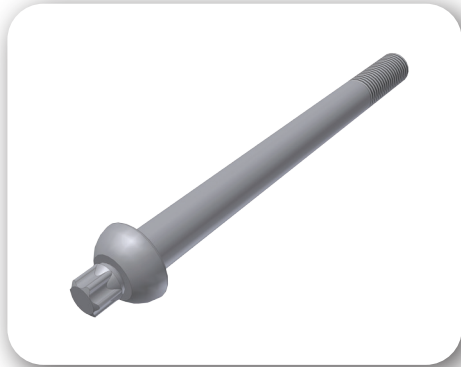

Premium Rubber Bushing

Superior performance at the critical pivot connection with our solid rubber narrow bushing.



Shock Kit

This optional shock kit provides added stability. Recommended when air equalization is intended between auxiliary and primary suspensions.



Disc Brakes

This option provides reduced stopping distance and maintenance.

SpeedSet® Axle Alignment System

This simple alignment feature is quick and easy. Axle alignment adjustment capability +/- .25" at hanger.

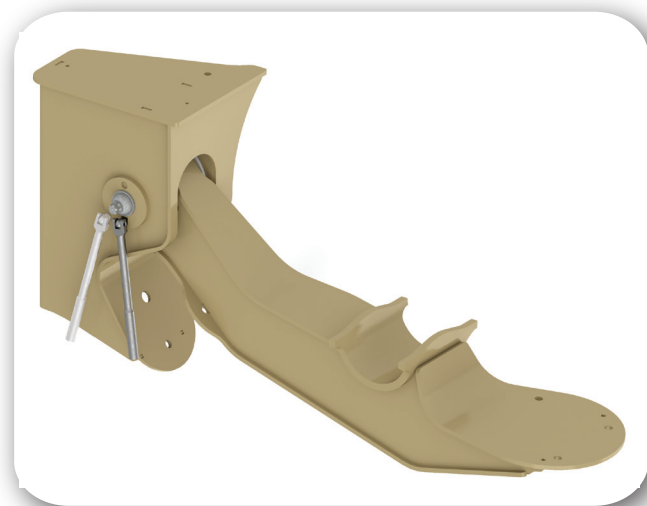

Additional Features

Wide beam spacing reduces axle stress
Fits ride heights 7.5 - 18"
10.5" total travel, up to 6.8" of lift