

Compact Mounting Envelope

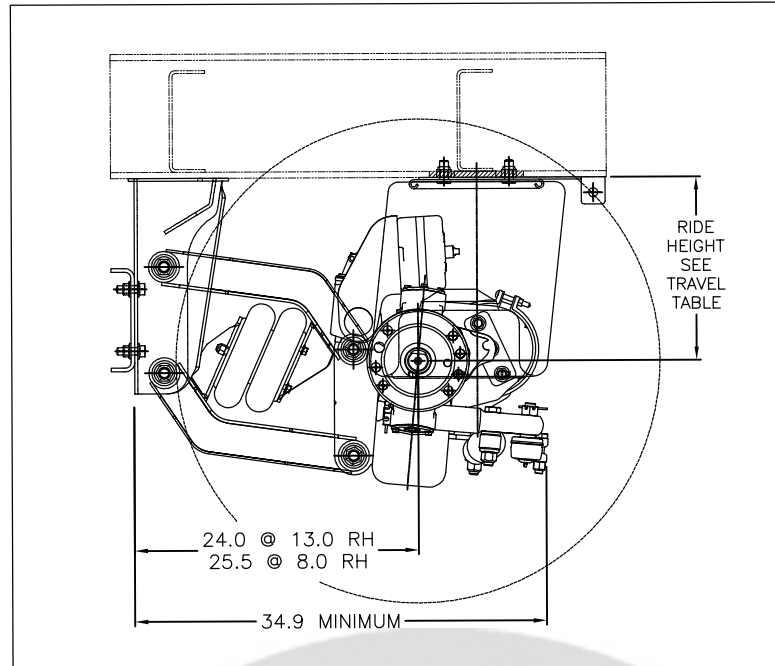

| TRAVEL TABLE 233 20K XLMT | | | TRAVEL TABLE 233 20K LMT | | |
|------------------------------|-----------|-------------|-----------------------------|-----------|-------------|
| RIDE HEIGHT | UP TRAVEL | DOWN TRAVEL | RIDE HEIGHT | UP TRAVEL | DOWN TRAVEL |
| 8.00" | 4.5" | 8.0" | 11.0" | 5.0" | 7.5" |
| 8.50" | 5.0" | 7.5" | 11.5" | 5.5" | 7.0" |
| 9.00" | 5.5" | 7.0" | 12.0" | 6.0" | 6.5" |
| 9.50" | 6.0" | 6.5" | 12.5" | 6.5" | 6.0" |
| 10.00" | 6.5" | 6.0" | 13.0" | 7.0" | 5.5" |
| 10.50" | 7.0" | 5.5" | 13.5" | 7.5" | 5.0" |
| 11.00" | 7.5" | 5.0" | 14.0" | 8.0" | 4.5" |
| 11.50" | 8.0" | 4.5" | 14.5" | 8.5" | 4.0" |
| 12.00" | 8.5" | 4.0" | 15.0" | 9.0" | 3.5" |
| 12.50" | 9.0" | 3.5" | 15.5" | 9.5" | 3.0" |
| 13.00" | 9.5" | 3.0" | | | |

| TRAVEL TABLE 233 20K MMT | | | TRAVEL TABLE 233 20K HMT | | |
|-----------------------------|-----------|-------------|-----------------------------|-----------|-------------|
| RIDE HEIGHT | UP TRAVEL | DOWN TRAVEL | RIDE HEIGHT | UP TRAVEL | DOWN TRAVEL |
| 13.5" | 5.0" | 7.5" | 16.0" | 5.0" | 7.5" |
| 14.0" | 5.5" | 7.0" | 16.5" | 5.5" | 7.0" |
| 14.5" | 6.0" | 6.5" | 17.0" | 6.0" | 6.5" |
| 15.0" | 6.5" | 6.0" | 17.5" | 6.5" | 6.0" |
| 15.5" | 7.0" | 5.5" | 18.0" | 7.0" | 5.5" |
| 16.0" | 7.5" | 5.0" | 18.5" | 7.5" | 5.0" |
| 16.5" | 8.0" | 4.5" | 19.0" | 8.0" | 4.5" |
| 17.0" | 8.5" | 4.0" | 19.5" | 8.5" | 4.0" |
| 17.5" | 9.0" | 3.5" | 20.0" | 9.0" | 3.5" |
| 18.0" | 9.5" | 3.0" | 20.5" | 9.5" | 3.0" |

**RIDEWELL
SUSPENSIONS**

RSS-233T 20K Trailer

Self-Steering Auxiliary Axle Suspension

Lightweight Without Sacrificing Durability

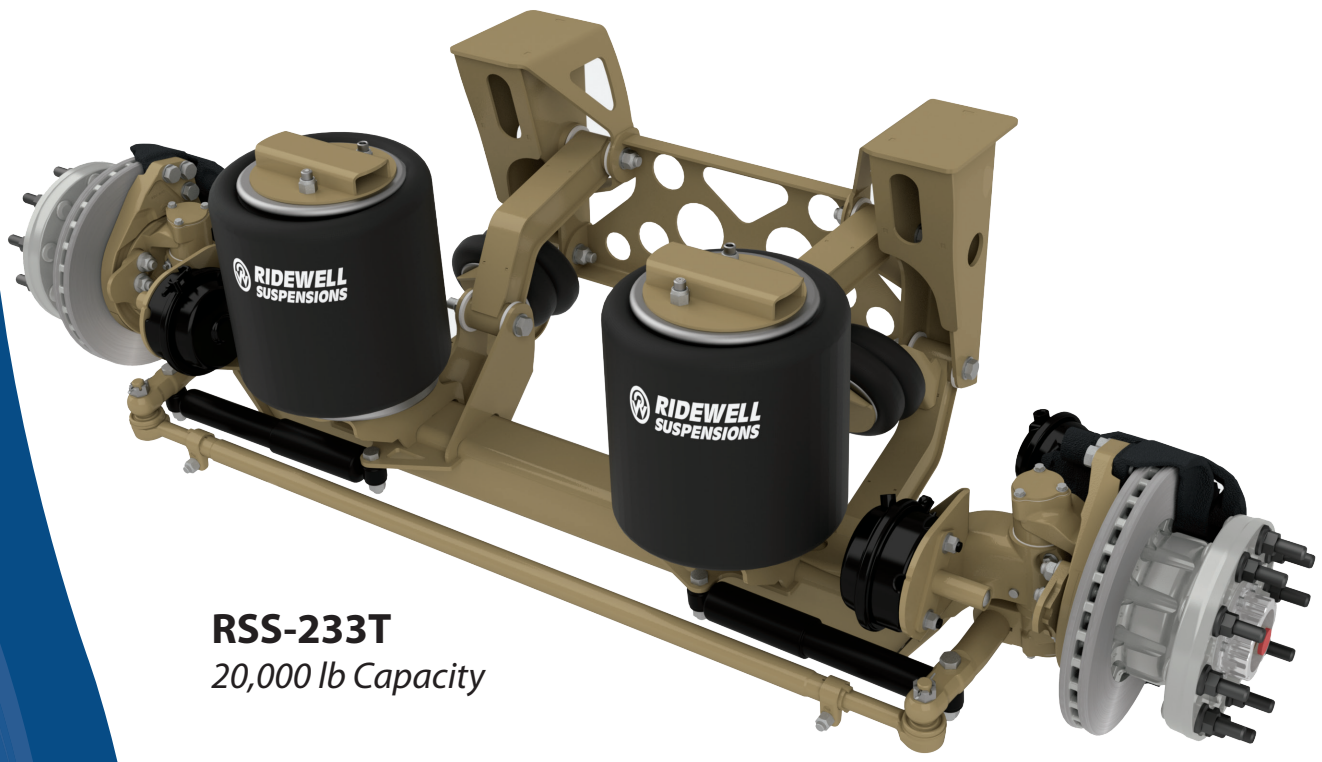

RSS-233T
20,000 lb Capacity

12.5' total travel, maximum of 9.5" lift

26 degree wheel cut

8" - 20.5" ride height range

Best in class mounting envelope

Kaiser™ kingpin option

Suspension ships fully assembled

Offset control arms for improved lateral stability

Industry standard tie rod

Forged one-piece steer knuckles



RSS-233T 20K Auxiliary Steerable Lift Axle

Dual Draw Kingpin Design

Design fully captures the kingpin within the axle end for longer service life and less down time.

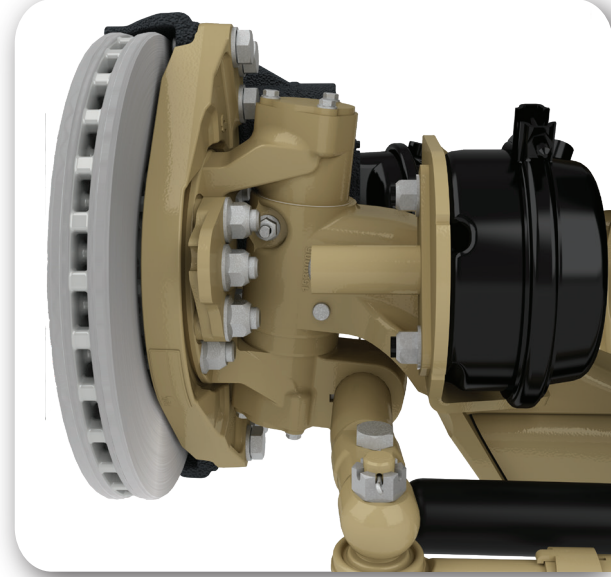

Steer Knuckles

Forged one-piece steer knuckles. Industry standard wheel end parts for simple replacement.

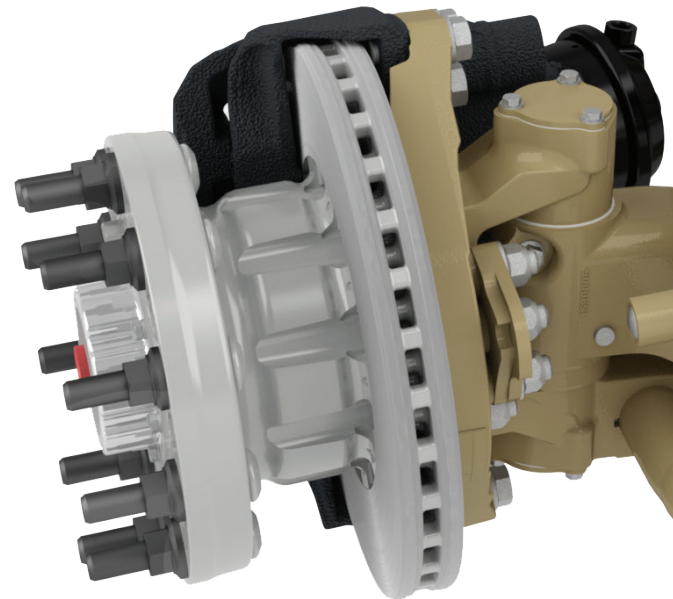

Additional Features:

- Axle track available in 90" & 96"
- SPIF compliant
 - Saves 337 lbs. per axle on quad and five axle trailers
- Spring, disc and drum brake options
- Bolt on option for aluminum frames

Optional Pre-plumbed Air Tank

Simplifies and decreases installation time.

*Complies with FMVSS121 Brake requirements.
Truck version shown.*

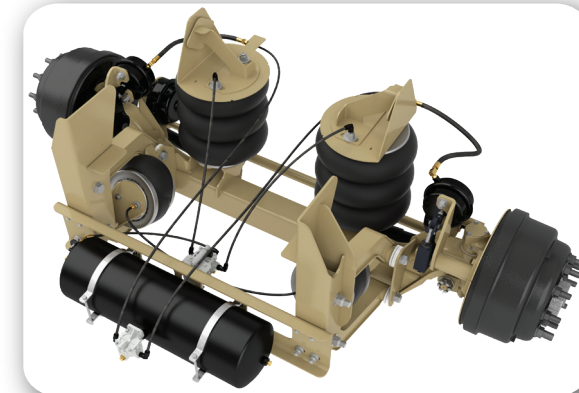

Optional Steer Locks

Unique design positively locks both wheel ends in the straight position. Can be activated at any wheel angle position.



Industry Standard Tie Rod

Traditional tie rod tube keeps wheel ends in alignment, extending tire life.

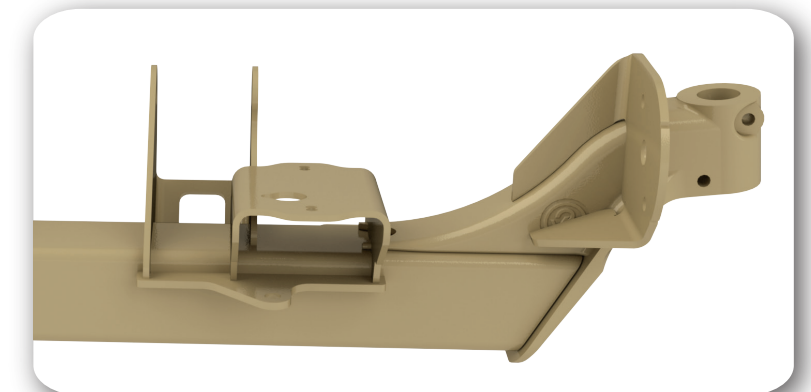

Fully Cast Axle Ends

Durable design adds strength to the critical axle transition area.