



Serving the Transportation Industry
Since 1967

**New Product Release
For Immediate Release
March 16, 2006**

Ridewell's Introduces New Flex-Trac™ in 8,000 lb capacity version

Ridewell Suspensions is pleased to introduce its new 8,000 lb capacity version of its Flex-Trac™, a self-steering, liftable auxiliary axle suspension system. The 8K Flex-Trac™ is the perfect suspension for when a bit more capacity is needed or when configuring a multiple axle truck to take maximum advantage of weight laws.

Ridewell's 8K Flex-Trac™ has all the features of the original Flex-Trac™ and weighs in at 690 lbs. Features include:

- A compact mounting envelope as low as 21.7" from the center of the spindle to the leading edge of the hanger;
- A one-size-fits-all system that easily adjusts to various frame widths and ride heights with no additional brackets required;
- 10" of up travel that can easily be optimized for various ride heights and 13 1/2" of total travel;
- Urethane bushings for long life;
- High tensile steel construction; and
- 28 degrees of wheel cut.

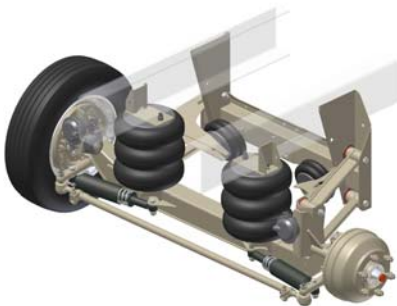

RSS-232-8K

Ridewell will introduce the 8K Flex-Trac™ at the Mid-America Trucking Show in Louisville, KY March 23-25, 2006.

For more information contact Ridewell Corporation, P.O. Box 4586, Springfield, MO 65808. Ph: 800-641-4122, (417) 833-4565, Fax: (417) 833-4560, www.ridewellcorp.com.

Media contact: Kristin Persson, 800-641-4122, ext. 136, kristinp@ridewellcorp.com